

MPC3-201

3-Series® Media Presentation Controller 201

The Crestron® MPC3-201 is a wall-mounted, PoE (Power over Ethernet) powered 3-Series® automated processor and control panel all in one. The MPC3-201 offers fully-programmable functionality, supports configuration and management via web or cloud-based interfaces, and integrates with Crestron Fusion® software as part of a complete managed enterprise solution.

Check the Box

Item	Qty
MPC3-201-B	1
Bit, Torx®, T8, Security (P/N 2025915)	1
Cable, Grounding (P/N 4509212)	1
Icon Chips, 30 Piece Set (P/N 4526558)	1
Screw, 4-40 x 3/16 in., Flat Head, Torx®, Black (P/N 2032041)	1
Screw, 4-40 x 1/4 in., Undercut Head, Phillips, Black (P/N 2007152)	5
Screw, 4B x 3/4 in., Flat Head, Phillips (P/N 2019088)	2
Screw, 6-32 x 1/4 in., Pan Head, SEMs (P/N 2007214)	1

Attach the Mounting Plate

The MPC3-201 is designed to install into a 1-gang European electrical box.

NOTE: The MPC3-101/102/201-RMB retrofit mounting bracket is also available to allow installation over a 2-gang U.S. electrical box for replacing an older MPC-M5 series controller. For more information, refer to the MPC3-101/102/201-RMB Quick Start (Doc. 8316) at www.crestron.com/manuals.

Use the two included 4B x 3/4 in. screws to attach the MPC3-201 mounting plate to the electrical box.

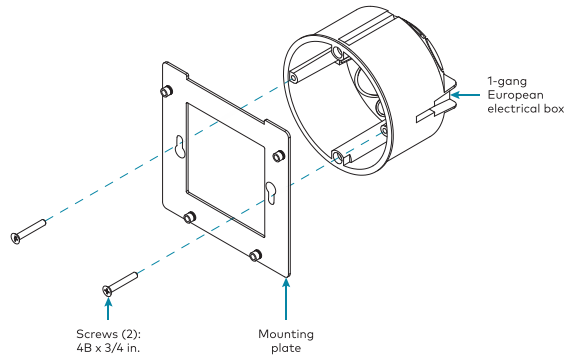

Connect the Device

Route all necessary cables through the rear of the electrical box, and then make connections to the MPC3-201 as shown in the following illustrations.

NOTE: Make all cable connections prior to attaching the MPC3-201 assembly to the electrical box.

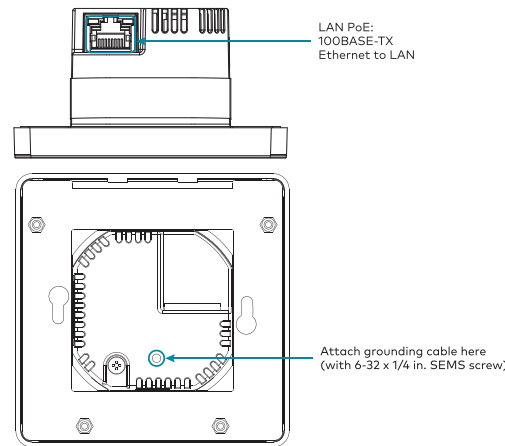

Observe the following when making connections to the MPC3-201:

- Use Crestron power supplies for Crestron equipment.
- A single Ethernet cable provides power and data to the MPC3-201. A Crestron PoE power supply, such as the PWE-4803RU, or a PoE-capable network switch is recommended (both sold separately).
- Ensure that the MPC3-201 is grounded properly. Insert the 6-32 x 1/4 in. SEMS screw through the terminal ring end of the included grounded cable, and then attach the screw to the hole in the rear of the assembly as shown in the illustration above. Then, attach the other end of the cable to a known earth ground (such as building steel).
- Apply power to the MPC3-201 after all connections have been made.

Install the Device

To install the MPC3-201:

1. Once all cable connections have been made, use four of the included 4-40 x 1/4 in. Phillips screws to attach the MPC3-201 assembly to the mounting plate.

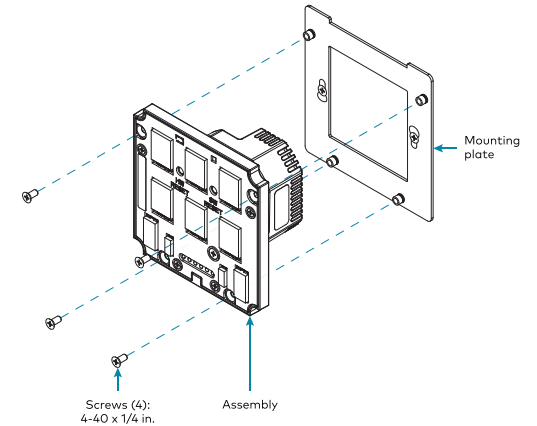

2. Punch out the desired icon chips from the icon packaging sheet.
3. Insert the chips, bottom side first, into the appropriate icon chip holders on the rear of the assembly. Ensure that each chip is oriented so that its icon label is facing forward.

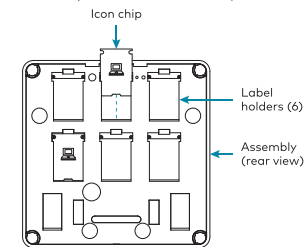

NOTES:

- Optional custom-engraved icon chips may be designed and ordered separately using Crestron Engraver software. To download the latest software version, navigate to <https://www.crestron.com/en-US/Software-Firmware/Software/Engraver/Crestron-Engraver/5-4-26-16>.
- To remove an icon chip from its holder, carefully pull the top of the chip away from the assembly so that it can be grasped, and then pull the chip upward and out of the holder.



4. Hold the magnetic bezel over the assembly.
5. Attach the bezel to the assembly, top side first, until the bezel magnetically snaps into place against the assembly.

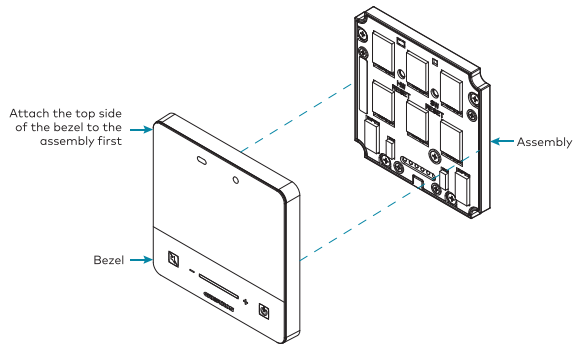

NOTE: If the bezel is removed and then reattached to the assembly, there is a 20-second delay before the buttons are functional.

6. (Optional) For a secure installation, screw either the remaining 4-40 x 1/4 in. Phillips screw or the Torx security screw into the screw hole on the bottom of the bezel to secure the bezel to the assembly.

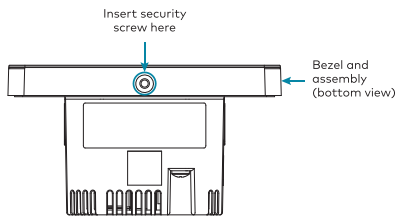

Configure the Device

The MPC3-201 may be configured using Crestron Toolbox™ software and the included web-based configuration utility.

To configure the MPC3 device:

1. Use the Device Discovery tool in Crestron Toolbox to discover the MPC3-201 and its IP address on the network.
2. Use Crestron Toolbox to set the time zone. For more information, refer to the Crestron Toolbox help file.
3. Use a web browser to navigate to <http://xxx.xxx.xxx.xxx/setup>, where xxx.xxx.xxx.xxx is the IP address of the MPC3-201. The 3-Series splash screen is displayed.



NOTE: If a security warning is displayed, click **Install** to continue.

4. Click **Setup**. The MPC3-201 Setup page is displayed.

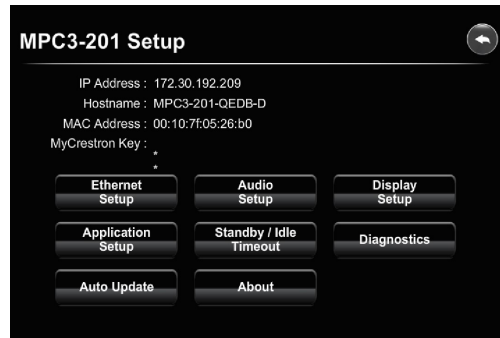

The MPC3-201 Setup page displays the IP address, hostname, and MAC address of the MPC3-201, as well as a key that is used to register the MPC3-201 with the MyCrestron service.

The Setup page also provides access to various setup and programming screens.

- Click one of the setup selections to configure the applicable device settings.
- Click the back button on any page to return to the previous screen.

Program the Device

Use the Device Discovery tool in Crestron Toolbox to discover the MPC3-201 and its IP address on the network, and then perform any necessary programming via TCP/IP over an Ethernet connection. For more information on device discovery and programming, refer to the appropriate sections of the embedded Crestron Toolbox help file.

NOTE: Any press-and-hold functionality for device buttons must be programmed to less than 20 seconds.

Connect to Crestron XiO Cloud™ Service (Optional)

The Crestron XiO Cloud™ service allows supported Crestron devices across an enterprise to be managed and configured from one central and secure location in the cloud. Supported devices are configured to connect to the service. Use of the service requires a registered Crestron XiO Cloud account.

NOTE: The device may be disconnected from the service by navigating to the Cloud Services tab in Crestron Toolbox software (**Functions > Device Info > Cloud Services**). For details, refer to the Crestron Toolbox help file.

To connect the device to the Crestron XiO Cloud service:

1. Record the MAC address and serial number that are labeled on the shipping box or rear panel of the device. The MAC address and serial number are required to add the device to the Crestron XiO Cloud environment.
2. Enter the device IP address into a web browser to access the web configuration interface.
3. Click the **Settings** tab.
4. Click **Cloud Settings** to expand the selection.
5. Toggle the **Cloud Configuration Service Connection** switch to **Enabled**.
6. Do either of the following:
 - For existing accounts, navigate to <https://portal.crestron.io>.
 - For new accounts, register for an account at www.crestron.com/xio-cloud-registration.

For Additional Information

Scan or click the QR code for detailed product information.



Compliance and Legal

Original Instructions: The U.S. English version of this document is the original instructions. All other languages are a translation of the original instructions.

Regulatory Model: M201902002

As of the date of manufacture, the product has been tested and found to comply with specifications for CE marking.



This product is listed to applicable UL® Standards and requirements tested by Intertek® service.

Ce produit est homologué selon les normes et les exigences UL applicables par service Intertek.



Federal Communications Commission (FCC) Compliance Statement

This device complies with part 15 of the FCC Rules. Operation is subject to the following conditions: (1) This device may not cause harmful interference and (2) this device must accept any interference received, including interference that may cause undesired operation.

CAUTION: Changes or modifications not expressly approved by the manufacturer responsible for compliance could void the user's authority to operate the equipment.

NOTE: This equipment has been tested and found to comply with the limits for a Class B digital device, pursuant to part 15 of the FCC Rules. These limits are designed to provide reasonable protection against harmful interference in a residential installation. This equipment generates, uses and can radiate radio frequency energy and, if not installed and used in accordance with the instructions, may cause harmful interference to radio communications. However, there is no guarantee that interference will not occur in a particular installation. If this equipment does cause harmful interference to radio or television reception, which can be determined by turning the equipment off and on, the user is encouraged to try to correct the interference by one or more of the following measures:

- Reorient or relocate the receiving antenna.
- Increase the separation between the equipment and receiver.
- Connect the equipment into an outlet on a circuit different from that to which the receiver is connected.
- Consult the dealer or an experienced radio/TV technician for help.

Industry Canada (IC) Compliance Statement

CAN ICES-3 (B)/NMB-3(B)

The product is a class 1 laser product. It complies with safety regulations of IEC 60825-1, FDA 21 CFR 1040.11 and FDA 21 CFR 1040.10.

WARNING: Visible and invisible laser radiation when open. Avoid direct exposure to beam.

Le produit est un produit laser de classe 1. Il est conforme aux normes de sécurité IEC-60825-1, FDA 21 CFR 1040.11 et FDA 21 CFR 1040.10.

AVERTISSEMENT: Rayonnement laser visible et invisible lorsqu'il est ouvert. Éviter l'exposition directe au faisceau.

Produkten är en laserprodukt av klass 1. Det uppfyller säkerhetsbestämmelserna i IEC-60825-1, FDA 21 CFR 1040.11 och FDA 21 CFR 1040.10.

WARNING: Synlig och osynlig laserstrålning vid öppning. Undvik direkt strålningsexponering.



Crestron product development software is licensed to Crestron dealers and Crestron Service Providers (CSPs) under a limited non-exclusive, non-transferable Software Development Tools License Agreement. Crestron product operating system software is licensed to Crestron dealers, CSPs, and end-users under a separate End-User License Agreement. Both of these Agreements can be found on the Crestron website at www.crestron.com/legal/software_license_agreement.

The product warranty can be found at www.crestron.com/warranty.

The specific patents that cover Crestron products are listed at www.crestron.com/legal/patents.

Certain Crestron products contain open source software. For specific information, please visit www.crestron.com/opensource.

Crestron, the Crestron logo, 3-Series, Cresnet, Crestron Fusion, Crestron Toolbox, Crestron XiO Cloud, and the MPC logo are either trademarks or registered trademarks of Crestron Electronics, Inc. in the United States and/or other countries. Torx is either a trademark or a registered trademark of Acument Intellectual Properties, LLC, in the United States and/or other countries. Intertek is either a trademark or registered trademark of Intertek Group in the United States and/or other countries. The ETL logo is either a trademark or registered trademark of Intertek Testing Services NA in the United States and/or other countries. UL is either a trademark or a registered trademark of Underwriters Laboratories, Inc. in the United States and/or other countries. Other trademarks, registered trademarks, and trade names may be used in this document to refer to either the entities claiming the marks and names or their products. Crestron disclaims any proprietary interest in the marks and names of others. Crestron is not responsible for errors in typography or photography.

©2019 Crestron Electronics, Inc

Crestron Electronics, Inc.
15 Volvo Drive, Rockleigh, NJ 07647
Tel: 988-CRESTRON
Fax: 201.767.7576
www.crestron.com

Quick Start - Doc. 87B6C
(2053540)
02.19

Specifications subject to change without notice.