

DM-MD8X8-CPU3, DM-MD16X16-CPU3, DM-MD32X32-CPU3, DM-MD8X8-CPU3-RPS, DM-MD16X16-CPU3-RPS, DM-MD32X32-CPU3-RPS
DigitalMedia™ Switchers

DO Install the Device

Crestron® DigitalMedia™ switchers can be mounted into a rack or placed onto a flat surface.

NOTE: Unless otherwise indicated, references to the DM-MD8X8-CPU3, DM-MD16X16-CPU3, and DM-MD32X32-CPU3 throughout this guide also apply to the DM-MD8X8-CPU3-RPS, DM-MD16X16-CPU3-RPS, and DM-MD32X32-CPU3-RPS, respectively.

Mount into a Rack

Refer to the following sections for information about mounting the DigitalMedia switchers into a rack.

DM-MD8X8-CPU3 and DM-MD16X16-CPU3 Rack Mounting

The DM-MD8X8-CPU3 occupies 4U of rack space. The DM-MD16X16-CPU3 occupies 7U of rack space. Using a #2 Phillips screwdriver (not included) and the included 6-32 x 3/8" Phillips screws, attach the two included rack ears to the device. Then, mount the device into the rack using four mounting screws (not included) for the DM-MD8X8-CPU3 or eight mounting screws (not included) for the DM-MD16X16-CPU3.

Attachment of Rack Ears (DM-MD8X8-CPU3 Shown)

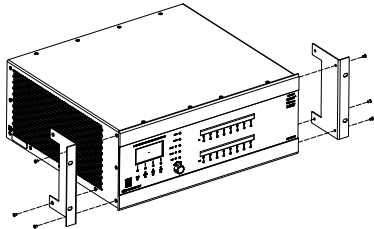

DM-MD32X32-CPU3 Rack Mounting

The DM-MD32X32-CPU3 occupies 14U of rack space. Rack ears are molded into the chassis and cannot be removed. Mount the device into the rack using eight mounting screws (not included).

Place onto a Flat Surface

When placing the device onto a flat surface or stacking it with other equipment, attach the included feet near the corner edges on the underside of the device.

DO Connect the DMC Cards

DMC cards consist of the DMC-CPU3 card and various input and output cards. The DMC-CPU3 card is included with the switchers. The input and output cards are sold separately and are installed at the factory prior to shipment of the switchers.

Connect the DMC-CPU3 Card

The following illustration provides information about connections to the DMC-CPU3 card.

DMC-CPU3 Card

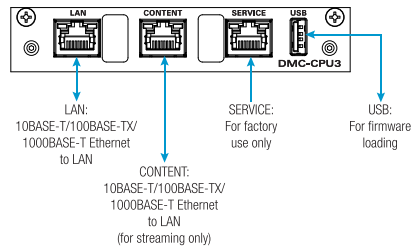

Connect Input Cards

The following illustrations provide information about connections to two of the available input cards: DMC-4KZ-C-DSP and DMC-4KZ-HD-DSP.

DMC-4KZ-C-DSP Input Card

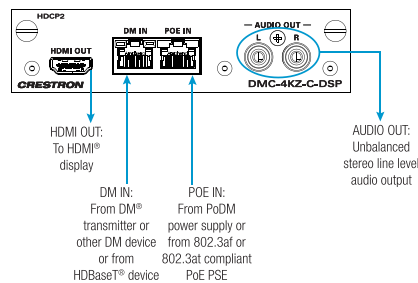

DO Check the Box

QUANTITY	ITEM	PART NUMBER
1	Cable, USB 2.0, A - B, 6' (1.83 m)	2014966
4	Foot, 0.5" x 0.5" x 0.23", Adhesive	2002389
DM-MD8X8-CPU3 and DM-MD8X8-CPU3-RPS Only		
2	Bracket, Rack Ear, 4U	2029093
1	Power Cord, 6' 7" (2 m)	4505164
6	Screw, 6-32 x 3/8", Undercut Head, Phillips	2007235
DM-MD16X16-CPU3 and DM-MD16X16-CPU3-RPS Only		
2	Bracket, Rack Ear, 7U	2023207
14	Screw, 6-32 x 3/8", Undercut Head, Phillips	2007235
DM-MD16X16-CPU3, DM-MD16X16-CPU3-RPS, DM-MD32X32-CPU3, and DM-MD32X32-CPU3-RPS Only		
1	Power Cord, 6' 6" (2 m)	4510874

DMC-4KZ-HD-DSP Input Card

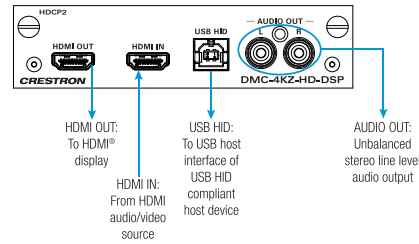

Connect Output Cards

The following illustrations provide information about connections to two of the available output cards: DMC-4KZ-CO-HD and DMC-4K-HDO.

DMC-4KZ-CO-HD Output Card

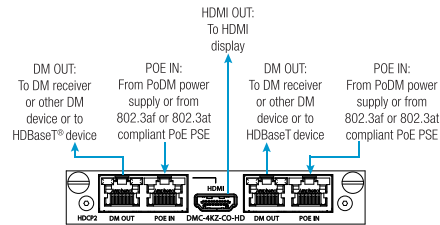

DMC-4K-HDO Output Card

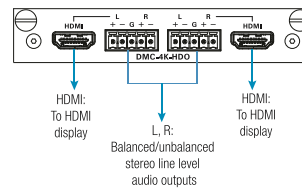

DO Power DM 8G+ Endpoints Using Power over DM

The DM IN port of a DM 8G+® input card and the DM OUT port of a DM 8G+ output card can power connected DM 8G+ endpoints using Power over DM (PoDM or PoDM+).

To enable the DM IN or DM OUT port to use PoDM or PoDM+:

- For PoDM, connect the corresponding POE IN port to a compatible PoDM or PoE power source. Compatible power sources (sold separately) include the Crestron DM-PSU-8, DM-PSU-16, DM-PSU-8-PLUS, DM-PSU-16-PLUS, DM-PSU-ULTRA-MIDSPAN, and CEN-SWPOE-16. Third-party 802.3af or 802.3at PoE Power Sourcing Equipment (PSE) can also be used. Refer to the connected DM 8G+ endpoint documentation for PoDM capabilities and requirements.
- For PoDM+, connect the corresponding POE IN port to a compatible PoDM+ or PoE+ power source. Compatible power sources (sold separately) include the Crestron DM-PSU-8-PLUS, DM-PSU-16-PLUS, DM-PSU-ULTRA-MIDSPAN, and CEN-SWPOE-16. Third-party 802.3at Type 2 Class 4 PoE+ PSE can also be used. Refer to the connected DM 8G+ endpoint documentation for PoDM+ capabilities and requirements.

Refer to the following illustration for an example of powering DM 8G+ devices using PoDM.

Powering DM 8G+ Devices Using PoDM

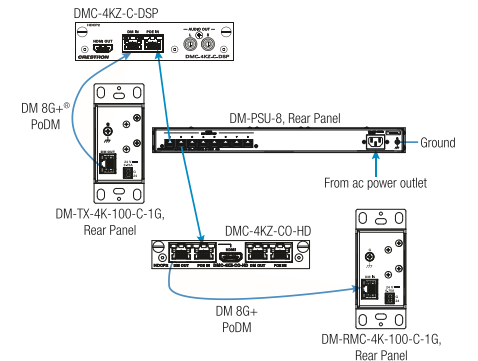

NOTES:

- The POE IN port does not provide a network connection. The port is only used to enable PoDM or PoDM+.
- The internal power supply of a DigitalMedia switcher does not power DM 8G+ endpoints.
- When PoDM or PoDM+ is used to power a DM 8G+ endpoint, connection of the endpoint to the included power pack is not required.
- Cabling that connects to a PoDM or PoE PSE port is designed for intrabuilding use only.

DO Route Inputs

Route inputs to one or more of the available outputs by using the front panel controls or the web interface.

Route Inputs Using the Front Panel Controls

To route inputs using the front panel controls:

- Press the **ROUTE** button. The AUDIO, VIDEO, and USB LEDs light, indicating the signal types that are to be routed. (Pressing the **AUDIO**, **VIDEO**, and **USB** buttons selects or deselects the corresponding signal type.)
- Press the appropriate **IN** button that corresponds to the input to be routed. The LED of the selected input lights. In addition, the LEDs of the outputs to which the input is currently routed also light.
- Press the appropriate **OUT** buttons that correspond to the desired outputs. The LEDs of the selected outputs flash to indicate that the input is not yet routed.
- Press the **ENTER** button to route the input. The LEDs of the selected outputs light steadily. The display shows the input number and the outputs to which the input is routed.

To disconnect an input from an output:

- Press the **ROUTE** button.
- Press the desired **OUT** button. The display shows **IN None**.
- Press the **ENTER** button. The output is disconnected from the input.

Route Inputs Using the Web Interface

To route inputs using the web interface:

- Find the IP address of the device by using the Device Discovery Tool in the Crestron Toolbox™ software.
- Open a web browser and go to the IP address.

- On the home page:
 - Click the input to be routed.
 - Click the desired outputs.
 - Click **Take**.

DO Configure the Device

Configure input, output, and network settings by using the front panel controls and Installer Tools or by using the web interface.

Configuration of network settings includes:

- IP address
- Subnet mask
- Default router
- DHCP
- Hostname
- Control system IP address

In addition, be aware of Private Network Mode (PNM). Using PNM, a DM® system uses only one IP address in the public network:

- PNM is enabled by default and cannot be disabled.
- In a DM system containing a single DM switcher, the DM switcher is the only DM device that uses an IP address in the public network. When DHCP is enabled, the IP address is set dynamically. When DHCP is disabled, the IP address must be set manually.
- All DMC I/O cards and DM endpoints (transmitters and receivers) connected to the DM switcher are hidden from the public network and cannot be reached directly. All communication is managed through the DM switcher. PNM creates a completely private IP network for all cards and endpoints.

NOTE: When a DM endpoint connects to a DM switcher, the convenience Ethernet port of the endpoint must not be connected to the LAN. A DM endpoint receives a network connection via the DM switcher. The convenience Ethernet port of a DM endpoint is available for connection to a network device such as a PC, Blu-ray™ player, or TV.

- When multiple DM switchers are cascaded:
 - Each DM switcher must connect directly to the LAN. A DM switcher cannot connect to the LAN through another DM switcher.
 - Each DM switcher must be assigned a unique system ID. PNM uses the system ID of each switcher to determine the internal IP address used by each device in the DM system. To assign a unique system ID, refer to the following section.

NOTE: This equipment has been tested and found to comply with the limits for a Class B digital device, pursuant to part 15 of the FCC Rules. These limits are designed to provide reasonable protection against harmful interference in a residential installation. This equipment generates, uses and can radiate radio frequency energy and, if not installed and used in accordance with the instructions, may cause harmful interference to radio communications. However, there is no guarantee that interference will not occur in a particular installation.

If this equipment does cause harmful interference to radio or television reception, which can be determined by turning the equipment off and on, the user is encouraged to try to correct the interference by one or more of the following measures:

- Reorient or relocate the receiving antenna.
- Increase the separation between the equipment and receiver.
- Connect the equipment into an outlet on a circuit different from that to which the receiver is connected.
- Consult the dealer or an experienced radio/TV technician for help.

Industry Canada (IC) Compliance Statement
CAN ICES-3(B)/NMB-3(B)

DO Assign a Unique System ID

When multiple DM switchers are cascaded, assign a unique system ID to each switcher by using the front panel controls and Installer Tools or by using the web interface. The system ID ranges from **1** to **64**. The default system ID is **1**.

NOTE: It is recommended that a number ranging from **2** to **64** be used. A system ID other than the default setting of **1** prevents potential conflicts when bringing additional switchers online.

Assign a Unique System ID Using the Front Panel Controls

To assign a unique system ID using the front panel controls:

- In Installer Tools, select **Network Setup**.

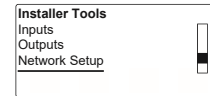

The Network Setup configuration screen appears.

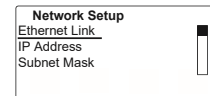

- Select **System ID**.

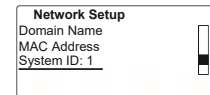

The Edit System ID configuration screen appears.

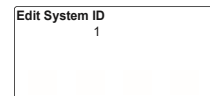

- Select a unique system ID for the DM switcher. The recommended setting ranges from **2** to **64**.
- Press the **MENU** button to exit Installer Tools.

Assign a Unique System ID Using the Web Interface

To assign a unique system ID using the web interface:

- Find the IP address of the device by using the Device Discovery Tool in the Crestron Toolbox software.
- Open a web browser and go to the IP address.
- On the Ethernet page, select a unique system ID for the DM switcher. The recommended setting ranges from **2** to **64**.

DO Connect to the Crestron XiO Cloud Service

The Crestron XiO Cloud® service allows supported Crestron devices across an enterprise to be managed and configured from one central and secure location in the cloud. Supported devices are preconfigured to connect to the service. Use of the service requires a registered Crestron XiO Cloud account.

To connect the device to the Crestron XiO Cloud service:

- Record the MAC1 address and the serial number that are labeled on the shipping box of the device. The MAC1 address, which is the MAC address of the LAN port on the DMC-CPU3 card, is also labeled on the faceplate of the card. The serial number is also labeled on the printed circuit board (PCB) of the DMC-CPU3 card. The MAC1 address and the serial number are required in order to add the device to the Crestron XiO Cloud environment.
- Do either of the following:
 - If you have a Crestron XiO Cloud account, go to <https://portal.crestron.io> to access the Crestron XiO Cloud service.
 - If you do not have a Crestron XiO Cloud account, go to www.crestron.com/xiocloud to register for an account.

For detailed information about using the Crestron XiO Cloud service, refer to the Crestron XiO Cloud Service User Guide (Doc. 8214) at www.crestron.com/manuals.

DO Learn More

Visit the website for additional information and the latest firmware updates.

Crestron Electronics
15 Volvo Drive, Rockleigh, NJ 07647
888.CRESTRON | www.crestron.com



CE As of the date of manufacture, the product has been tested and found to comply with specifications for CE marking.

UL This product is Listed to applicable UL® Standards and requirements tested by Underwriters Laboratories Inc.
Ce produit est homologué selon les normes et les exigences UL applicables par Underwriters Laboratories Inc.

Federal Communications Commission (FCC) Compliance Statement

This device complies with part 15 of the FCC Rules. Operation is subject to the following two conditions:

(1) This device may not cause harmful interference, and (2) this device must accept any interference received, including interference that may cause undesired operation.

CAUTION: Changes or modifications not expressly approved by the manufacturer responsible for compliance could void the user's authority to operate the equipment.



The DMC Fiber Series are class 1 laser products. They comply with safety regulations of IEC-60825-1, FDA 21 CFR 1040.11 and FDA 21 CFR 1040.10.

WARNING: Visible and invisible laser radiation when open. Avoid direct exposure to beam.

NOTE: Plug the included dust cap into the optical transceiver when the fiber optic cable is unplugged.

Rack Mounting Safety Precautions

- Elevated Operating Ambient Temperature:** If installed in a closed or multi-unit rack assembly, the operating ambient temperature of the rack environment may be greater than room ambient temperature. Therefore, consideration should be given to installing the equipment in an environment compatible with the maximum ambient temperature (T_{max}) specified by the manufacturer.
- Reduced Airflow:** Installation of the equipment in a rack should be such that the amount of airflow required for safe operation of the equipment is not compromised.
- Mechanical Loading:** Mounting of the equipment in the rack should be such that a hazardous condition is not achieved due to uneven mechanical loading.
- Circuit Overloading:** Consideration should be given to the connection of the equipment to the supply circuit and the effect that overloading of the circuits might have on overcurrent protection and supply wiring. Appropriate consideration of equipment nameplate ratings should be used when addressing this concern.
- Reliable Earthing:** Reliable earthing of rack-mounted equipment should be maintained. Particular attention should be given to supply connections other than direct connections to the branch circuit (e.g., use of power strips).

Electrical Connection
This product must be connected to an earthed mains socket-outlet.

- Finland: "Laitte on liitettävä suojaosadotuskoekentillä varustettuun pistorasiaan."
- Norway: "Apparøtet må tilkoples jordat stikkontakt."
- Sweden: "Apparøtet skall anslutas till jordat uttag."

The specific patents that cover Crestron products are listed at <http://www.crestron.com/legal/patents>.

The product warranty can be found at www.crestron.com/warranty.

Certain Crestron products contain open source software. For specific information, please visit www.crestron.com/opensource.

Manufactured under license under U.S. Patent Nos.: 5,958,674; 5,974,380; 6,226,616; 6,487,535; 7,212,872; 7,333,929; 7,392,195; 7,272,567 & other U.S. and worldwide patents issued & pending. DTS-HD, the Symbol, & DTS-HD and the Symbol together are registered trademarks of DTS, Inc. Product includes software. © DTS, Inc. All Rights Reserved.

Manufactured under license from Dolby Laboratories. Dolby and the double-D symbol are trademarks of Dolby Laboratories.

Crestron, the Crestron logo, Crestron Toolbox, Crestron XiO Cloud, DigitalMedia, DM, and DM 8G+ are either trademarks or registered trademarks of Crestron Electronics, Inc. in the United States and/or other countries. Blu-ray is either a trademark or registered trademark of the Blu-ray Disc Association in the United States and/or other countries. HDBaseL and the HDBaseL Alliance logo are either trademarks or registered trademarks of the HDBaseL Alliance in the United States and/or other countries. HDMI and the HDMI logo are either trademarks or registered trademarks of HDMI Licensing LLC in the United States and/or other countries. UL and the UL logo are either trademarks or registered trademarks of Underwriters Laboratories, Inc. in the United States and/or other countries. Other trademarks, registered trademarks, and trade names may be used in this document to refer to either the entities claiming the marks and names or their products. Crestron disclaims any proprietary interest in the marks and names of others. Crestron is not responsible for errors in typography or photography.

©2018 Crestron Electronics, Inc.