



AirMedia®  
Presentation Gateway

Deployment Guide  
Crestron Electronics, Inc.



Crestron Fusion®



Crestron product development software is licensed to Crestron dealers and Crestron Service Providers (CSPs) under a limited non-exclusive, non-transferable Software Development Tools License Agreement. Crestron product operating system software is licensed to Crestron dealers, CSPs, and end-users under a separate End-User License Agreement. Both of these Agreements can be found on the Crestron website at [www.crestron.com/legal/software\\_license\\_agreement](http://www.crestron.com/legal/software_license_agreement).

The product warranty can be found at [www.crestron.com/legal/sales-terms-conditions-warranties](http://www.crestron.com/legal/sales-terms-conditions-warranties).

The specific patents that cover Crestron products are listed at [www.crestron.com/legal/patents](http://www.crestron.com/legal/patents).

Certain Crestron products contain open source software. For specific information, visit [www.crestron.com/legal/open-source-software](http://www.crestron.com/legal/open-source-software).

Crestron, the Crestron logo, 3-Series, .AV Framework, AirMedia, Crestron Connected, Crestron Fusion, Crestron Mercury, Crestron Studio, DigitalMedia, DM, PinPoint, Crestron XiO Cloud, the Crestron XiO Cloud logo, and Zūm are either trademarks or registered trademarks of Crestron Electronics, Inc. in the United States and/or other countries. AirPlay, App Store, Bonjour, iCloud, iPad, iPhone, Mac, and macOS are either trademarks or registered trademarks of Apple, Inc. in the U.S. and/or other countries. IOS is either a trademark or registered trademark of Cisco Systems, Inc. in the United States and/or other countries. Dropbox is either a trademark or registered trademark of Dropbox Inc. in the United States and/or other countries. Android, Chromebook, Chrome OS, Google, Google Chrome, Google Drive, Google Play, and YouTube are either trademarks or registered trademarks of Google, Inc. in the United States and/or other countries. HDMI and the HDMI logo are either trademarks or registered trademarks of HDMI Licensing, LLC in the United States and/or other countries. Active Directory, Excel, Microsoft, OneDrive, PowerPoint, and Windows are either trademarks or registered trademarks of Microsoft Corporation in the United States and/or other countries. Miracast, Wi-Fi, and Wi-Fi Direct are either trademarks or registered trademarks of Wi-Fi Alliance in the United States and/or other countries. Other trademarks, registered trademarks, and trade names may be used in this document to refer to either the entities claiming the marks and names or their products. Crestron disclaims any proprietary interest in the marks and names of others. Crestron is not responsible for errors in typography or photography.

## HDMI

This document was written by the Technical Publications department at Crestron.  
©2019 Crestron Electronics, Inc.

# Contents

- Introduction ..... 1**
- Select the Right System..... 3**
  - AirMedia 2.0 Devices ..... 3
  - AirMedia Devices ..... 6
- AirMedia Network Infrastructure and Security..... 7**
  - AirMedia Bandwidth Requirements ..... 7
  - Network Infrastructure and Design Considerations ..... 8
  - Deployment Options for Guest Network Access ..... 10
    - VLAN..... 10
    - Physical Air Gap ..... 10
  - Data Transport & Encrypted Communications ..... 11
- AirMedia Device Considerations..... 12**
  - Device Naming..... 12
  - Device Configuration ..... 12
  - Firewall Settings & Port Table ..... 14
- Device Upgrades..... 17**
  - Single Device (Web Interface) ..... 17
  - Multiple Devices..... 17
- Control..... 17**
  - .AV Framework and Crestron XiO Cloud Service ..... 17
  - Crestron Connected ..... 18
  - Control System..... 18
- Deploy AirMedia Sender Applications to PCs..... 19**
  - Windows ..... 19
  - macOS..... 21
  - Configure Room Lists..... 22
    - Configuration File (config.ini) ..... 22
    - Room List (XML File) for Windows and macOS ..... 24
  - File Association for Windows and macOS ..... 24
  - Discovery ..... 25
  - Manual Entry ..... 25
  - Custom URI Protocol ..... 26
- Use AirMedia..... 26**
  - Welcome Screen ..... 26
  - Connection Experience..... 27
  - Login Code ..... 28

|  |           |
|--|-----------|
| PC Sender Applications .....   | 29        |
| User Experience with Windows .....   | 29        |
| User Experience with macOS .....   | 35        |
| User Experience with ChromeOS .....  | 40        |
| <b>Miracast on AirMedia 2.0 .....</b>  | <b>41</b> |
| Required Wireless Adaptor .....  | 41        |
| Miracast Behavior – How it Works .....   | 42        |
| Supported Miracast Devices .....   | 42        |
| Considerations for Deploying and Commissioning Miracast for AirMedia 2.0 Devices ..... | 42        |
| Troubleshooting Miracast Connection Issues .....                                       | 43        |
| <b>AirMedia Apps.....</b>  | <b>44</b> |
| AirMedia App for iOS Devices .....   | 44        |
| AirMedia for AM-100 App for iOS Devices .....  | 44        |
| AirMedia App for Android Devices .....   | 44        |
| AirMedia for AM-100 App for Android Devices .....                                      | 44        |
| Connect to AirMedia Devices with Mobile Applications .....                             | 45        |
| <b>Test and Commission the AirMedia Presentation System .....</b>                      | <b>48</b> |
| AirMedia Test Use Cases by User Experience .....                                       | 48        |
| Front of Room Experience .....   | 48        |
| PC User Experience Test Case Considerations .....                                      | 49        |
| Mobile User Experience Test Case Considerations .....                                  | 49        |
| Commission and Monitor AirMedia Devices .....  | 50        |

# Introduction

The Crestron® AirMedia Presentation Gateway family allows users to present content and collaborate on displays by leveraging existing IT infrastructure; without the necessity for wired connections or additional hardware. The latest AirMedia 2.0 devices - [AM-200](#), [AM-300](#), [DMPS3-4K-250-C](#), [DMPS3-4K-350-C](#), [DMPS3-4K-250-C-AIRMEDIA](#), [DMPS3-4K-350-C-AIRMEDIA](#), and [Crestron Mercury™](#) Presentation System (CCS-UC-1) – allow users to replicate their entire display wirelessly with the lowest latency and bandwidth consumption of any solution on the market. These AirMedia 2.0 devices complement the older, yet capable [AM-100](#) and [AM-101](#) AirMedia presentation gateways. All AirMedia devices are designed with the IT professional in mind, and include many features to ease deployment and management.

When connecting to AirMedia devices, there are no wires to connect, settings to configure, and no AV or control system is required. Users simply connect to the local Wi-Fi® network with a Windows®, macOS®, iOS® or Android™ device and the corresponding AirMedia application. Windows and macOS users can quickly download a sender application directly from the AirMedia device or have the application installed by IT administrators. Google® Chrome OS™ users can use the AirMedia extension to easily present web browser and desktop content. iOS and Android mobile devices can use the free apps available from the App Store® app on iOS and the Google Play™ app on Android. AirMedia 2.0 Presentation Gateways allow any device to share full-screen Excel® spreadsheets, Word documents, PowerPoint® presentations, PDF files, on-device videos, photos, and other content in meeting spaces easily and quickly.

For more information on specific AirMedia devices and their capabilities, please refer to the documents referenced below at [www.crestron.com/manuals](http://www.crestron.com/manuals).

- [AM-100 Operations Guide \(Doc 7463\)](#).
- [AM-101 Supplemental Guide \(Doc 7918\)](#).
- [AM-200/AM-300 Product Manual \(Doc. 8254\)](#).
- [Crestron® PinPoint™ App Deployment Guide \(Doc 7976\)](#).
- [CCS-UC-1 Supplemental Guide \(Doc 7844\)](#).
- [DMPS3-4K-200-C/DMPS3-4K-300-C Series Supplemental Guide \(Doc 7849C\)](#).

## DMPS3-4K-350-C Deployment Application

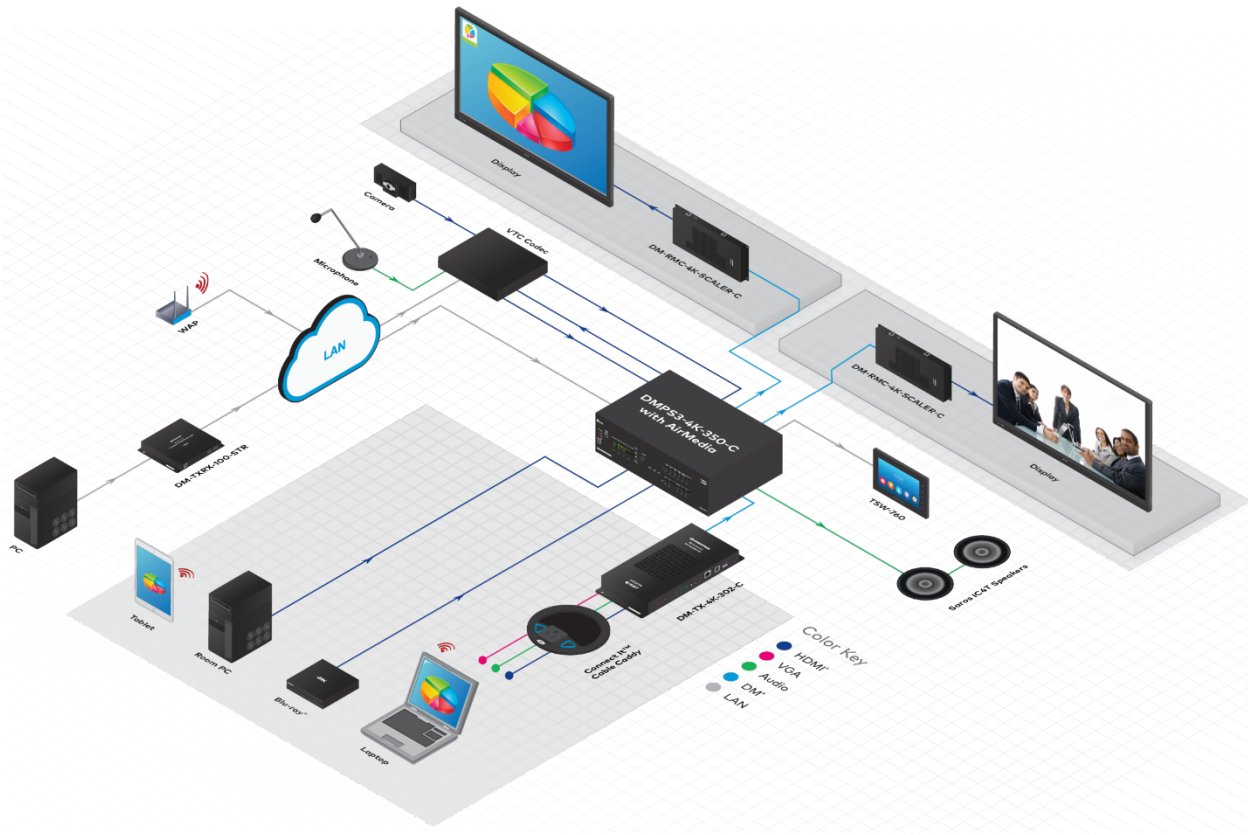

## AM-300 Deployment Application

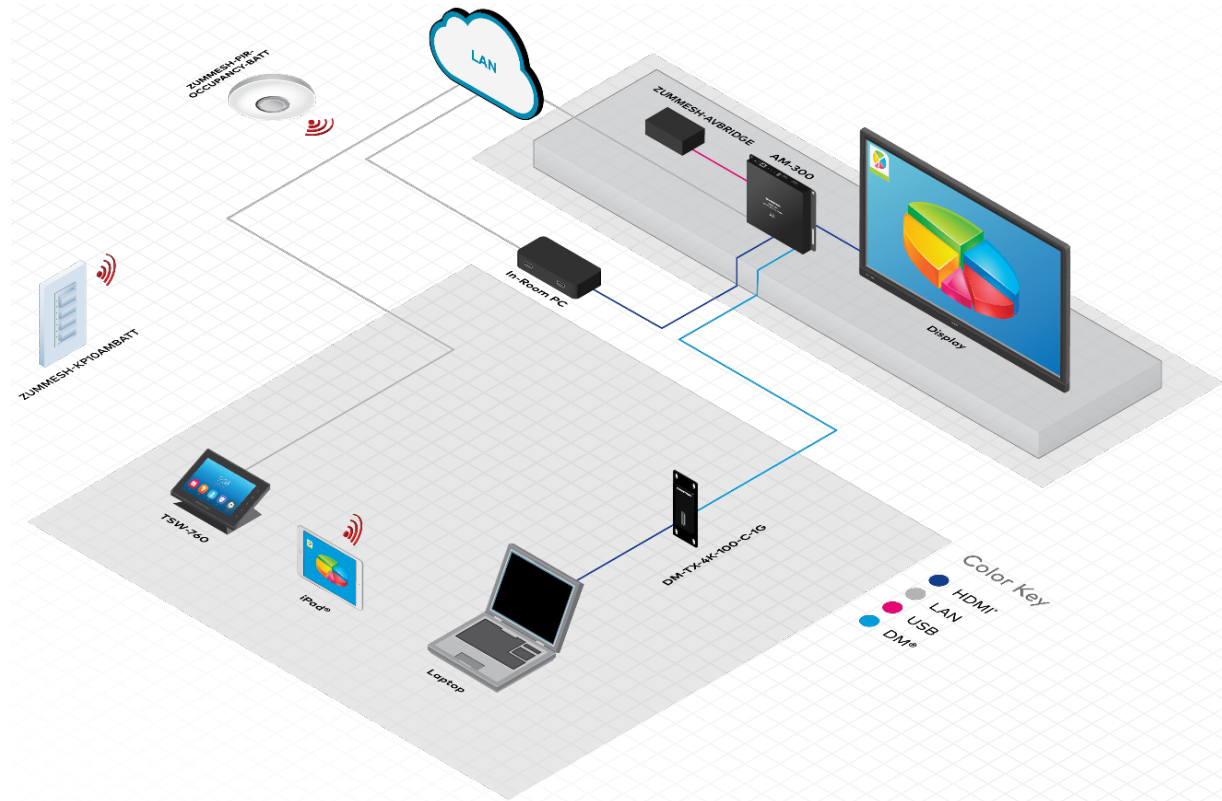

## Select the Right System

Crestron offers various models that meet a wide range of requirements. Refer to the following table to determine which model fits your application.

### AirMedia 2.0 Devices

| FEATURE                   | DETAIL                          | AM-200<br>AM-300 | DMPMS3-4K-250-C | DMPMS3-4K-350-C | CCS-UC-1 |
|---------------------------|---------------------------------|------------------|-----------------|-----------------|----------|
| Security                  | AES-128/TLS security            | ✓                | ✓               | ✓               | ✓        |
|                           | 802.1X                          | ✓                | ✓               | ✓               | ✓        |
|                           | Access Directory Authentication | ✓                | ✓               | ✓               | ✓        |
| Crestron Control Software | Crestron XiO Cloud™             | ✓                | ✓               | ✓               | ✓        |
|                           | .AV Framework™                  | ✓                | ✓               | ✓               | ✓        |
|                           | SIMPL Windows                   | ✓                | ✓               | ✓               | ✓        |
|                           | SIMPL # Pro                     | ✓                | ✓               | ✓               | ✓        |
|                           | Crestron Studio®                | -                | -               | -               | -        |
| AirMedia Device Support   | VC4                             | ✓                | ✓               | ✓               | ✓        |
|                           | PC-Windows All Versions         | ✓                | ✓               | ✓               | ✓        |
|                           | Mac®                            | ✓                | ✓               | ✓               | ✓        |
|                           | iPad®                           | ✓                | ✓               | ✓               | ✓        |
|                           | iPhone®                         | ✓                | ✓               | ✓               | ✓        |

| FEATURE                                    | DETAIL   | AM-200<br>AM-300            | DMPS3-4K-250-C | DMPS3-4K-350-C | CCS-UC-1 |
|--|--|-----------------------------|----------------|----------------|----------|
| AirMedia<br>Screen<br>Mirroring<br>Support | iOS  | ✓                           | ✓              | ✓              | ✓        |
|  | Android  | ✓                           | ✓              | ✓              | ✓        |
|  | PC-Windows All<br>Versions   | ✓                           | ✓              | ✓              | ✓        |
|  | Mac  | ✓                           | ✓              | ✓              | ✓        |
|  | iPad   | ✓                           | ✓              | ✓              | ✓        |
|  | iPhone   | ✓                           | ✓              | ✓              | ✓        |
|  | iOS  | ✓                           | ✓              | ✓              | ✓        |
|  | Android  | ✓                           | ✓              | ✓              | ✓        |
|  | Chromebook™<br>computer and<br>Chrome OS™<br>operating system <sup>1</sup>                     | ✓                           | Future         | Future         | ✓        |
| AirMedia<br>Video +<br>Audio<br>Playback   | PC-Windows All<br>Versions   | ✓                           | ✓              | ✓              | ✓        |
|  | Mac  | ✓                           | ✓              | ✓              | ✓        |
|  | iPad   | ✓                           | ✓              | ✓              | ✓        |
|  | iPhone   | ✓                           | ✓              | ✓              | ✓        |
|  | iOS  | ✓                           | ✓              | ✓              | ✓        |
|  | Android  | ✗                           | ✗              | ✗              | ✗        |
|  | Chromebook and<br>Chrome OS<br>(Support with audio<br>is supported only for<br>the active tab) | ✓                           | Future         | Future         | ✓        |
| AirMedia<br>Protocol<br>Support            | Airplay®   | ✓                           | ✓              | ✓              | ✓        |
|  | Miracast®  | ✓                           | ✗              | ✗              | ✓        |
| Integrated<br>Technology                   | AirMedia 2.0<br>technology   | ✓                           | ✓              | ✓              | ✓        |
|  | .AV Framework™<br>Platform   | ✓                           | ✓              | ✓              | ✓        |
|  | Crestron XiO<br>Cloud™ Service<br>support  | ✓                           | ✓              | ✓              | ✓        |
| Video<br>Inputs                            | HDMI®  | 1                           | 6              | 6              | 1        |
|  | HDMI Resolution  | 1080p                       | 4k60@420       | 4k60@420       | 1080p    |
|  | HDMI HDCP  | HDCP 1.4                    | HDCP 2.2       | HDCP 2.2       | HDCP 1.4 |
|  | 4K DigitalMedia™   | 1<br>(AM-300 only)          | 1 (4K)         | 2 (4K)         | ✗        |
|  | 4K DM® Resolution  | 4k60 4:2:0<br>(AM-300 only) | 4k60@420       | 4k60@420       | ✗        |
|  | 4K DM HDCP   | HDCP 2.2<br>(AM-300 only)   | HDCP 2.2       | HDCP 2.2       | ✗        |

<sup>1</sup> The AirMedia Extension for Google Chrome relies on web technologies for screen sharing that are built into the web browser. Performance variations with motion video (quality and frame rate) may occur based upon the encoding capabilities of the Chrome OS device and the nature of the content being displayed (i.e., high motion video).

| FEATURE             | DETAIL                                       | AM-200<br>AM-300                     | DMPS3-4K-250-C            | DMPS3-4K-350-C            | CCS-UC-1    |
|---------------------|--|--------------------------------------|---------------------------|---------------------------|-------------|
| Video Outputs       | HDMI Output                                  | ✓                                    | ✓                         | ✓ (x2)                    | ✓           |
|                     | HDMI Resolution                              | AM-200: 1080p<br>AM-300: 4k30        | 4k60@420                  | 4k60@420                  | 1080p       |
|                     | HDMI HDCP                                    | AM-200: HDCP 1.4<br>AM-300: HDCP 2.2 | HDCP 2.2                  | HDCP 2.2                  | HDCP 1.4    |
| Other Interfaces    | IR   | ✓                                    | ✓                         | ✓                         | ✓           |
|                     | RS232  | ✓                                    | ✓                         | ✓                         | ✓           |
|                     | CEC  | ✓                                    | ✓                         | ✓                         | ✓           |
|                     | Power of Ethernet (PoE/PoE+)                 | AM-200: ✓<br>AM-300: ✗               | ✗                         | ✗                         | ✓ (PoE+) *1 |
|                     | Dual LAN                                     | ✗                                    | ✓                         | ✓                         | ✓           |
| UC Features         | Speakerphone                                 | ✗                                    | ✗                         | ✗                         | ✓           |
|                     | Bluetooth                                    | ✗                                    | ✗                         | ✗                         | ✓           |
|                     | Microphone                                   | ✗                                    | ✗                         | ✗                         | ✓           |
| Additional Features | Pinpoint UX                                  | ✓                                    | Limited                   | Limited                   | ✓           |
|                     | Appspace® Software <sup>1</sup>              | ✓                                    | Future                    | Future                    | ✓           |
|                     | Crestron Airboard™ whiteboard capture system | ✓                                    | Future                    | Future                    | ✓           |
|                     | Control system interface                     | ✓                                    | ✓                         | ✓                         | ✓           |
|                     | AM-101 Compatibility Mode                    | AM-200: ✓<br>AM-300: ✗               | ✗                         | ✗                         | ✗           |
|                     | AirMedia 2.0 Connection Experience           | ✓                                    | Future                    | Future                    | ✓           |
|                     | Touch Screen Support                         | External                             | External                  | External                  | Integrated  |
|                     | Zūm™ Sensors and/or Buttons                  | ✓                                    | ✓                         | ✓                         | ✓           |
|                     | YouTube® Push Mode Support                   | ✓                                    | ✓                         | ✓                         | ✓           |
|                     | Mounting                                     | Freestanding Surface Rack            | Freestanding Surface Rack | Freestanding Surface Rack | Tabletop    |

<sup>1</sup> For best practices when configuring the AM-200/300 for use with Appspace software, please visit <https://docs.appspace.com/appspace/7.0/device-administration/basic/configure-device-integrations/crestron-mercury/>

| FEATURE | DETAIL                    | AM-200<br>AM-300   | DMPS3-4K-250-C                      | DMPS3-4K-350-C                      | CCS-UC-1                           |
|---------|---------------------------|--|-------------------------------------|-------------------------------------|------------------------------------|
|         | Dimensions<br>(W x H x D) | AM-200:<br>7.40 in. x 6.42<br>in. x 1.35 in.<br>AM-300:<br>9.29 in. x 7.93<br>in. x 1.36 in. | 17.28 in. x 5.20 in.<br>x 15.75 in. | 17.28 in. x 5.20 in. x<br>15.75 in. | 8.92 in. x 4.11<br>in. x 12.74 in. |

## AirMedia Devices

| FEATURE                            | AM-100                         | AM-101                         |
|------------------------------------|--------------------------------|--------------------------------|
| AirMedia 2.0 technology            | x                              | x                              |
| .AV Framework Platform             | x                              | x                              |
| Crestron XiO Cloud Service support | x                              | x                              |
| HDMI Input                         | x                              | x                              |
| DigitalMedia Input                 | x                              | x                              |
| HDMI Output                        | 1                              | 1                              |
| DigitalMedia Output                | x                              | x                              |
| Dual Display Support               | x                              | x                              |
| Touch Screen Support               | Via programming only           | Via programming only           |
| Unified Communications             | x                              | x                              |
| Zūm Sensors and/or Buttons         | x                              | x                              |
| COM/IR Support                     | x                              | x                              |
| PoE                                | x                              | x                              |
| Pinpoint UX                        | x                              | x                              |
| Appspace                           | x                              | x                              |
| Crestron Airboard                  | x                              | x                              |
| Quad view                          | x                              | x                              |
| Remote view                        | x                              | x                              |
| Moderator Mode                     | x                              | x                              |
| Control system interface           | x                              | x                              |
| YouTube Push Mode Support          | x                              | x                              |
| Dual LAN                           | x                              | x                              |
| Mounting                           | Freestanding<br>Surface        | Freestanding<br>Surface        |
| Dimensions (W x H x D)             | 6.15 in. x 1.10 in. x 2.39 in. | 6.15 in. x 1.10 in. x 2.39 in. |

# AirMedia Network Infrastructure and Security

AirMedia leverages existing IT network infrastructure and policies. It contains a single-wired network interface with no wireless interfaces or bridges in the device. AirMedia becomes a wireless solution by utilizing the existing wireless network in the deployed network infrastructure.

---

**NOTE:** The DMPS3-4K-250-C, DMPS3-4K-350-C, and CCS-UC-1 have two LAN ports. The administrator can specify which port is used for AirMedia in the device's AirMedia configuration screen shown on page 13.

---

All policies, encryption, and other implemented security measures are applied to AirMedia as AirMedia data is identical to standard Ethernet traffic. AirMedia traffic on the corporate network is treated like any other streaming network traffic. All existing policies that apply to physical network devices (switches, routers, etc.) also apply to AirMedia. AirMedia is a standard network appliance (like a printer) and is as secure as the supporting network.

AirMedia employs a proprietary protocol to transport the screen data to the device. Average bandwidth requirements are typically low (down to 1.4 Mbit/s on AirMedia 2.0 devices such as AM-200, AM-300, DMPS3-4K-250-C, DMPS3-4K-350-C, and CCS-UC-1). Bandwidth varies depending on content, but will not drop below 0.25 Mbit/s or exceed 8.5 Mbit/s. In Windows only, the quality slider in the setting limits the peak bandwidth only, not the average or minimum bandwidth, and behaves logarithmically rather than linearly.

When using native mirroring in macOS and iOS with AM-101 and AirMedia 2.0 devices, the OS negotiates and controls the bandwidth to the AirMedia device due to the way the native mirroring protocol is defined. Official numbers are not published for minimum and maximum required bandwidth, but observed minimum and maximum numbers are similar to the AirMedia 2.0 proprietary protocol. Typical average bandwidth has been measured at approximately 5Mbit/s. However, these numbers depend largely on the type and complexity of content displayed.

It is highly recommended to upgrade all AirMedia devices to the latest firmware to ensure optimal network performance. AM-100 and AM-101 devices with the latest firmware have average bandwidth usage of 1.5Mbit/s or greater, while AM-100 devices with older firmware may have much higher bandwidth requirements on the order of over 32Mbit/s average and 46Mbit/s peak when displaying full-motion video.

The following table summarizes the bandwidth requirements for AirMedia devices.

## AirMedia Bandwidth Requirements

| TECHNOLOGY   | MINIMUM                 | TYPICAL    | MAXIMUM                 |
|--|-------------------------|------------|-------------------------|
| AirMedia 2.0   | 0.25 Mbit/s             | 1.4 Mbit/s | 8.5 Mbit/s              |
| macOS and iOS native device mirroring to AirMedia 2.0 and AM-101 | Similar to AirMedia 2.0 | 5 Mbit/s   | Similar to AirMedia 2.0 |
| AM-100 & AM-101  | 0.5 Mbit/s              | 1.5 Mbit/s | 15 Mbit/s               |
| AM-100 (Old Firmware)  | <0.1 Mbit/s             | 32 Mbit/s  | 46 Mbit/s               |

## Network Infrastructure and Design Considerations

Prior to deploying AirMedia products, it is important to assess the network infrastructure and design.

As the table in the previous section shows, AirMedia connection average bandwidth varies from the 46Mbit/s peak of the older AM-100 firmware, to 5Mbit/s average when sending with native macOS and iOS mirroring, and down to 1.4Mbit/s typical for AirMedia 2.0 devices. AirMedia 2.0 is substantially better in average and peak bandwidth, and has better quality at any given bandwidth than AM-100 and AM-101 devices.

The default peak bitrate in the Windows sender is 5Mbit/s to ensure a high-quality experience for all types of content and a high frame rate at any resolution up to 1080p at 30 frames per second.

The peak bitrate target can be lowered to 1Mbit/s on Windows senders, which is adequate for most static content types. 1080p video with high motion and detail levels, or complex motion with high foreground-background contrast such as smoke and flames, may not display in high quality at the lowest bitrates. This is due to the limitations of live video encoding and decoding on current devices. If this type of video content is played consistently, a higher bandwidth quality setting is recommended.

AirMedia 2.0 devices are designed for lower latency than the older AM-101. Latency under 100 ms has been observed in a well-designed and properly provisioned network with ideal Wi-Fi network conditions. Older devices such as the AM-101 may experience latency as high as 180 ms. It is difficult to specify actual latency due to the enormous variations found in network environments. High CPU-load applications running in the background may affect the wireless presentation experience as well.

To ensure proper bandwidth provisioning, low latency and consistent performance, the following considerations should be taken into account.

---

**NOTE:** The following techniques are not intended to be a complete list of possible issues, but are intended to give guidance to minimize disruption of the AirMedia experience to end users and administrators alike.

---

- Manage wireless network infrastructure correctly.
- Design the network architecture between the AirMedia sender and presentation gateway correctly.
- Minimize the impact of non-AirMedia device network traffic on the network.

Proper wireless access point design must be taken into account for a successful AirMedia installation. While most access point vendors offer specific guidance on this subject, the following checklist may help prevent issues at scale:

- Bandwidth requirements per access point for all use types, including AirMedia, versus the available bandwidth the access point and non-overlapping Wi-Fi channels provide.
- Placement of wireless access points both on and between floors of a building so that co-channel interference is minimized. Using different antenna types and mounting locations can assist in minimizing interference by design.

- Capabilities of the radios that the most commonly-used connecting devices will have, and take advantage of both 2.4 GHz and 5 GHz bands and newer technologies such as 802.11ac whenever possible. 5 GHz bands have far more channels and capacity than 2.4 GHz, though not all devices support both bands. Additionally, 5 GHz devices can have more limited range through walls and objects than 2.4 GHz devices.
- Minimize the use of unmanaged and unwanted wireless devices via corporate policies and control of Wi-Fi network device access.
- Conduct a wireless survey with calibrated equipment to understand coverage overlaps and holes, appropriate access point power levels, and channel bandwidths.

Most wireless equipment vendors have authorized providers of design and survey services which should be used whenever possible.

Proper network architecture between the sender and AirMedia device is key. Some considerations include:

- Minimize the number of network hops from the wireless access point to the AirMedia device.
- Use high-quality, non-blocking switches and routers with sufficient capability to move unicast streaming traffic from senders to AirMedia devices.
- Avoid scheduling processor intensive or network-intensive applications in the background, such as backup and software upgrades, at the same time the AirMedia sender is active.

Minimizing traffic from non-AirMedia devices can be challenging given end user expectations on wireless networks. There are several techniques to help ensure AirMedia traffic is prioritized:

- Keep AirMedia devices and traffic on their own VLANs and subnet, but routable from outside.
- Use quality-of-service features on switches and routers to prioritize AirMedia traffic as per the audio/video ports listed elsewhere in this document.
- Conduct network traffic flow analysis to identify network hot spots around the AirMedia device.

If Bonjour® or multicast DNS services are to be blocked, the blocking needs to occur at the switch level. If blocking occurs on a macOS or iOS sending device due to administrative policy regarding firewall settings, the native mirroring connection to AirMedia presentation gateways will not be possible without the AirMedia app. Some organizations manage mDNS and Bonjour on their network using specialized management tools that minimize broadcast chatter while still providing services. These tools can occasionally interfere with device discovery and should be configured to prevent such interference.

## Deployment Options for Guest Network Access

In meeting rooms, guests may want to present to corporate users. Keeping the guest networks and corporate networks separate while allowing the users to share a display need not be challenging. As a standard network device, AirMedia solves this problem by using standard networking practices. There are two recommended methods: the VLAN-based method, and the physical air gap method.

### VLAN

In this scenario, AirMedia devices are placed in their own VLAN. This VLAN is configured to allow only incoming connections. Outbound traffic is not allowed. The guest and corporate networks exist in separate VLANs. Since outbound connections are not allowed, the guest VLAN cannot access the corporate VLAN through the AirMedia VLAN.

#### AirMedia VLAN-Based Method Example

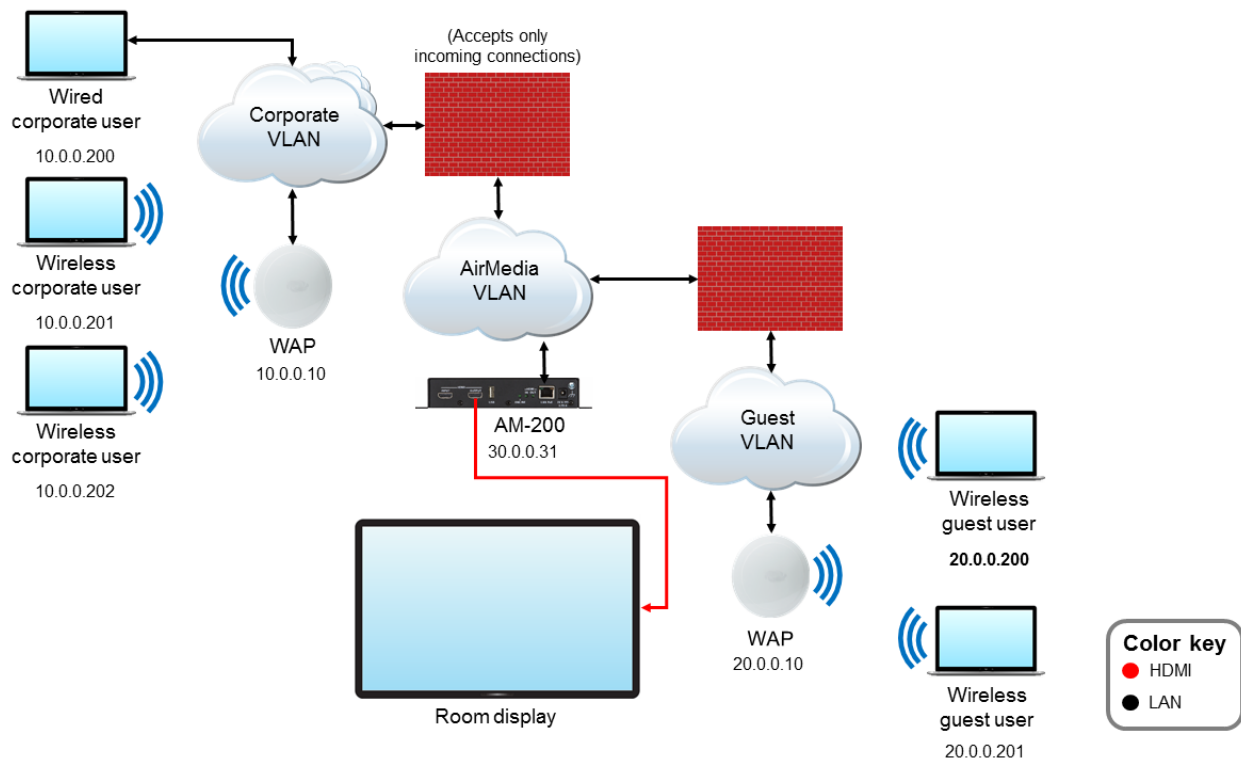

### Physical Air Gap

If networks (for security reasons) require some type of physical separation, there are two approaches when using current AirMedia devices:

- With devices such as the AM-101 that have a single network interface, two AirMedia devices can be used, one for corporate users and one for guest users.
- To switch presentations in the HDMI interface domain, use an HDMI switch such as the DMPS3-4K-250-C or DMPS3-4K-350-C. While extremely secure, this approach requires more hardware.

## AirMedia Physical Air Gap Method Example

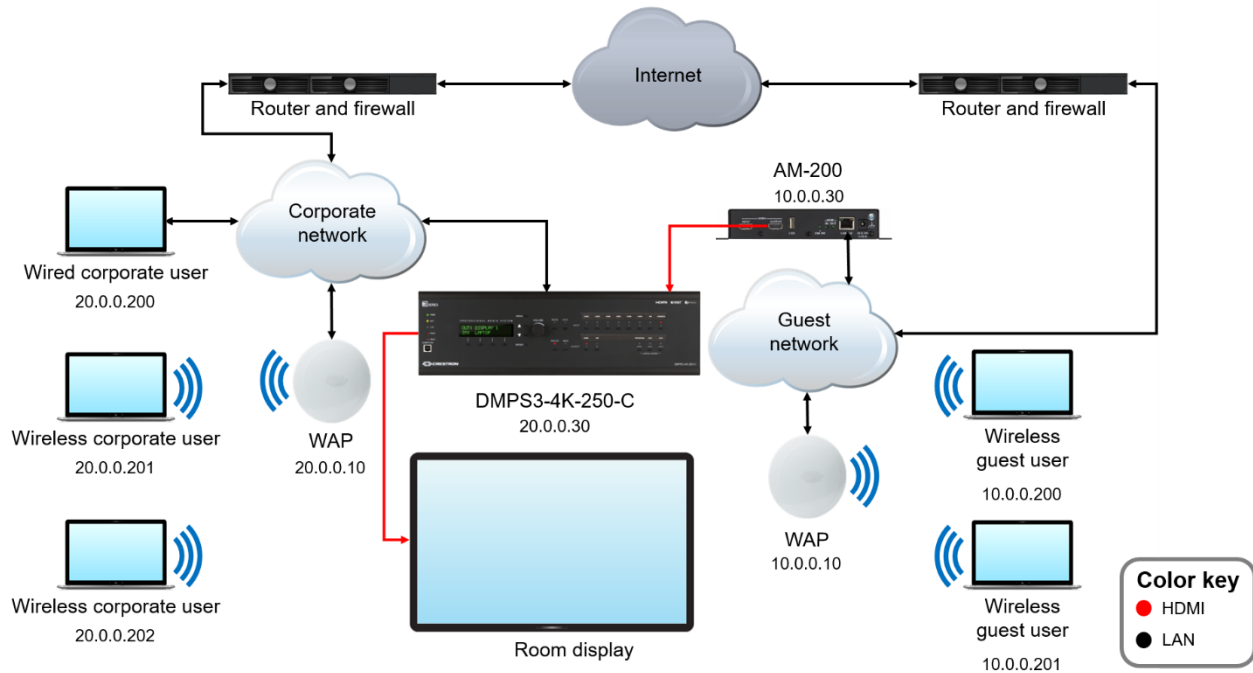

## Data Transport & Encrypted Communications

The data connection from the sender is encrypted and can only be decrypted by an authorized AirMedia device. In conjunction with wireless access point security, AirMedia content cannot be secretly eavesdropped by non-authorized parties. Correct operation of the security protocols is contingent on leaving the correct ports open for the AirMedia device at the network switch as shown in "Device Configuration" on page 12.

The AirMedia receiver within the AM-200/300 and CCS-UC-1 supports third party certificates for encrypting connections between the sender applications for Windows and Android and the receiver.

The use of third party certificates for encrypting connections can be enabled and disabled in the configuration of the product.

Please refer to the product manual for the AM-200/300 or CCS-UC-1 for instructions on how to load a certificate onto the device. If no certificate exists, the system will default to using a self-signed certificate.

The AirMedia sender applications for Windows and Android can validate the use of a trusted certificate when making a connection.

# AirMedia Device Considerations

## Device Naming

The use of IP addresses can cause confusion. Crestron recommends each AirMedia device be given a hostname that is easy for the user to remember. The IP address can be hidden from the on-screen display, which limits the amount of information presented to the user. Crestron has implemented the following automated ways of resolving a device by hostname:

- NetBIOS resolution
- DHCP options 12 and 81
- NSUPDATE for dynamic DNS servers
- Bonjour and Multicast DNS

Crestron recommends configuring either a static IP or a DHCP reservation for the IP address, as well as a DNS entry for the AirMedia device. Once the hostname is configured, the IP address display can be turned off in the AirMedia web pages.

NetBIOS is used only if the hostname is 15 characters or less and is disabled if the hostname is longer than 15 characters.

- NSUPDATE is sent under the following conditions:
- If the device is using a static address and the DNS field is populated
- If the device is using DHCP to obtain an IP address, and the **Domain Name** field in the **Network Setup** screen is not blank

---

**NOTE:** If the domain name field is blank, NSUPDATE is not sent.

---

## Device Configuration

AirMedia is configured through the built-in web pages of the device. AirMedia 2.0 devices may also be configured via the Crestron XiO Cloud service. Parameters such as the device's IP address, and connections to control systems and Crestron Connected® devices are set with a web browser. The username and password of a new device should be changed from the initial value. For AirMedia 2.0 devices, use of Active Directory® credential management for management of login information is encouraged when available.

## AirMedia Screen for AM-200, AM-300, DMPS3, and CCS-UC-1

▼ Airmedia

Code

Login Code Mode Disabled  
 Login Code Mode Random  
 Login Code Mode Use the following code

Login Code

Ethernet Adapter

Assigned Ethernet Port Adapter 1  
 Assigned Ethernet Port Adapter 2

## Device Administration Screen for AM-100 and AM-101

Device Administration
Network Setup
Logout

System Status

Device Setup

Network Setup

OSD Setup

Change Password

Firmware Upgrade

Remote View Setup

Reset to Default

Reboot System

|   |  |
|---|--|
| <b>Host Name and Domain Name</b>  | Host Name <input style="width: 100%;" type="text" value="My-AirMedia"/>  |
|   | Domain Name <input style="width: 100%;" type="text"/>  |
| Note: For maximum compatibility, host names less than 15 characters are recommended allow char: [0-9], [A-Z], [a-z], [-]. |  |
| <b>IP Setup</b>   | <input checked="" type="radio"/> Obtain an IP address automatically <input type="radio"/> Use the following IP address   |
|   | IP Address <input style="width: 20px;" type="text" value="192"/> <input style="width: 20px;" type="text" value="168"/> <input style="width: 20px;" type="text" value="100"/> <input style="width: 20px;" type="text" value="10"/>      |
|   | Subnet Mask <input style="width: 20px;" type="text" value="255"/> <input style="width: 20px;" type="text" value="255"/> <input style="width: 20px;" type="text" value="255"/> <input style="width: 20px;" type="text" value="0"/>      |
|   | Default Gateway <input style="width: 20px;" type="text" value="192"/> <input style="width: 20px;" type="text" value="168"/> <input style="width: 20px;" type="text" value="100"/> <input style="width: 20px;" type="text" value="10"/> |
|   | DNS Server <input style="width: 20px;" type="text" value="192"/> <input style="width: 20px;" type="text" value="168"/> <input style="width: 20px;" type="text" value="100"/> <input style="width: 20px;" type="text" value="10"/>      |
| <b>Crestron Control System</b>  | IP Address or Hostname <input style="width: 100%;" type="text"/>   |
|   | IPID <input style="width: 50px;" type="text" value="05"/>  |
| <b>Crestron Connected™ Device</b>   | Communication Status Offline   |
|   | IP Address or Hostname <input style="width: 100%;" type="text"/>   |
|   | Communication Status Offline   |
|   | CurrentSource None   |
|   | Source <input style="width: 50px;" type="text" value="None"/> <input type="button" value="Set"/>   |
|   | Automatic Power On <input checked="" type="radio"/> Immediately <input type="radio"/> After Code Entry   |
|   | Power Off Time Out <input style="width: 30px;" type="text" value="0"/> minutes <input type="button" value="Set"/>  |
|   | Power Control <input type="button" value="Power On"/> <input type="button" value="Power Off"/>   |
|   | Power Status Unknown   |
|   | Lamp Hours 0 hours   |
| Device Status No Error  |  |
| <input type="button" value="Apply"/> <input type="button" value="Cancel"/>  |  |

Deployment Guide – DOC. 7693L

AirMedia Presentation Gateway • 13

## Firewall Settings & Port Table

The AirMedia application requires firewall rules to allow it to communicate with AirMedia devices. Crestron requires creating a rule for the application that allows all traffic to pass to the device. If the rule is not created, the operating system prompts the user with the option to add a rule. This may require administrator privileges.

For the set of ports that allow the client to communicate with the device, refer to the tables below.

**Port Map 1: Ports Used by AirMedia 2.0 Presentation Gateways (AM-200, AM-300, DMPS3, CCS-UC-1)**

| PORT      | TYPE | DIRECTION (CLIENT) | DIRECTION (RECEIVER) | FUNCTION        | OPEN        | NOTES   |
|-----------|------|--------------------|----------------------|-----------------|-------------|---|
| 5353      | UDP  | Both               | Both                 | Discovery       | Optional    | This port is for AirMedia Presentation Gateway discovery. If this port is blocked, automatic network discovery will not function correctly. |
| 6000-7000 | TCP  | Outbound           | Inbound              | Video           | Required    | These ports carry audio and video streams. If these ports are blocked, AirMedia will not function.  |
| 6000-7000 | UDP  | Both               | Both                 | Audio           | Required    | These ports carry audio and video streams. If these ports are blocked, AirMedia will not function.  |
| 7011      | TCP  | Outbound           | Inbound              | Control Channel | Required    | This port carries control channel information. If this port is blocked, AirMedia will not function.   |
| 7100      | TCP  | Outbound           | Inbound              | Control Channel | Required    | This port carries control channel information. If this port is blocked, AirMedia will not function.   |
| 7200      | TCP  | Outbound           | Inbound              | Control Channel | Required    | This port carries control channel information. If this port is blocked, AirMedia will not function.   |
| 7201      | TCP  | Outbound           | Inbound              | Control Channel | Required    | This port carries control channel information. If this port is blocked, AirMedia will not function.   |
| 7236      | TCP  | Inbound            | Outbound             | Audio/Video     | Recommended | Required if using Miracast. These ports carry audio and video streams.  |
| 7250      | TCP  | Outbound           | Inbound              | Control Channel | Recommended | Required if using Miracast. This port carries control channel information.  |
| 7300      | TCP  | Outbound           | Inbound              | Control Channel | Recommended | Required if using the AirMedia Google Chrome™ Extension*. This port carries control channel information.                                    |

| PORT  | TYPE | DIRECTION (CLIENT) | DIRECTION (RECEIVER) | FUNCTION        | OPEN     | NOTES   |
|-------|------|--------------------|----------------------|-----------------|----------|---|
| 47000 | TCP  | Outbound           | Inbound              | Control Channel | Required | This port carries control channel information. If this port is blocked, AirMedia will not function. |
| 47010 | TCP  | Outbound           | Inbound              | Audio, Video    | Required | This port carries audio and video. If this port is blocked, AirMedia will not function.             |

\*Note: The AirMedia Google Chrome Extension uses WebRTC based screen mirroring and may utilize other ports dynamically.

## Port Map 2: Ports Used by the AirMedia Windows Guest and Deployable Applications with the AM-100 and AM-101

| PORT                 | TYPE | DIRECTION | FUNCTION          | OPEN        | NOTES  |
|----------------------|------|-----------|-------------------|-------------|--|
| 80                   | TCP  | Both      | Projector Control | Optional    | This port is used to turn on a Crestron Connected projector. If this port is blocked, the device functions normally, but the automatic projector power on feature does not work.   |
| 389<br>443<br>445    | TCP  | Both      | Control Channel   | Required    | For best performance, Crestron recommends that ports 389, 443, and 445 be open. At a minimum, one port needs to be open for the device to function properly. If only one port is open and that port is used by another application, AirMedia will not function properly. |
| 515                  | TCP  | Both      | Video             | Required    | This port is for the video data channel.   |
| 1041                 | TCP  | Outbound  | Control Channel   | Required    | If this port is not open, AirMedia does not function properly.   |
| 1047<br>1048<br>1049 | UDP  | Inbound   | Discovery         | Optional    | These ports are used for device discovery. If the port is closed, AirMedia may not be able to find devices automatically.  |
| 1688                 | TCP  | Both      | Audio             | Recommended | This port is for the audio data channel.   |
| 3268                 | TCP  | Both      | Control Channel   | Required    | This port is used as part of the screen sharing process.   |
| 7000                 | TCP  | Both      | Control Channel   | Required    | This port is used for client control of the device. If this port is closed, the AirMedia Presentation Gateway will not function correctly.   |
| 7100                 | TCP  | Both      | Control Channel   | Required    | This port is used for client control of the device. If this port is closed, the AirMedia Presentation Gateway will not function correctly.   |
| 7200 -<br>7201       | TCP  | Both      | Control Channel   | Required    | This port carries control channel information. If this port is blocked, AirMedia will not function.  |
| 8080                 | TCP  | Both      | Video             | Required    | This port is for the video data channel. If the port is not open, AirMedia does not function properly.   |
| 19996                | TCP  | Both      | Future            | Optional    | This port is reserved for future use.  |
| 31865                | TCP  | Both      | Discovery         | Optional    | This port is used for device discovery. If this port is closed, AirMedia may not be able to find devices automatically.  |

| PORT  | TYPE | DIRECTION | FUNCTION        | OPEN     | NOTES  |
|-------|------|-----------|-----------------|----------|--|
| 47000 | TCP  | Both      | Control Channel | Required | This port is used for client control of the device. If this port is closed, the AirMedia Presentation Gateway will not function correctly. |

### Port Map 3: Ports Used by AM-101 for macOS, iOS and Android full-screen mirroring

| PORT        | TYPE     | DIRECTION | FUNCTION        | OPEN     | NOTES   |
|-------------|----------|-----------|-----------------|----------|---|
| 4100 - 4101 | UDP      | Both      | Control Channel | Required | This port carries control channel information. If this port is blocked, AirMedia will not function.   |
| 5353        | UDP      | Both      | Discovery       | Optional | This port is for AirMedia Presentation Gateway discovery. If this port is blocked, automatic network discovery will not function correctly. |
| 6000-7000   | TCP, UDP | Both      | Audio, Video    | Required | These ports carry audio and video streams. If these ports are blocked, AirMedia will not function.  |
| 7011        | UDP      | Both      | Control Channel | Required | This port carries control channel information. If this port is blocked, AirMedia will not function.   |
| 7200 - 7201 | TCP      | Both      | Control Channel | Required | This port carries control channel information. If this port is blocked, AirMedia will not function.   |
| 47010       | TCP      | Both      | Audio, Video    | Required | This port carries audio and video. If this port is blocked, AirMedia will not function.   |

### Port Map 4: Ports Used by the AirMedia Presentation Gateway (AM-100 and AM-101)

| PORT           | TYPE | DIRECTION | FUNCTION          | OPEN     | NOTES   |
|----------------|------|-----------|-------------------|----------|---|
| 21             | TCP  | Both      | Update Utility    | Optional | This port is used only to transfer the firmware to the device with the batch update application. This port is not used when updating with the web interface.                    |
| 80             | TCP  | Both      | Web Services      | Required | This port is used to access the AirMedia device configuration website.  |
| 137            | TCP  | Both      | NetBIOS Discovery | Optional | This port allows the device to be resolved without a DNS server present. This port is enabled if the hostname is fewer than 15 characters.                                      |
| 138            | UDP  | Both      | NetBIOS Discovery | Optional | This port allows the device to be resolved without a DNS server present. This port is enabled if the hostname is fewer than 15 characters.                                      |
| 41794          | TCP  | Both      | Control System    | Required | This port is used to control Crestron Connected devices.  |
| 42891<br>42892 | TCP  | Both      | Update Utility    | Required | These ports are used to control firmware updates and are used only with the batch update application. These ports are not used when updating the device with the web interface. |

# Device Upgrades

## Single Device (Web Interface)

All AirMedia Presentation Gateways support firmware upgrades via their web interfaces. Use the web interface to upload a single file containing the firmware. Firmware upgrades may take 15 to 30 minutes to complete (depending on the device), and should be performed only outside of normal operating hours.

## Multiple Devices

The firmware of AirMedia 2.0 products such as AM-200, AM-300, DMPS3, and CCS-UC-1 can be upgraded through Crestron XiO Cloud Service. For details, refer to the Crestron XiO Cloud Service User Guide (Doc. 8214) at [www.crestron.com/manuals](http://www.crestron.com/manuals).

Crestron provides an application for upgrading multiple AirMedia devices (AM-100 and AM-101). The application reads room list files to simplify management. Devices can be upgraded one at a time, or in a batch operation. To upgrade AirMedia devices, the user needs to connect to an FTP server. The application provides an FTP server or AirMedia can be configured to use an external FTP server. The application is available at [present.crestron.com](http://present.crestron.com).

# Control

AirMedia Presentation Gateways have multiple control options depending on the model and the specific needs of the room and overall facilities.

## .AV Framework and Crestron XiO Cloud Service

AirMedia 2.0 Presentation Gateways come with .AV Framework functionality. .AV Framework provides a web interface of options that define inputs, outputs and connected devices standard behavior. Some of these options include the ability to add Zūm space occupancy sensors and switches, 60-series TSW control panels, and controls for the most commonly used room displays. Other behaviors, such as scheduling a display device's power-on and power-off times are also definable depending on the specific product and its capabilities.

With Crestron XiO Cloud Service, AirMedia Presentation Gateways provision settings such as network configuration across an enterprise. The settings are stored in the cloud with the ability to monitor and control a worldwide enterprise. Crestron XiO Cloud Service is also the central license management mechanism for devices such as DMPS3 and CCS-UC-1 which have transferrable AirMedia licenses and allow for seamless upgrades.

---

**NOTE:** .AV Framework and Crestron XiO Cloud Service are not available on the AM-100 or AM-101.

---

Consult the product documentation for each AirMedia 2.0 device for instructions on how to configure .AV Framework and Crestron XiO Cloud Service.

## Crestron Connected

AirMedia devices can control any Crestron Connected compatible display. When launching the application, a "power on" command is sent to the display, eliminating the need for a remote control or the press of a power button.

To use the Crestron Connected feature, the user provides the display's IP address or IP ID. When a user connects to the AirMedia device, a command is issued to turn on the display. After the last user disconnects from the AirMedia device, a command is issued to turn off the display.

For more information on Crestron Connected devices, refer to <https://www.crestron.com/en-US/Products/Crestron-Connected-Devices>

## Control System

The AM-100, AM-101, and DMPS3 can integrate with Crestron 3-Series® control systems for complete room control. When a Crestron control system is used, lights, display, HVAC, shading, and virtually any other device in the room can be controlled.

Additionally, the control system can implement Simple Network Management Protocol (SNMP) to integrate with existing IT management tools. The device parameters can be set and monitored by a Crestron control system, as shown in the Device Parameters table below.

### Device Parameters

| NAME                      | ACCESS     | TYPE   | FUNCTION   |
|---------------------------|------------|--------|--|
| Status                    | Read       | Analog | Reports the status of the device   |
| Number of Users Connected | Read       | Analog | Indicates the number of users currently connected  |
| Device Access Code        | Read       | Analog | Sets the device access code<br><b>NOTE:</b> The input sets the current code and is only valid when the device code is in Fixed mode (configured through the device's web pages). |
| Projector Connected       | Read/Write | Analog | Reports the status of a connected projector<br>Valid Values:<br>0 = Not connected<br>1 = Connected   |
| Status Text               | Read       | Serial | Returns the status of the device as a string for display   |

### Device Parameters Table (Type Column) Key

| CRESTRON TYPE | STANDARD TYPE                     |
|---------------|-----------------------------------|
| Digital       | Boolean                           |
| Analog        | 16-bit integer                    |
| Serial        | String (maximum length 255 bytes) |

Crestron Fusion® software can also provide an alternative monitoring mechanism to SNMP. For more information on Crestron Fusion software, refer to [www.crestron.com/en-US/Products/Featured-Solutions/Crestron-Fusion](http://www.crestron.com/en-US/Products/Featured-Solutions/Crestron-Fusion).

# Deploy AirMedia Sender Applications to PCs

While PC users can download the sender application for their operating system from an AirMedia device, IT departments can also deploy the sender application to PCs across the enterprise.

## Windows

Enterprises require both flexibility and control of the installation options of any application, particularly when mass deployment is required. The AirMedia Deployable application Windows installer is a Microsoft® Software Installer (.msi) file that provides the necessary means to control installations in such environments.

The AirMedia Windows Deployable Application is available at [present.crestron.com](http://present.crestron.com) or from the corresponding AirMedia product page.

---

**NOTE:** A login for the Crestron website is required to access the deployable application from the product page.

**NOTE:** The AirMedia deployable application does not automatically update itself. To update the application, uninstall any previous version of the application and install the latest version using the method below. An account with administrative privileges must be used during installation, or correct installation will not occur.

---

The Windows installer can be run using either of the following methods:

- Through Microsoft Group Policy for mass deployment
- Through the Windows command line.
- Administrators can set up a Group Policy Object (GPO) to script the installation to use the next time the user logs into their Windows system. The default behavior of executing the .msi file without any command line options is to do the following:
  - Install the application in its default location (C:\Program Files (x86)\Crestron\AirMediaV2)
  - Install desktop and Start menu shortcut icons
  - Start automatically
  - End users installing the application for the first time without any options are immediately presented with the connection information entry dialog after installation.

To use the installer with command line options, the "msiexec" function must be used in conjunction with the .msi file as specified below.

---

**NOTE:** If the .msi file is executed without using the msiexec application as shown, no options will be respected at the command line, and the sender application will silently install and present the connection window for entry of IP address or host names.

---

The general format for running the installer is as follows:

```
msiexec /I AirMedia_Windows_<VERSION>_deployable.msi /qn <OPTIONS>
```

- /I is the command line switch that tells msiexec to install the msi (required)
- <VERSION> is the version number of the deployable .msi file
- /qn is the command line switch that suppresses .msi dialogs
- <OPTIONS> is one or more of the following options, separated by spaces:
  - INSTALLATIONMODE=--silent - suppresses the launching of the AirMedia application after installation is complete (the default behavior is to launch the AirMedia application)

When the option is silent and /qn is used, the installer will suppress any installer dialogs and the application will not be launched after installation

- INSTALLPATH=<PATH> - installs the application in the specified path on the device rather than the default location
- SHORTCUTOPTION=<OPTION> - installs shortcuts according to one of four specified options:
  - --none - installs no shortcuts
  - --desktop - installs application shortcut only to the desktop
  - --menu - installs application shortcut only to the Start menu
  - --all - installs application shortcut to both the desktop and the Start menu

Examples of .msi installation are as follows:

- ```
msiexec /I AirMedia_Windows_3.0.1.254_deployable.msi/qn  
INSTALLATIONMODE=--silent SHORTCUTOPTION=--menu
```

This command installs the AirMedia sender application silently, without any dialogs or notifications, with only the **Start** menu shortcut installed, and without the sender application starting after installation.

- ```
msiexec /I AirMedia_Windows_3.0.1.254_deployable.msi/qn  
INSTALLATIONMODE=--silent INSTALLPATH=D:\AirMedia
```

This command installs the AirMedia sender application with desktop and **Start** menu shortcuts, and in a path not on the main Windows partition of the machine.

- ```
msiexec /I AirMedia_Windows_3.0.1.254_deployable.msi
```

This command may be used to observe the behavior of the installer as it installs the AirMedia sender application on a machine to validate its operation visually.

## macOS

The same enterprise flexibility and control of installation options in the Windows deployable application is also available for macOS. The macOS installer is a .zip archive file containing the AirMedia application as an executable that provides the ability to customize installations in enterprise environments.

The deployable application for macOS is available at [present.crestron.com](http://present.crestron.com) or from the corresponding product page.

---

**NOTE:** A login for the Crestron website is required to access the deployable application from the product page.

**NOTE:** For AM-100 installations, the macOS installer should be used for sharing audio and video as the macOS installer has a user-mode driver that is installed alongside the application. The driver is not available with the guest application version. For consistent functionality, the PC may require rebooting after installation.

---

The macOS installer can run in the following ways.

- Open the .zip archive file, and run the installer file inside.

After installation, the sender app appears in the macOS dock and the /Applications/Crestron folder, and the sender app is launched. Upon installation, end users will have a fast connection experience with easy access to the sender application.

- Use the .pkg file within the installer for administrators to silently install the application on users' machines. The sender app does not run after installation completes, and the UI is not displayed. Inside the pkg archive file is the InstallAirMedia.app bundle. The app bundle contains the required airmedia\_osx\_installer.pkg package file in the Content/Resources folder. On a terminal, issue the following command to run the installer:

```
sudo installer -pkg airmedia_osx_installer.pkg -target /
```

The AirMedia sender application can be installed silently (without user knowledge) on a macOS PC using Apple policies, MDM, or other similar management tools. Options for installation of desktop icons and specifying installation location are not available due to the conventions of the macOS platform.

The deployable application provides flexibility when managing the challenges of AirMedia rooms installed in multiple campus locations with various levels of employee access. To address the various deployment scenarios, AirMedia provides the following methods to access a room's connection parameters:

- **Room Lists:** The AirMedia client application reads an XML file containing a list of AirMedia rooms and displays them in the **Connect** screen as a list of AirMedia devices that are available for connection

---

**NOTE:** Room lists require the creation of a config.ini file and an XML file. For details, refer to "Configure Room Lists" on page 22.

---

- **File Association:** The AirMedia client application is associated with .present files and room list files. Embed the .present files in meeting invitations or host them on a corporate website.
- **Discovery:** If the AirMedia devices and the user's computer are on the same subnet, the AirMedia client application locates these devices and presents them to the user. Crestron recommends this method if a room list or .present file is not used.
- **Manual Entry:** The application allows the user to enter the hostname or IP address of the AirMedia device.
- Device discovery differs from the PC in one important aspect. In macOS (and iOS), the AirMedia sender applications are technically not required if multicast DNS or Bonjour are not blocked on the network where AirMedia Presentation Gateways reside. Multicast DNS and Bonjour allow a list of compatible native mirroring devices for macOS and iOS to appear in a list natively provided by the OS. However, the list can also contain a large number of non-Crestron discoverable gateways, making it difficult for users to search for and manage AirMedia devices. Additionally, users may not always be familiar with the procedure for connection via native mirroring. Crestron recommends using the AirMedia application for all connections from macOS and iOS.

---

**NOTE:** The AM-100 is not compatible with native device mirroring provided by macOS and iOS. The AirMedia sender application must always be used with the AM-100.

---

## Configure Room Lists

In some organizations, room lists can be used to maintain the full list of AirMedia Presentation Gateways on the network. This list can be easily searched without the need to enter an IP address or host name. To implement room lists, two files must be prepared, a config.ini, and an XML room list that is pointed to by the config.ini. The contents and locations of these files are shown below.

### Configuration File (config.ini)

Crestron software uses a common repository for user-specific data on Windows and macOS to store its config.ini file. Examples of user directory locations for Windows 8 and macOS are shown below (for the user name TestUser):

**Windows:** C:\Users\TestUser\AppData\Roaming\Crestron\AirMedia

**macOS:**

/Users/TestUser/Library/Containers/com.crestron.AirMedia2/Data/Library/Application Support/Crestron/AirMedia/Configure/

After the folder is created, the configuration file must be created if using a Windows operating system (on macOS, a blank file is automatically created). The config.ini file contains the location of the room list XML file. The file contains two items: the section Crestron and the key XMLPath. An example of a config.ini file is shown below.

```
[Crestron]
XMLPath=M:\config\airmedia\room_list.xml
```

When the AirMedia application starts, it attempts to read the file at the location specified by the XMLPath. Note the following when specifying an XML path:

- Do not enclose the path in quotes.
- Environmental variables are not supported.
- When updates are necessary, a change to this file either by administering the file locally or on the network will quickly allow users access to the available AirMedia rooms.
- On Windows:
  - Local and network paths are allowed.
  - HTTP/HTTPS paths are allowed.
- On macOS:
  - Network paths are not allowed.
  - HTTP/HTTPS paths are allowed.
  - Certain local paths are allowed (Desktop, Documents, Applications, Downloads, Movies, Music, Pictures, Public or locally mapped cloud service directories such as Dropbox®, Google Drive™, OneDrive®, Box, or iCloud).

## Room List (XML File) for Windows and macOS

The room list file is an XML file that defines the devices and their connection parameters. The specifics of the XML file schema are defined in the table below.

### Room List File Details

| TAG     | DESCRIPTION                                                                                                                                                                                  | EXAMPLE FOR WINDOWS AND MACOS                                                                                                                                                                                                                                                                                                                                                                                                                                                              |
|---------|----------------------------------------------------------------------------------------------------------------------------------------------------------------------------------------------|--------------------------------------------------------------------------------------------------------------------------------------------------------------------------------------------------------------------------------------------------------------------------------------------------------------------------------------------------------------------------------------------------------------------------------------------------------------------------------------------|
| devices | This is the main container for the room list file. Each file must contain only one set of tags.                                                                                              | <pre>&lt;?xml version="1.0"?&gt; &lt;devices&gt;   &lt;device&gt;     &lt;name&gt;Room 239&lt;/name&gt;      &lt;address&gt;192.168.0.184&lt;/address&gt;     &lt;code&gt;5885&lt;/code&gt;   &lt;/device&gt;   &lt;device&gt;     &lt;name&gt;Room 240&lt;/name&gt;      &lt;address&gt;192.168.0.186&lt;/address&gt;   &lt;/device&gt;   &lt;device&gt;     &lt;name&gt;Room 241&lt;/name&gt;      &lt;address&gt;192.168.0.186&lt;/address&gt;   &lt;/device&gt; &lt;/devices&gt;</pre> |
| device  | This is the container for each device to be displayed. The file may contain one or more set of tags.                                                                                         | Both                                                                                                                                                                                                                                                                                                                                                                                                                                                                                       |
| name    | This is the display name for the AirMedia device that is shown in the Device Name column of the application.                                                                                 | Both                                                                                                                                                                                                                                                                                                                                                                                                                                                                                       |
| address | This is the IP address of the AirMedia device. This field is currently limited to IPv4 addresses only.                                                                                       | Both                                                                                                                                                                                                                                                                                                                                                                                                                                                                                       |
| code    | This tag is used to limit access to AirMedia. The tag can be disabled, randomly generated, or fixed to a specific value. In fixed mode, the code tag may be used to specify the access code. | Both                                                                                                                                                                                                                                                                                                                                                                                                                                                                                       |

## File Association for Windows and macOS

The .present files contain the parameters that are used to start a connection. A web server can host these files or the files can be deployed to folders within the user's computer. The installer makes the association.

The .present file uses the same format as the device section of the room list file.

To connect using file association, double-click a .present file to launch the application. If prompted, enter the login code in the **Login** screen and click **OK**.

**NOTE:** If a Crestron Connected display is used, the display turns on automatically.

## Discovery

If a room list file is not located when AirMedia opens, the application scans the local subnet for connection devices. If only one device is located, the application tries to connect to that device. If multiple devices are located, the application displays a list of connection devices. Select a gateway from the list and click **Connect**.

### Connect Screen

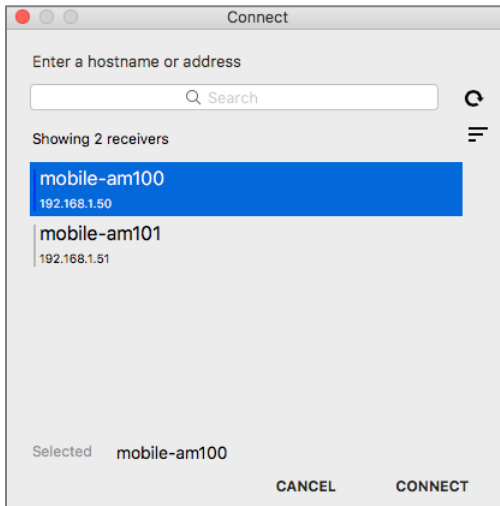

## Manual Entry

If the application is unable to discover any devices, the user can manually enter the information.

From the **Connect** dialog box, enter the hostname or IP address of the device, and then click **Connect**. If a passcode is required on the target device, the **Passcode** screen displays.

### Manually Entering Device Information

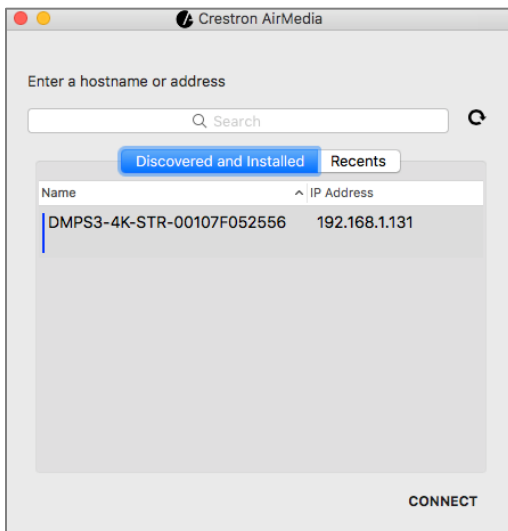

## Custom URI Protocol

A custom web landing page may be built to accommodate an organization's receivers. When launching an installed application in a browser, the client-side script in the browser uses a custom protocol (**crestron-airmedia**) as defined by the DM Connections Method Specification. The rules for the custom protocol must follow the guidelines as defined by [RFC 3986: URI Generic Syntax](#).

There are two options to define the URI format for launching the application (option 1 is recommended):

1. `crestron-airmedia://receiver-address[?code=receiver-passcode]`
2. `crestron-airmedia:receiver-address[?code=receiver-passcode]`

**receiver-address** is the hostname or address of the Airmedia Receiver, and **receiver-passcode** is the optional passcode parameter for authorizing the mirroring session.

---

**NOTE:** In order to prevent unauthorized users from starting a mirroring session, the AirMedia landing page does not contain the passcode option. Using the **receiver-passcode** parameter must be considered when designing a custom page, taking into account the security needs of the institution.

---

## Use AirMedia

An AirMedia-equipped room is simple to use. Visitors to an AirMedia room are greeted with a welcome screen that provides instructions for connecting to AirMedia. AirMedia users with a PC can use a web browser to download a guest application from the device or use an installed version of the application.

AirMedia users with a mobile device can use mobile apps for Android and iOS devices. For details, refer to "Connect to AirMedia Devices with Mobile Applications" on page 45.

### Welcome Screen

AirMedia devices show a welcome screen on a connected display device to convey the connection instructions for guest access. The welcome screen can also be configured to show custom login instructions and branding, as well as the hostname, IP address (optional), and login code for the AirMedia device.

## AirMedia Welcome Screen for AM-200, AM-300, DMPS3, and CCS-UC-1

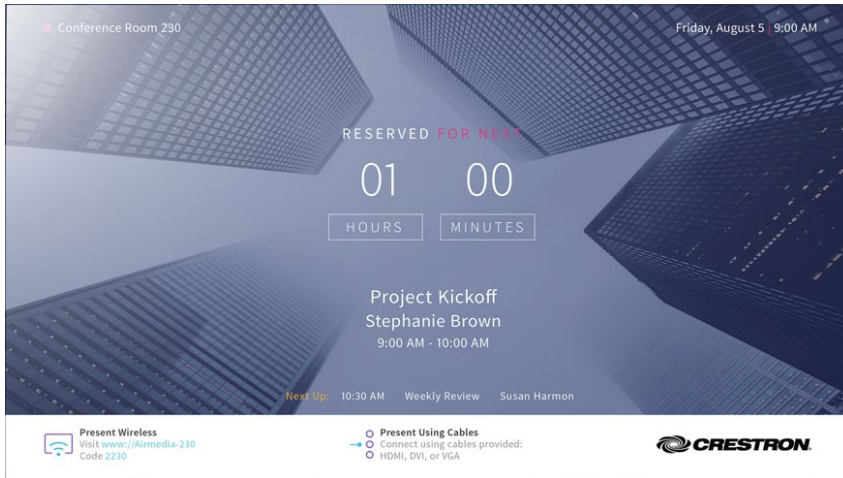

## AirMedia Welcome Screen for AM-100 and AM-101



## Connection Experience

The guest applications for Windows or macOS may be downloaded from [present.crestron.com](http://present.crestron.com), a device's built-in web page, or from the device's product page on the Crestron website ([www.crestron.com](http://www.crestron.com)).

Accessing the AirMedia 2.0 device's built-in web page allows the user to download the guest applications and automatically initiate a connection to the receiver. To initiate a connection this way, perform the following steps:

1. Open a web browser and enter the AirMedia device's IP address or hostname into the address bar.
2. Click **Start Presenting**.



The built-in web page will automatically detect the type of device the user is trying to connect from, guide the user on how to connect, and where applicable, automatically launch and initiate a connection to the receiver. If a required application is not already installed, the system will provide the installation for that particular device.

## Login Code

A login code can be displayed to help prevent unauthorized users from connecting to a device. When connecting to an AirMedia device, the user is prompted to enter a code in the **Enter AirMedia Code** dialog box. The code is only four digits, and is easy for the user to remember while still preventing unwanted presentations.

### Enter AirMedia Code Dialog Box

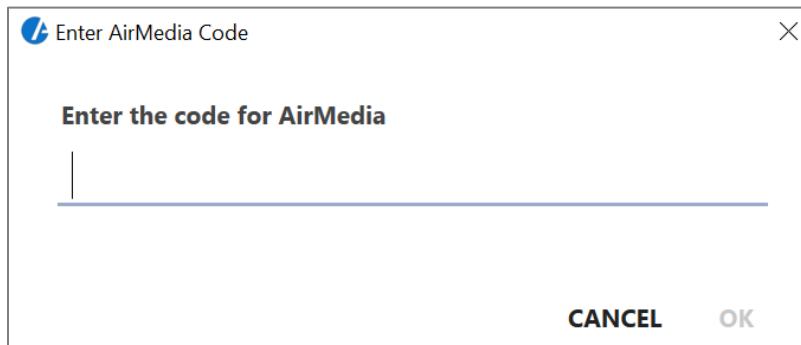

There are three modes of operation:

- **Disabled:** A login code is not required.
- **Random:** A login code is generated after all active users disconnect.
- **Fixed:** A login code can be set in the web administration pages (static). It can also be programmed using a control system for AirMedia devices that connect to Crestron control systems, or via Crestron XiO Cloud Service for devices that support Crestron XiO Cloud Service provisioning.

---

**NOTE:** The **Fixed** setting should be selected for regular users who want to remember a login code. Otherwise, the **Random** setting is recommended to prevent unintended connections.

**NOTE:** Any changes to the login code will take effect when all senders are disconnected from AirMedia.

---

For information on setting the mode of operation, refer to the AirMedia device's product manual or supplemental guide.

## PC Sender Applications

The AirMedia sender applications for Windows and macOS PCs are the most common way for users to share content through an AirMedia device. There are two types of applications available:

- **Guest Application:** Download the guest applications for Windows or macOS from [present.crestron.com](http://present.crestron.com), a device's built-in web page, or from the device's product page on the Crestron website ([www.crestron.com](http://www.crestron.com)).
- **Deployable Application:** Download the deployable applications for Windows or macOS from [present.crestron.com](http://present.crestron.com) or from the device's product page on the Crestron website ([www.crestron.com](http://www.crestron.com)).

---

**NOTE:** For more information on connecting to AirMedia with a Windows or macOS PC, refer to "User Experience with Windows" on page 29 or "User Experience with macOS" on page 35.

---

The guest and deployable applications are compatible with the operating systems shown in the following table.

### Operating System Compatibility Chart

| OPERATING SYSTEM | VERSIONS SUPPORTED                               |
|------------------|--------------------------------------------------|
| Windows          | Windows 7, Windows 8, Window 8.1, and Windows 10 |
| macOS            | macOS version 10.10 or later                     |

## User Experience with Windows

This section provides information on the AirMedia user experience when using a PC running Windows. The Windows guest application is a small file that is downloaded from the AirMedia device and runs with standard user permissions. The IP address of the AirMedia device is encoded in the filename of the application so the application can connect to the AirMedia device upon startup. The user can save the application locally, which allows for a direct connection to the device the next time the user accesses the application.

### AirMedia Guest Application

To download and run the guest application from the **AirMedia** device, complete the steps below.

On an AirMedia 2.0 device:

1. Open a web browser and enter the AirMedia device's IP address or hostname into the browser.
2. Click **Start Presenting**.



3. Click the **Windows** button to download the Windows AirMedia software.

#### AirMedia Download Screen for AM-200, AM-300, DMPS3, and CCS-UC-1

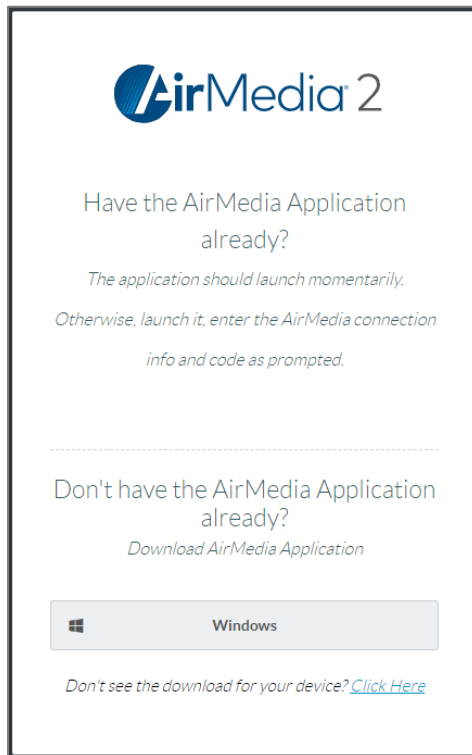

On an AM-100 or AM-101:

1. Open a web browser and enter the AirMedia device's IP address or hostname into the address bar.
2. Click the **Download** button next to **Client for Windows**.

## AirMedia Download Screen for AM-100 and AM-101

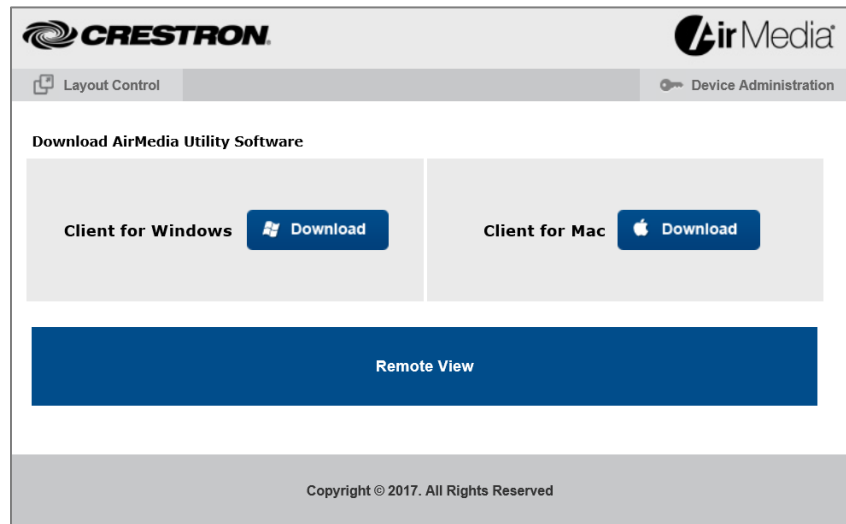

Install the application:

1. Run the application.

---

**NOTE:** If the downloaded application was previously closed and restarted on the PC, a list of AirMedia devices is displayed if the Autodiscovery feature is enabled in the application's settings (otherwise, click the refresh icon to detect devices). Select the device to connect to, and then click **CONNECT**.

---

2. If prompted, enter the login code shown on the connected display. On an AM-100 or AM-101, if a Crestron Connected® display is connected and configured for operation, the display turns on automatically during this process.

The presentation session begins immediately following the entry of the code or, if no code is required, upon entry of the IP address or host name.

On AirMedia 2.0 Presentation Gateways, other senders can connect and begin presenting. A maximum of 32 Windows or Android senders can connect simultaneously, although only the last device to connect will be able to present. Previously connected senders that may be presenting are stopped. Other senders can restart a presentation by pressing the **Start** button in the application.

For details on using the application, refer to the AirMedia device's product manual or supplemental guide.

---

**NOTE:** The guest application for Windows can also be downloaded from [present.crestron.com](http://present.crestron.com) and distributed to websites or other media for users to download. The guest application can be distributed with the connection parameters embedded in the file name so the user only has to enter the login code (if required).

The supported formats are:

<any\_text>\_<ip\_address>.exe

<any\_text><ip\_address>.exe

The underscore and dot must precede the IP address, for example:  
[executive\\_conference\\_room\\_10.1.1.13.exe](#).

---

## AirMedia Deployable (Installed) Application

The deployable application shows the user a list of devices on the **Connect** dialog box. The user can select a device for connection or search for a device within a longer list of devices.

To connect to a device, perform the following procedure.

1. Launch AirMedia. The **Connect** dialog box is displayed.

### Connect Dialog Box

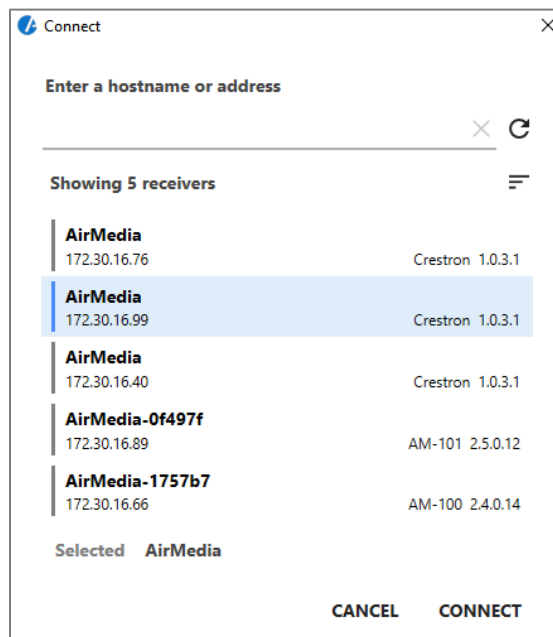

2. From the **Connect** screen, select the desired gateway from the list.

This list can also be populated with a room list file. Refer to "Configure Room Lists" on page 22.

3. Click **Connect**. If prompted, enter the login code.

#### Login Code Screen

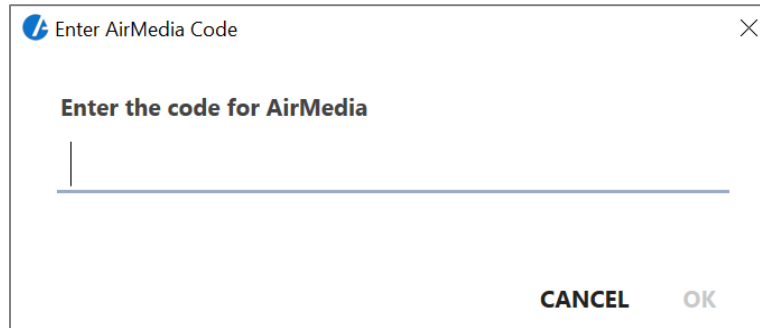

On an AM-100 or AM-101, if a Crestron Connected display is used, the display turns on automatically during this process. The presentation session begins immediately following the entry of the code or, if no code is required, upon entry of the IP address or host name.

On AirMedia 2.0 Presentation Gateways, other senders can connect and begin presenting. A maximum of 32 Windows or Android senders can connect simultaneously, although only the last device to connect will be able to present. Previously connected senders that may be presenting are stopped. Other senders can restart a presentation by pressing the **Start** button in the application.

For details on using the application, refer to the AirMedia device's product manual or supplemental guide.

#### Launch with Automatic Connection

For custom deployments, the application can also be launched and connected with a device automatically using the following command in a Windows command prompt:

```
start present:<IP_ADDRESS>?code=<CODE>
```

where <IP\_ADDRESS> is the IPv4 address of the AirMedia device and <CODE> is the login code for the AirMedia device.

## Miracast® Presentation

Miracast technology allows users to wirelessly share content from a Microsoft Windows 10 device. Miracast technology is built into the Microsoft Windows 10 operating system, so no software installation is required. This is an alternative to using the AirMedia application for Windows. Miracast presentation is currently supported on the AM-200, AM-300, and CCS-UC-1 models.

---

**Note:** The AM-USB-WIFI or the AM-USB-WIFI-I wireless adaptor is required when using Miracast. For more information on Miracast please refer to [Miracast on AirMedia 2.0](#) on page 41.

---

Press the **Windows key + K** to display a list of nearby wireless devices. Click an AirMedia 2.0 device to begin streaming.

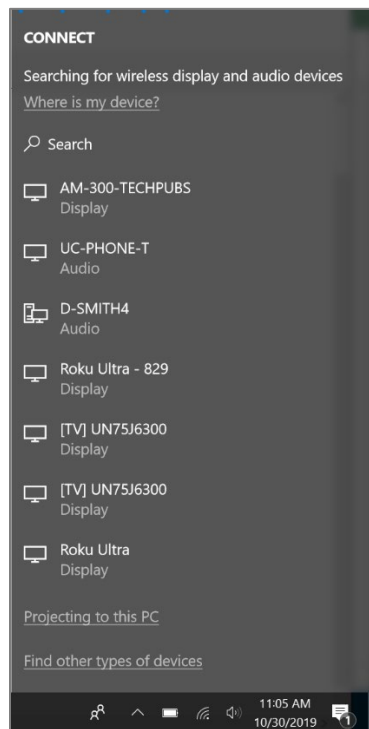

While streaming, click **Disconnect** to disconnect from the device and end the stream, or click **Change projection mode** to choose how content is displayed.

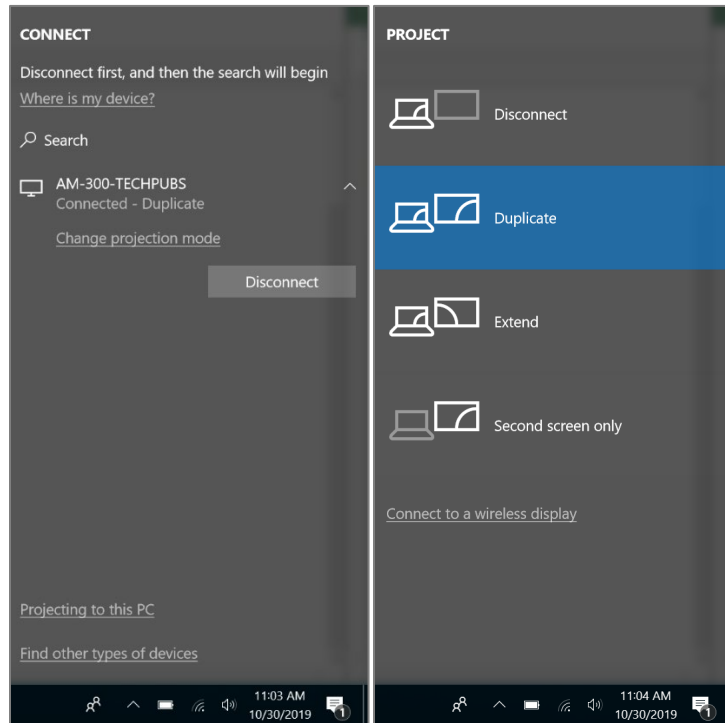

- **Disconnect** disconnects from the device, ending the stream.
- **Duplicate** shows the screen on both the computer and the display.
- **Extend** splits the image between the computer and the display.
- **Second screen only** displays the screen only on the display.

## User Experience with macOS

The basic macOS user experience is similar to that of Windows, but has some important differences as discussed below.

### AirMedia Guest Application

The macOS guest application is a small file that is downloaded from the AirMedia device, and runs with standard user permissions. The user needs to open the .zip package and then run the guest application within the package. The IP address of the AirMedia device is encoded in the filename of the application so the application can connect with the AirMedia device upon startup. The user can save the .zip package locally, which enables direct connection to the device the next time the user accesses the application and AirMedia device.

To download the guest application from the **AirMedia** device, complete the steps below.

On an AirMedia 2.0 device:

1. Open a web browser and enter the AirMedia device's IP address or hostname into the browser.
2. Click **Start Presenting**.



3. Click the **Mac** button to download the Mac AirMedia software.

#### AirMedia Download Screen for AM-200, AM-300, DMPS3, and CCS-UC-1

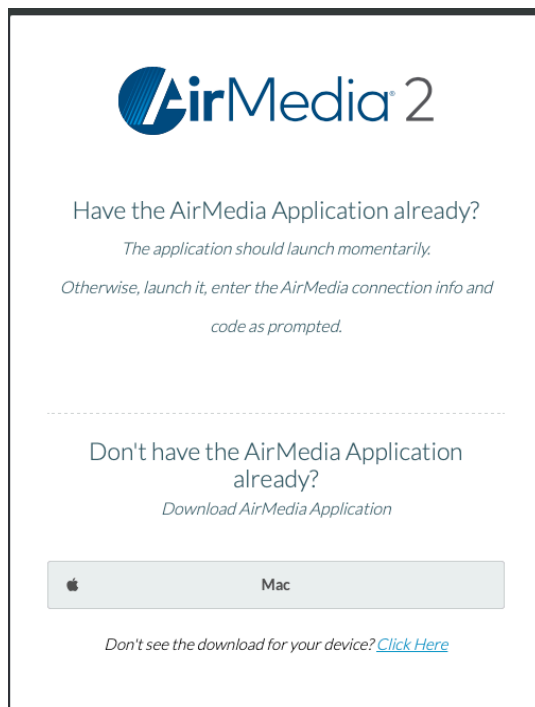

On an AM-100 or AM-101:

1. Open a web browser and enter the AirMedia device's IP address or hostname into the browser.
2. Click the Download button next to **Client for Mac®**

## AirMedia Download Screen for AM-100 and AM-101

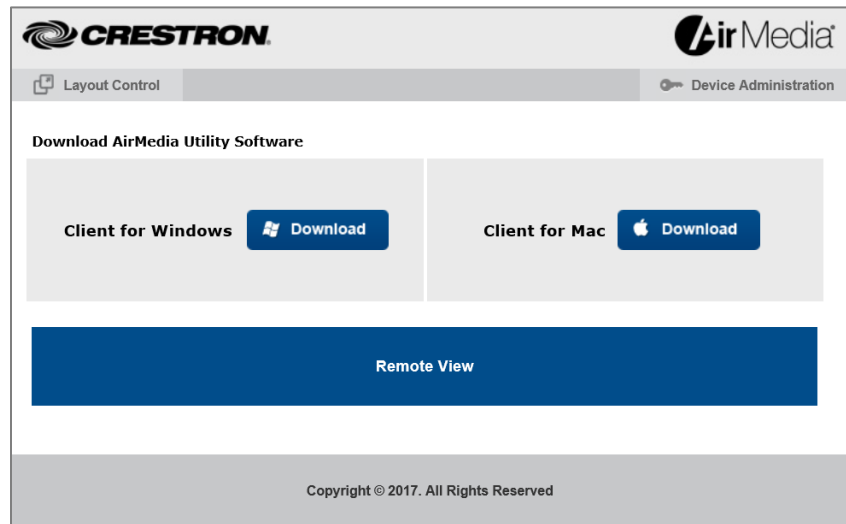

Install the application:

1. Run the application.
2. If prompted, enter the login code as shown on the connected display.
  - If connecting to an AM-100 that is connected to a configured Crestron Connected display, the display will turn on automatically, and the presentation session begins.
  - If the device is an AirMedia 2.0 device, or an AM-101 in mirroring mode, a dialog box is displayed, showing guidance on using the native mirroring function that is built into macOS. Follow the directions to begin the presentation session. If a Crestron Connected display is connected and configured for operation, the display turns on automatically during the process.

### AirPlay® Software Guidance Dialog Box

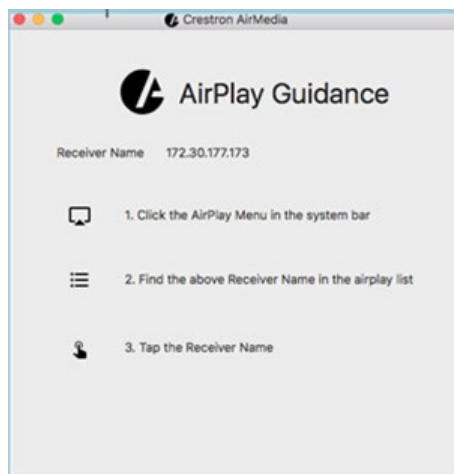

---

**NOTE:** Only one macOS or iOS device using the native mirroring function can be connected at a time to an AirMedia device. If any other sender connects to the AirMedia device, the last connected device will be disconnected and the connection procedure will need to be repeated

**NOTE:** The guest application for macOS can also be downloaded from [present.crestron.com](http://present.crestron.com) and distributed to websites or other media for users to download. The guest application can be distributed with the connection parameters embedded in the file name so the user only has to enter the login code (if required).

The supported formats are:

<any\_text>\_<ip\_address>.dmg

<any\_text><ip\_address>.dmg

The underscore and dot must precede the IP address, for example:  
executive\_conference\_room\_10.1.1.13.dmg.

---

## Airmedia Deployable Application

The deployable application shows the user a list of devices on the **Connect** dialog box. The user can select a device for connection or search for a device within a longer list of devices.

To connect to a device, perform the following procedure.

1. Launch AirMedia. The Connect dialog box is displayed. The **Connect** dialog box on macOS is inherently different from the Windows user interface, as shown below.

### Connect Dialog Box

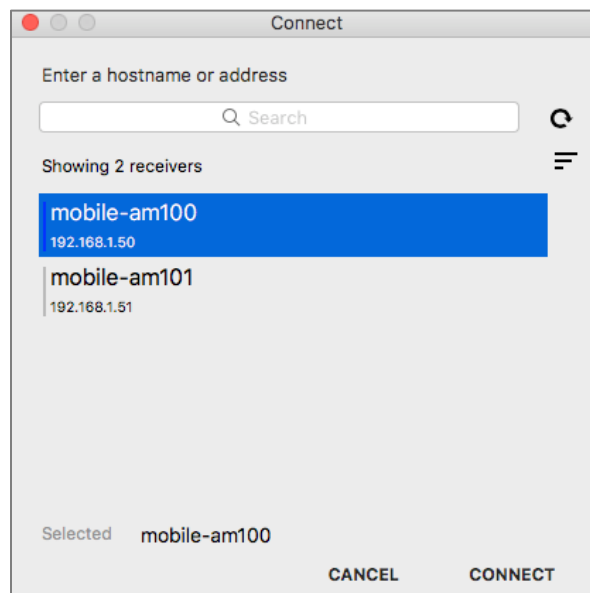

2. From the **Connect** screen, select a gateway from the list.

3. Click **Connect**. If prompted, enter the passcode as shown on the connected display.
  - If the device is an AirMedia 2.0 device, or an AM-101 in mirroring mode, a dialog box is displayed, showing guidance on using the native mirroring function that is built into macOS. Follow the directions to begin the presentation session. If a Crestron Connected display is connected and configured for operation, the display turns on automatically during the process.

#### Crestron AirMedia AirPlay Guidance Dialog Box

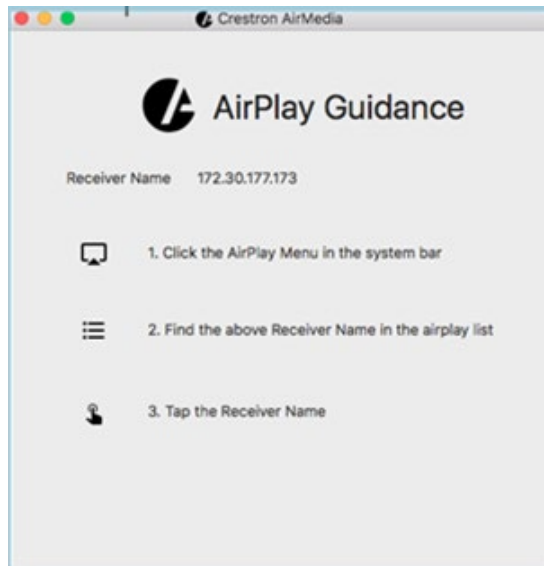

---

**NOTE:** Only one macOS or iOS device using the native mirroring function can be connected at a time to an AirMedia device. If any other sender connects to the AirMedia device, the last connected device will be disconnected and the connection procedure will need to be repeated.

---

- If connecting to an AM-100 that is connected to a configured Crestron Connected display, the display will turn on automatically, and the presentation session begins.

---

**NOTE:** When using the moderator functions of an AM-100 or AM-101, the user name that appears to the moderator can be set in the Preferences menu. The default username is the same username as the active user logged into macOS.

---

## User Experience with Chrome OS

Crestron has developed an AirMedia extension for the Google Chrome web browser specifically for mirroring from Chrome OS devices. This is supported with the AM-200, AM-300, and CCS-UC-1.

**NOTE:** The AirMedia extension for the Google Chrome web browser is intended for screen sharing from a Chrome OS device. On other platforms such as Windows and Mac, this is not recommended.

The AirMedia Extension for Google Chrome relies on web technologies for screen sharing that are built-in to the web browser. Performance variations with motion video (quality and frame rate) may occur based upon the encoding capabilities of the Chrome OS device and the nature of the content being displayed (i.e., high motion video).

### Install the AirMedia extension for Google Chrome

1. Visit the chrome web store using the following link:

<https://chrome.google.com/webstore/detail/airmedia-sender/ljophmlbljinjodcbogmdogcpclifepk>

2. Click **Add to Chrome**

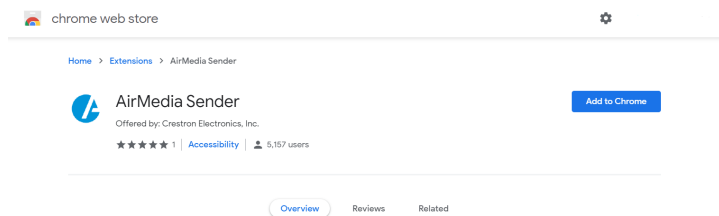

3. Click **Add extension**

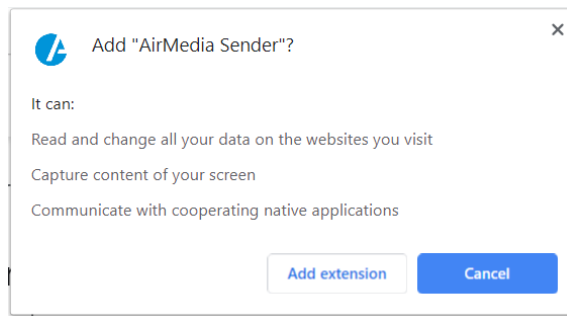

### Connect

1. Click the AirMedia icon  in the top right corner of the Chrome browser.
2. Enter the IP Address or Hostname of the AirMedia receiver.

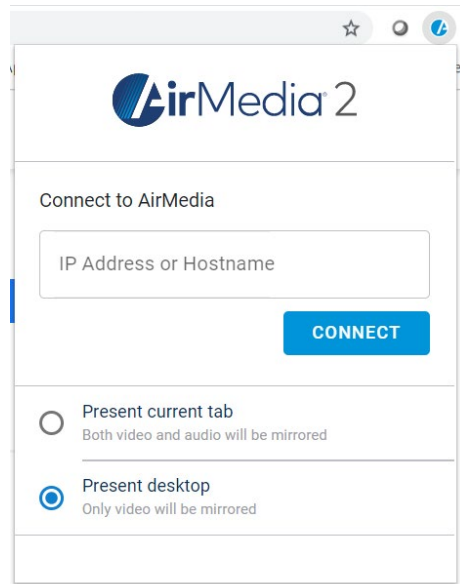

3. Click the radio button next to **Present current tab** in the web browser to mirror only the current web browser tab (with audio) or click the radio button next to **Present desktop** to mirror the whole screen (without audio).
4. Click **Connect**.

## Miracast on AirMedia 2.0

Miracast is supported on AirMedia 2.0 products, specifically the CCS-UC-1 and the AM-200/300 (future firmware release). Miracast is a mirroring protocol and wireless technology used to project your screen to the AirMedia 2.0 receiver without the need to install an application on your PC.

### Required Wireless Adaptor

Miracast on AirMedia 2.0 requires the addition of the AM-USB-WIFI AirMedia WiFi USB Adaptor (sold separately). There are two iterations of this adaptor available:

- AM-USB-WIFI (Sold in the United States)
- AM-USB-WIFI-I (Sold Internationally)

Both versions of the adaptor support 802.1A/B/G/N/AC wireless networking standards on both the 2.4GHz and 5GHz frequencies.

The difference between the US and International Model is the supported Wi-Fi channels.

*World*

*2G Channels : 1, 2, 3, 4, 5, 6, 7, 8, 9, 10, 11, 12, 13*

*5G channels: 36, 40, 44, 48, 149, 153, 157, 161, 165*

US

2G Channels: 1, 2, 3, 4, 5, 6, 7, 8, 9, 10, 11

5G Channels: 36, 40, 44, 48, 149, 153, 157, 161, 165

## Miracast Behavior – How it Works

Users connect to a Miracast receiver using the Windows connect menu. The Windows connect menu can be accessed via the Windows notification center or using the shortcut  (Windows) + K. On touch capable Windows 10 devices, swipe in from the right edge of the screen.

Miracast connection has two phases: the discovery phase and the connection phase. The discovery phase uses Wi-Fi based discovery. For this reason, the AirMedia Wi-Fi USB Adaptor is required for Miracast functionality.

After the list of Miracast receivers is discovered, the user will select a device from the list to connect to. Windows 10 will first connect to the Miracast receiver via the existing infrastructure. This is done by resolving the hostname through mDNS, then connecting to the receiver over the infrastructure. If the hostname can't be resolved or the connection over infrastructure fails, Windows 10 will then fall back to establishing the Miracast session using the standard Wi-Fi Direct® connection. Wi-Fi Direct is a peer-to-peer connection that establishes a private network between the user device and the receiver. The private peer-to-peer network coexists with the user's other network connections. Once the network is established, Windows 10 will then establish connections over the peer-to-peer network. This two-fold connection mechanism is useful for guest users who may not be connected to the same network.

## Supported Miracast Devices



Crestron recommends Windows 10 devices with version 1809 or newer. Versions 1703 and onwards may work, but with limited or partial functionality. The PIN code to authenticate the AirMedia session is not supported for infrastructure connection on versions prior to 1809. Miracast from Android OS devices are not officially supported. Connection of Miracast over Wi-Fi Direct may produce mixed results. Other limitations may exist.

## Considerations for Deploying and Commissioning Miracast for AirMedia 2.0 Devices

- For optimal performance, the network switch that the AirMedia receiver connects to must have a sufficient buffer size (>2.5Mb per CCS-UC-1 or AM-200/300 device attached to that switch). This is because both the CCS-UC-1 and AM-200/300 have 10/100 based LAN ports. In most cases, switches and routers are configured for best-effort packet forwarding. This means that the router forwards all packets it receives to the best of its ability. Everything typically functions with best-effort forwarding until an interface is oversubscribed. Once that happens, even if the oversubscription is momentary, the router must queue packets to avoid dropping them. Therefore, the amount of queuing available on an interface determines the amount of momentary oversubscription that the router can tolerate on that interface without dropping packets and causing performance degradation.
- Miracast Wi-Fi Direct requires a PIN code to be set. For this reason, the CCS-UC-1 and AM-200/300 will not allow you to disable the login PIN code if Wi-Fi Direct is enabled.

- When commissioning the device and adjusting the login code mode (enabled/disabled/changed), the device may not initially recognize the change. Within a few minutes, the change will be reflected.

## Troubleshooting Miracast Connection Issues

- Ensure the Wi-Fi adaptor is enabled on the client device and that the latest drivers are installed for that adaptor.
- Ensure the network is not blocking any of the Miracast related ports listed on page 14 (7236, 7250).
- Ensure the network is not blocking the mDNS discovery port list on page 14 (5353)
- Check for Miracast support on the client device:
  1. Press  (Windows) + R and type **dxdiag**.
  2. Click **Save All information...**
  3. Open the saved DxDiag.txt and find Miracast. It should say **Available, with HDCP**.
- Check the firewall on the client device:
  1. Disable the firewall and test projection. If Miracast works with the firewall disabled, add an exception for  
C:\Windows\System32\WUDFHost.exe  
  
Allow In/Out connections for TCP and UDP, Ports: All.
- Check the group policy settings on the client device. On domain-joined devices, Group Policy can also block Miracast.
  1. Use the  (Windows) + R and type **rsop.msc** to execute the Resultant Set of Policy snap-in. This will show the current policies applied to the PC.
  2. Review **Computer Configuration > Windows Settings > Security Settings > Wireless Network (IEEE 802.11) Policies**. There should be a setting for wireless policies.
  3. Double click the setting for wireless policies and a dialog box will appear.
  4. Open the Network Permissions tab and select **Allow everyone to create all user profiles**.

# AirMedia Apps

The AirMedia apps for iOS and Android are the primary way for mobile and tablet devices to connect to AirMedia Presentation Gateways.

## AirMedia App for iOS Devices

This app is designed for iPhone® and iPad® devices. For information on the AirMedia app for iOS devices, refer to <https://itunes.apple.com/us/app/crestron-airmedia/id685412055>.

This app is only available for download from the App Store for iOS devices. The download may also be accessed through the AirMedia landing page by typing the AirMedia enabled device's IP address into a web browser. If connection to an AM-100 is attempted from this app, the AirMedia for AM-100 app will be launched or, if not installed, the user will be directed to the app store to install this app.

## AirMedia for AM-100 App for iOS Devices

This app is designed for iPhone® and iPad® devices connecting to AM-100 AirMedia Presentation Gateways, as well as the AM-101 when using moderator mode or quad view. For information on the AirMedia app for iOS devices, refer to <https://itunes.apple.com/us/app/crestron-airmedia-for-am-100/id1310847514>.

This app is only available for download from the App Store for iOS devices and does not provide full-screen mirroring. Documents are rendered within the app, and control for other functions relating to moderation are also contained within the app.

## AirMedia App for Android Devices

This app is designed for Android devices. For information on the AirMedia app for Android devices, refer to <https://play.google.com/store/apps/details?id=com.crestron.airmedia>.

The download may also be accessed through the AirMedia landing page by typing the AirMedia enabled device's IP address into a web browser.

## AirMedia for AM-100 App for Android Devices

This app is designed for Android devices connecting to AM-100 AirMedia Presentation Gateways, as well as the AM-101 when using moderator related functions. For information on the AirMedia for AM-100 app for Android devices, refer to <https://play.google.com/store/apps/details?id=com.crestron.legacy.airmedia>.

This app is only available to download from the Google Play store for Android devices and does not provide full-screen mirroring. Documents are rendered within the app, and control for other functions relating to moderation are also contained within the app. If connection to an AirMedia 2.0 Presentation Gateway is attempted using this app, the app will fail to connect.

## Connect to AirMedia Devices with Mobile Applications

AirMedia applications connect to AirMedia devices by discovering them or by manually entering the IP address or hostname of the device.

Connected devices are saved to allow for easier future connection. A search function provides quick navigation of long lists. Frequently used AirMedia devices can be marked as favorites for quick connections.

AirMedia app connection screens are shown below.

AirMedia for iOS and Android

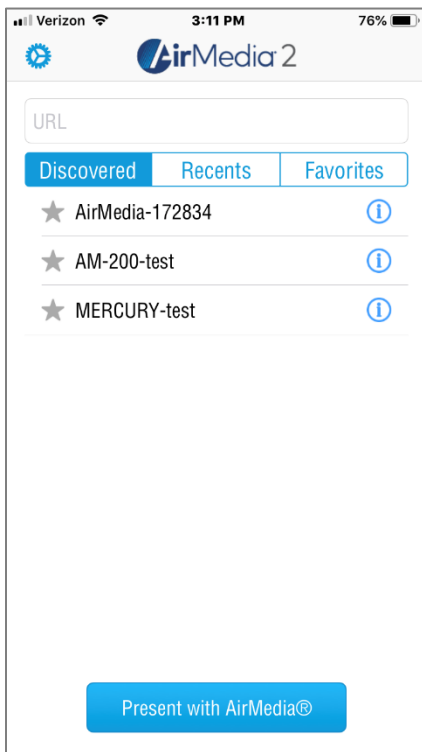

AirMedia for AM-100 on iOS and Android

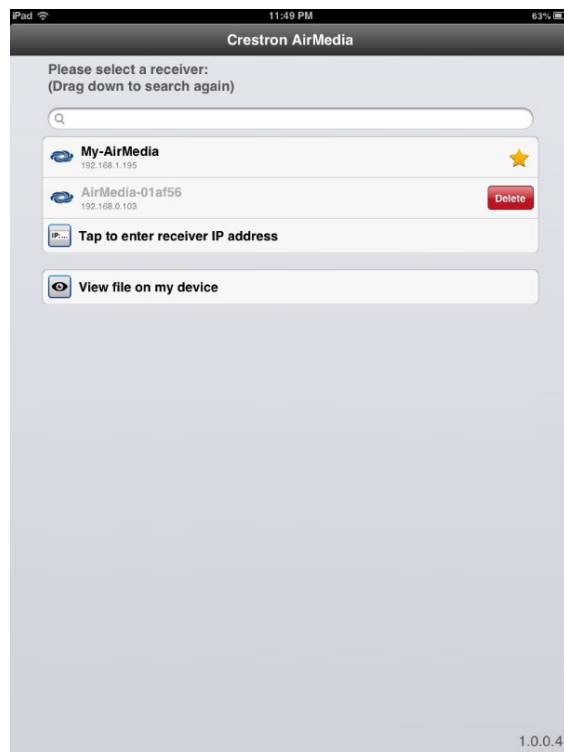

Since the iOS application uses the built-in iOS device mirroring feature, the application will not connect directly to the AirMedia Presentation Gateway after the "Present with AirMedia" button is pressed. Instead, the application instructs the user to use the native device mirroring function in the iOS Control Center, where a list of devices will be presented. Once a device is selected, a prompt for a password is shown (if the four-digit code is required by the device). Upon completion of these steps, the iOS device starts sharing content to the AirMedia device as shown in the following diagrams.

### Connect with iOS App

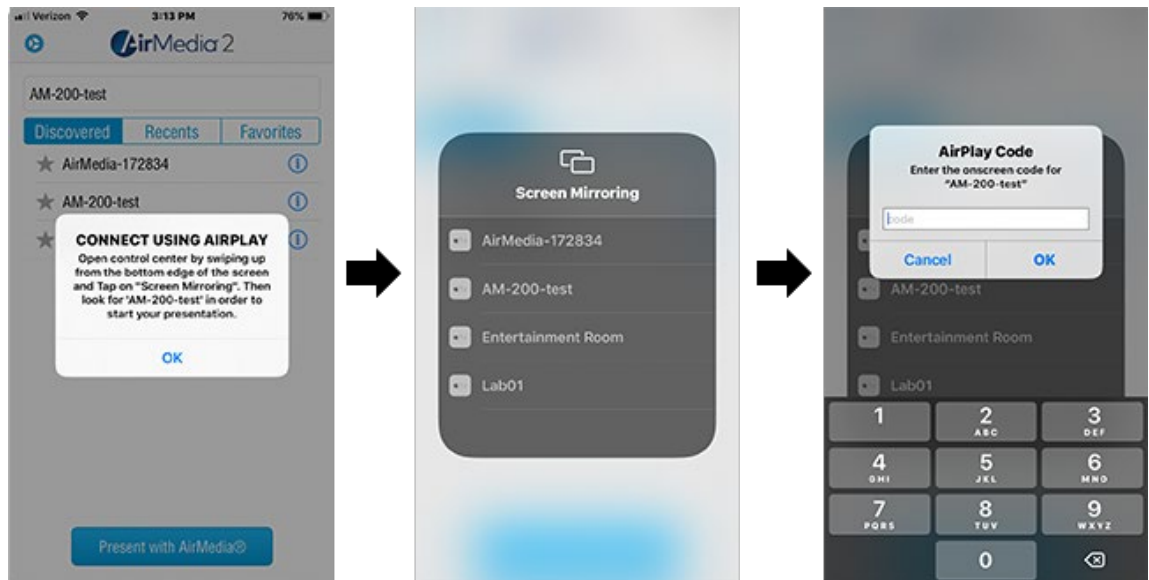

## Video Push

iOS apps for video streaming employ an alternate mode for playing videos on AirMedia 2.0 devices called Video Push. When using these apps, video plays directly on the AirMedia Presentation Gateway rather than on the device. The app may provide controls in the area of the app where the video would normally be played. This mode assists the iOS device in saving battery life as well as utilizing the wired portion of the network to further enhance playback reliability.

## App Controls for Streaming Content



---

## NOTES:

- Video streaming from third party apps may not work correctly on AM-101.
  - Video streaming apps may occasionally change the way they interact with iOS device mirroring that interferes with the correct operation of playback mode. When such compatibility breaks, the video streaming app must be updated to restore correct functionality.
  - Video Push requires the sender and receiver to be on the same subnet.
-

# Test and Commission the AirMedia Presentation System

Once AirMedia devices are selected and deployed in a properly provisioned network, and PC applications and mobile apps are configured, the AirMedia Presentation System for each room should be tested prior to commissioning of the device. The following information and guidelines are provided as assistance in considerations for testing.

## AirMedia Test Use Cases by User Experience

When testing AirMedia, use cases are typically split in priority as follows:

- Desktop users
- Mobile users

Testing the entire flow of the desktop and mobile AirMedia experiences helps ensure that mass deployment works effectively.

### Front of Room Experience

All AirMedia use cases center around the user's ability to access the AirMedia device through the front-of-room experience screen. The front-of-room experience is provided by PinPoint UX in AirMedia 2.0 devices, and by the legacy front-of-room experience in the AM-100 and AM-101. Each AirMedia device can display connection information and customizable backgrounds.

In simpler rooms such as huddle spaces, PinPoint UX is the default and should be used in every case. Simpler rooms are typically where the only devices for presentation are the AM-200, AM-300 or CCS-UC-1, along with any attached sensors, switches and panels. For more complex configurations where simpler AirMedia devices are attached to (i.e., DMPS3-4K-250-C, DMPS3-4K-350-C, and other Crestron products that have large numbers of inputs and/or use programming via control processors), it is important to program and control the system so that the default front-of-room experience is set for PinPoint UX.

There are some cases that do not allow PinPoint UX to be the default front-of-room experience. In these cases, clear instructions for accessing the AirMedia and PinPoint UX screen or the AirMedia connection information (such as address and code for room) should be provided to users. Whenever controls such as buttons or panels are present, they should be clearly labeled and highly visible so users can access AirMedia.

The customizable background feature is an effective way to give guidance to all AirMedia users in any room and should be leveraged whenever possible. On AirMedia 2.0 devices, there are additional options for the connection address, including a "Custom" option that allows for entry of something other than the IP address or host name of the device. This can also be set to text instructions, URL shortening services, or anything else an administrator may need to help the user connection experience.

## PC User Experience Test Case Considerations

PC users typically comprise 85-90% of the total types of users, with mobile users taking up the remainder. The user experience will vary in environments with mixed Windows and macOS PCs. Instructions for application use vary as discussed in "PC Sender Applications" on page 29. To provide an optimal AirMedia user experience:

- Install the AirMedia deployable sender application silently with the appropriate options for operation. Application management from a central organization can also provide a uniform user experience over having individual users install the application.
- Provide basic guidance to users through the front-of-room experience. Instructive, on-screen backgrounds or instruction placards can also be provided to advise users on proper use.
- Provide optimal methods for room discovery, such as centralized room lists and allowing mDNS and Bonjour (including third-party solutions).
- Design user interfaces (i.e., panels or buttons) for clarity to enable ease of use when first connecting to AirMedia.

Testing all of the intended connection methods prior to commissioning a system will help ensure a smooth user experience.

## Mobile User Experience Test Case Considerations

Mobile users comprise a smaller, but important portion of AirMedia users in many environments. Up to 15% of mobile users, typically using either Android or iOS devices will use AirMedia from their mobile devices. While the same considerations for PC users can apply to mobile users, special considerations for mobile users include the following:

- Installation of the AirMedia app typically requires users access the respective app store for the device and cannot be automated, so guidance will need to be given.
- The AirMedia app allows users full-screen capture for AM-101 and AirMedia 2.0 devices.
- The AirMedia for AM-100 app is primarily for AM-100 (or AM-101) users or those who require multiview and moderator mode functions. The AirMedia for AM-100 app will launch automatically from the AirMedia app (if installed) when an attempt is made to connect to the AM-100. If the correct app is not installed, the user will be directed to the corresponding app store to download the correct application.
- While the iOS and Android AirMedia applications have similar user interfaces, the iOS experience requires use of iOS' built-in mirroring function. Instructions for use are given to the user upon tapping the **Present with AirMedia** button.

- Room lists are not available on AirMedia mobile apps. The AirMedia and PinPoint apps, however, do have the capability to use Bluetooth beacons such as the Crestron PP-100 provisioned through Crestron Fusion to automatically present room connection information. Refer to the Crestron Fusion and Crestron PP-100 product documentation for details on configuring Bluetooth room beacons.
- Although streaming apps for popular video services are supported in AirMedia, the AirMedia device must be on the same subnet as the mobile device to function correctly. These apps may occasionally exhibit erratic behavior on mobile devices when the app is updated. It is recommended to contact the app vendor in the event such behavior persists.

As with PC users, testing for mobile users should encompass the considerations above for both the AirMedia app and the AirMedia for AM-100 app.

## Commission and Monitor AirMedia Devices

Once the use cases for AirMedia are established and tested, and other room functionality is tested, the commissioned room is ready for AirMedia and other uses. For optimum performance, AirMedia use cases should be reevaluated as time and circumstance permits. Crestron provides cloud tools such as Crestron Fusion and Crestron XIO Cloud Service to understand how AirMedia-enabled rooms are used. Analyzing usage information and patterns can help adjust rooms to user needs for AirMedia, while monitoring tools can minimize downtime and user complaints should an issue arise. These monitoring tools should be used in conjunction with network monitoring wherever possible to determine issues with Wi-Fi access points and the general health of the network.

This page is intentionally left blank.

---

**Crestron Electronics, Inc.**  
15 Volvo Drive, Rockleigh, NJ 07647  
Tel: 888.CRESTRON  
Fax: 201.767.7576  
[www.crestron.com](http://www.crestron.com)



**Deployment Guide – DOC. 7693L**  
**(2041620)**

**11.19**

Specifications subject to  
change without notice.