

visual engineering
LIGHTWARE

User's Manual



UCX-4x2-HC30
UCX-4x2-HC30D

Universal Switcher

Important Safety Instructions

Class II apparatus construction.

The equipment should be operated only from the power source indicated on the product.

To disconnect the equipment safely from power, remove the power cord from the rear of the equipment, or from the power source. The MAINS plug is used as the disconnect device, the disconnect device shall remain readily operable.

There are no user-serviceable parts inside of the unit. Removal of the cover will expose dangerous voltages. To avoid personal injury, do not remove the cover. Do not operate the unit without the cover installed.

The appliance must be safely connected to multimedia systems. Follow instructions described in this manual.

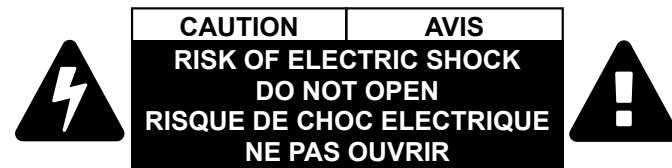

Ventilation

For the correct ventilation and to avoid overheating ensure enough free space around the appliance. Do not cover the appliance, let the ventilation holes free and never block or bypass the ventilators (if any).

WARNING

To prevent injury, the apparatus is recommended to securely attach to the floor/wall or mount in accordance with the installation instructions. The apparatus shall not be exposed to dripping or splashing and that no objects filled with liquids, such as vases, shall be placed on the apparatus. No naked flame sources, such as lighted candles, should be placed on the apparatus.

Waste Electrical & Electronic Equipment WEEE

This marking shown on the product or its literature, indicates that it should not be disposed with other household wastes at the end of its working life. To prevent possible harm to the environment or human health from uncontrolled waste disposal, please separate this from other types of wastes and recycle it responsibly to promote the sustainable reuse of material resources. Household users should contact either the retailer where they purchased this product, or their local government office, for details of where and how they can take this item for environmentally safe recycling. Business users should contact their supplier and check the terms and conditions of the purchase contract. This product should not be mixed with other commercial wastes for disposal.

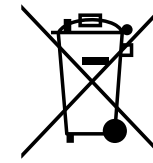

Common Safety Symbols

Symbol	Description
	Direct current
	Alternating current
	Double insulation
	Caution, possibility of electric shock
	Caution

Symbol Legend

The following symbols and markings are used in the document:

WARNING! Safety-related information which is highly recommended to read and keep in every case!

ATTENTION! Useful information to perform a successful procedure; it is recommended to read.

DIFFERENCE: Feature or function that is available with a specific firmware/hardware version or product variant.

INFO: A notice which may contain additional information. Procedure can be successful without reading it.

DEFINITION: The short description of a feature or a function.

TIPS AND TRICKS: Ideas which you may have not known yet but can be useful.

Navigation Buttons

 Go back to the previous page. If you clicked on a link previously, you can go back to the source page by pressing the button.

 Navigate to the Table of Contents.

 Step back one page.

 Step forward to the next page.

Document Information

All presented functions refer to the indicated products. The descriptions have been made during testing these functions in accordance with the indicated Hardware/Firmware/Software environment:

Item	Version
Lightware Device Controller (LDC) software	2.5.4b3
Lightware Device Updater V2 (LDU2) software	2.8.0
Firmware package	1.1.0b7
Hardware	2.2

Document revision: 1.4

Release date: 04-05-2020

Editor: Judit Barsony

About Printing

Lightware Visual Engineering supports green technologies and Eco-friendly mentality. Thus, this document is made for digital usage primarily. If you need to print out few pages for any reason, follow the recommended printing settings:

- Page size: A4
- Output size: Fit to page or Match page size
- Orientation: Landscape

TIPS AND TRICKS: Thanks to the size of the original page, a border around the content (gray on the second picture below) makes possible to organize the pages better. After punching the printed pages, they can be placed easily into a ring folder.

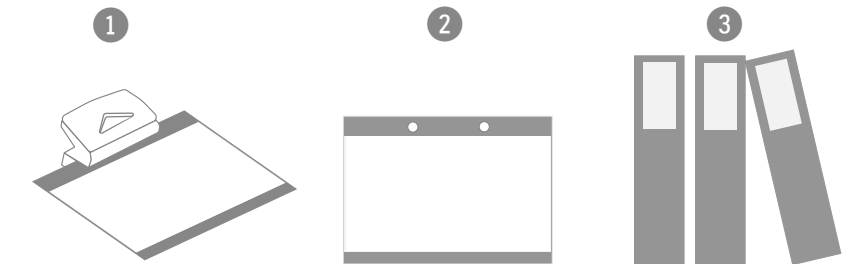

Hashtag (#) Keywords in the Document

This user's manual contains keywords with hashtag (#) to help you to find the relevant information as quick as possible.

The format of the keywords is the following:

#<keyword>

The usage of the keywords: use the **Search** function (Ctrl+F / Cmd+F) of your PDF reader application, type the # (hashtag) character and the wished keyword.

The special keyword indicates a new feature/function that has just appeared in the latest firmware or software version.

Example

#dhcp

This keyword is placed at the DHCP setting command in the LW3 Programmer's reference section.

Table of Contents

1. INTRODUCTION	6	5.3. VIDEO INTERFACE	27	7. LW3 PROGRAMMERS' REFERENCE	58
1.1. DESCRIPTION	7	5.3.1. DisplayPort Alternate Mode.....	27	7.1. OVERVIEW	59
1.2. BOX CONTENTS	7	5.3.2. DisplayPort Alternate Mode and USB 3.x Mixed	28	7.2. INSTRUCTIONS FOR THE TERMINAL APPLICATION USAGE	59
1.3. OPTIONAL ACCESSORIES	7	5.4. THE AUTOSELECT FEATURE	28	7.3. PROTOCOL RULES	59
1.4. FEATURES OF THE DEVICE.....	8	5.5. AUDIO INTERFACE	31	7.3.1. LW3 Tree Structure and Command Structure (examples).....	59
1.5. TYPICAL APPLICATION	9	5.5.1. Analog Audio Interface	31	7.3.2. General Rules.....	59
2. PRODUCT OVERVIEW	10	5.5.2. Dante® Audio Interface.....	32	7.3.3. Legend for the Control Commands.....	60
2.1. FRONT VIEW.....	11	5.6. ETHERNET INTERFACE	33	7.3.4. Command Types	60
2.2. REAR VIEW.....	11	6. SOFTWARE CONTROL - LIGHTWARE DEVICE CONTROLLER	35	7.3.5. Prefix Summary	61
3. FRONT PANEL CONTROL	12	6.1. INSTALL AND UPGRADE	36	7.3.6. Error Messages	61
3.1. BUTTON FUNCTIONALITY	13	6.2. RUNNING THE LDC	36	7.3.7. Escaping	61
3.1.1. Video Source Selection	13	6.3. ESTABLISHING THE CONNECTION	37	7.3.8. Signature.....	61
3.1.2. Reset to Factory Default Settings.....	13	6.4. LDC LAYOUT	38	7.3.9. Subscription.....	61
3.2. STATUS LEDs	13	6.5. VIDEO & AUDIO CROSSPOINT	39	7.3.10. Notifications about the Changes of the Properties	62
3.2.1. Front Panel LEDs	13	6.5.1. Port Tiles.....	40	7.4. SYSTEM COMMANDS	63
3.2.2. Rear Panel LEDs	13	6.6. PORT PROPERTIES WINDOW	41	7.4.1. Set the Device Label.....	63
3.2.3. Ethernet Status LEDs	14	6.6.1. Welcome Screen.....	41	7.4.2. Reset the Device.....	63
3.2.4. Dante® Audio Out (in UCX-4x2-HC30D model)	14	6.6.2. USB-C Inputs.....	42	7.4.3. Restore the Factory Default Settings	63
4. INSTALLATION	15	6.6.3. HDMI Video Input	44	7.4.4. Querying the Firmware Package Version.....	63
4.1. MOUNTING OPTIONS	16	6.6.4. HDMI Video Output	45	7.4.5. Control Lock.....	63
4.1.1. 1U High Rack Shelf.....	16	6.6.5. Embedded Audio Input.....	46	7.4.6. Set Current Time.....	63
4.1.2. Mounting the Device (with optionally available accessories)	16	6.6.6. Analog Audio Output.....	47	7.5. VIDEO PORT SETTINGS - GENERAL	64
4.1.3. Ventillation.....	17	6.6.7. Frame Detector	47	7.5.1. Switch Video Input	64
4.2. ELECTRICAL CONNECTIONS.....	18	6.7. USB CROSSPOINT	48	7.5.2. Switch an Input to All Outputs	64
4.2.1. HDMI Input and Output Ports	18	6.7.1. USB-C Port Properties	48	7.5.3. Lock the Video Port.....	64
4.2.2. USB Connectors	18	6.7.2. USB-B Port Properties	49	7.5.4. Mute the Video Port	64
4.2.3. Analog Stereo Audio	18	6.8. EDID MENU	51	7.5.5. Set the Autoselect Policy	65
4.2.4. Secure Control LAN, Utility AV LAN, Configurable Ethernet Port	18	6.8.1. EDID Operations	51	7.5.6. Change the Autoselect Included Input Ports.....	65
4.2.5. OCS Connector	19	6.8.2. EDID Summary Window	52	7.5.7. Change the Input Port Priority	65
4.2.6. GPIO - General Purpose Input/Output Ports.....	19	6.8.3. Editing an EDID	52	7.5.8. Query the Connected Source	65
4.3. POWERING OPTIONS	20	6.8.4. Creating an EDID - Easy EDID Creator	53	7.5.9. Query the Connected Destinations.....	66
4.4. POWER DELIVERY.....	20	6.9. CONTROL MENU	53	7.5.10. Query the Input Switchable Ability	66
4.4.1. Power Data Objects (USB-C).....	21	6.10. ETHERNET	53	7.5.11. SignalPresent	66
4.5. USB-C CABLE RECOMMENDATION.....	21	6.10.1. GPIO	54	7.5.12. HDCP Setting (Input Port).....	66
4.6. CONNECTING STEPS.....	22	6.10.2. OCS - Occupancy Sensor	54	7.5.13. HdcpMode	66
5. DEVICE CONCEPT	23	6.11. SETTINGS MENU	55	7.5.14. EmbeddedAudioPresent.....	67
5.1. UNIVERSAL SWITCHER CONCEPT	24	6.11.1. Status.....	55	7.5.15. EmbeddedAudioMute	67
5.2. USB INTERFACE	24	6.11.2. Network.....	55	7.5.16. OutputSignalType	67
5.2.1. USB-C Interface	24	6.11.3. System	56	7.5.17. Output5VMode	67
5.2.2. USB Data - USB 3.1 Gen1 Interface	25	6.12. ADVANCED VIEW WINDOW	57		
5.2.3. USB Service Ports - USB 2.0 Interface	26				

7.6. WELCOME SCREEN SETTINGS	68	7.11. EDID MANAGEMENT	76	10. TECHNOLOGIES	92
7.6.1. Display Welcome Screen Image.....	68	7.11.1. Query the Emulated EDIDs.....	76	10.1. EDID MANAGEMENT	93
7.6.2. Display Welcome Screen Text	68	7.11.2. Query the Validity of a Dynamic EDID	76	10.1.1. Understanding the EDID.....	93
7.6.3. Set Welcome Screen Text	68	7.11.3. Query the Preferred Resolution of a User EDID	76	10.1.2. Advanced EDID Management.....	93
7.6.4. Reset Welcome Screen Image.....	68	7.11.4. Emulating an EDID to an Input Port.....	76	10.2. HDCP MANAGEMENT	94
7.7. VIDEO PORT SETTINGS - USB-C RELATED COMMANDS	68	7.11.5. Emulating an EDID to All Input Ports	76	10.2.1. Protected and Unprotected Content	94
7.7.1. Restart Link Training	68	7.11.6. Copy an EDID to User Memory	77	10.2.2. Disable Unnecessary Encryption.....	94
7.8. AUDIO PORT SETTINGS	68	7.11.7. Deleting an EDID from User Memory	77	10.2.3. HDCP v2.2.....	95
7.8.1. Switch Audio Input	68	7.11.8. Resetting the Emulated EDIDs.....	77	10.3. PIXEL ACCURATE RECLOCKING	96
7.8.2. Query the Connected Source.....	69	7.12. ETHERNET PORT CONFIGURATION	78	11. APPENDIX	97
7.8.3. Query the Connected Destinations.....	69	7.12.1. Set the DHCP State	78	11.1. SPECIFICATIONS	98
7.8.4. Set Autoselect Operation Mode	69	7.12.2. Change the IP Address (Static)	78	11.2. PORT NUMBERING	99
7.8.5. Set the Followed Video Port to Autoselect.....	69	7.12.3. Change the Subnet Mask (Static)	78	11.3. FACTORY EDID LIST	100
7.8.6. Lock the Audio Port.....	69	7.12.4. Change the Gateway Address (Static).....	78	11.4. CABLE WIRING GUIDE	101
7.8.7. Mute the Audio Port 1.	69	7.12.5. Apply Network Settings	78	11.4.1. Audio Ports	101
7.8.8. Mute the Audio Port 2.	70	7.13. GPIO PORT CONFIGURATION	79	11.5. MECHANICAL DRAWINGS	102
7.8.9. Query the Audio Signal Presence	70	7.13.1. Querying the Direction of a GPIO Pin	79	11.6. FACTORY DEFAULT SETTINGS	104
7.8.10. Analog Audio Output Volume (dB) Setting	70	7.13.2. Setting the Direction of a GPIO Pin	79	11.7. APPLIED PORTS (NETWORK SETTINGS)	104
7.8.11. Analog Audio Output Volume Percent Setting	70	7.13.3. Querying the Output Level of a GPIO Pin	79	11.8. FIRMWARE RELEASE NOTES	105
7.8.12. Setting the Balance	70	7.13.4. Setting the Output Level of a GPIO Pin	79	11.9. HASHTAG KEYWORD LIST	107
7.8.13. Analog Audio Output Level Settings by Steps (dB).....	71	7.13.5. Setting the Output Level for a Specified Time.....	79	11.10. FURTHER INFORMATION	108
7.8.14. Analog Audio Output Level Settings by Steps in Percent.....	71	7.13.6. Toggling the Level of a GPIO Pin.....	79		
7.8.15. Analog Audio Output Balance by Steps	71	7.14. OCS PORT CONFIGURATION	80		
7.9. USB PORT SETTINGS	71	7.14.1. Querying the Input Level of an OCS Pin	80		
7.9.1. Switch USB Input	71	7.14.2. Set the Sensor Type	80		
7.9.2. Query the Connected Source.....	71	7.14.3. Querying the Reported OCS State.....	80		
7.9.3. Query the Connected Destinations.....	72	7.15. LW3 COMMANDS - QUICK SUMMARY	81		
7.9.4. Lock the USB Port	72	8. FIRMWARE UPGRADE	84		
7.9.5. Setting the 5V Sending to the USB Peripherals	72	8.1. INTRODUCTION	85		
7.9.6. Set the USB Autoselect Policy.....	73	8.2. PREPARATION	85		
7.9.7. Set the Followed Video Port to Autoselect.....	73	8.2.1. About the Firmware Package (LFP2 File)	85		
7.9.8. Change the Autoselect Included USB Ports	73	8.2.2. LDU2 Installation	85		
7.9.9. Change the USB Port Priority.....	73	8.3. RUNNING THE SOFTWARE	86		
7.10. USB PORT SETTINGS - USB-C RELATED COMMANDS	74	8.4. THE UPGRADING STEPS	87		
7.10.1. Set USB-C Power	74	8.5. IF THE UPGRADE IS NOT SUCCESSFUL	88		
7.10.2. Set Displayport Alternate Mode Policy	74	9. TROUBLESHOOTING	89		
7.10.3. Query the Host Alternate Mode Support	74	9.1. USE CASE STUDIES	90		
7.10.4. Query the Status of the Alternate Mode	74	9.2. HOW TO SPEED UP THE TROUBLESHOOTING PROCESS?	91		
7.10.5. Query the Port Data Role	75				
7.10.6. Query the Port Power Role.....	75				
7.10.7. Set Port Power Role.....	75				

1

Introduction

Thank you for choosing Lightware's The Taurus UCX-series devices. In the first chapter we would like to introduce the device highlighting the most important features in the below listed sections:

- ▶ DESCRIPTION
- ▶ BOX CONTENTS
- ▶ OPTIONAL ACCESSORIES
- ▶ FEATURES OF THE DEVICE
- ▶ TYPICAL APPLICATION

1.1. Description

Lightware's universal switcher enhances and extends the possibilities of a meeting room and allows meeting participants to easily use their own devices such as laptops, and preferred video conference platforms while also to utilize the available assets of the meeting space, just like the HDMI displays, room cameras and other USB peripherals.

The device utilizes the USB-C connectivity for a simplified transmission of 4K video, audio, control signals and power, and allows data speeds of up to 5 Gbps under the USB 3.1 Gen1 and allowing video resolution capabilities up to 4K@60Hz at 4:4:4.

The device is designed to be a centerpiece of any collaboration space, and can be connected to USB peripherals via USB-A type connectors. The series allows the hosts to be connected to the system, and also ensures quick and easy switching between these hosts, making this universal switcher a perfect fit for smaller meeting areas, involving 6-12 people.

The UCX-4x2-HC30D model also thrives when it comes to audio capabilities, offering analog audio de-embedding feature as well as support for DANTE/AES67 network connection to send DANTE/AES67 audio stream directly to a dedicated audio system. See more details in the [Dante® Audio Interface](#) section.



Dante® is a registered trademark of Audinate Pty Ltd. #new

Model Denomination

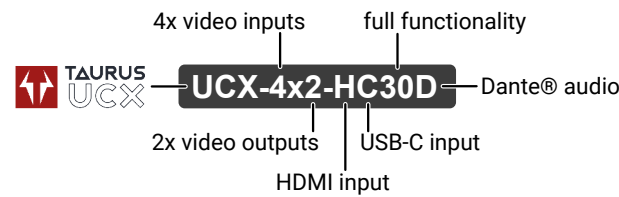

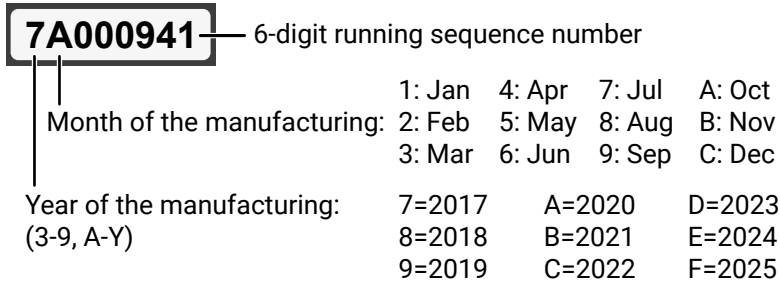

About the Serial Number

Lightware devices contain a label indicating the unique serial number of the product. The structure is the following:



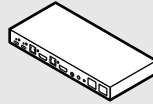

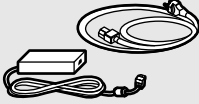
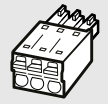
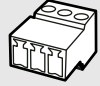
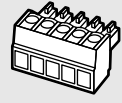
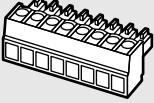
1.2. Box Contents

 Switcher unit	 Safety & warranty info, Quick Start Guide	 24V DC power adaptor with interchangeable plugs	 Phoenix combicon 3-pole connector
 Phoenix combicon 3-pole male connector	 Phoenix combicon 5-pole connector	 Phoenix combicon 8-pole connector	

1.3. Optional Accessories

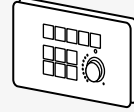
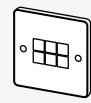
The following not-supplied accessories can be purchased and used with the device; please contact sales@lightware.com.

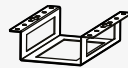
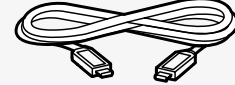
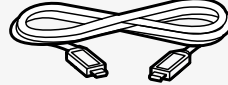
 RAP-B511 Room Automation Panel	 TBP6 Button Panel	 Rack shelf	 UD Mounting plate F100
 UD Mounting PSU F100	 USB 3.1 Type C (USB-C) to Type C (USB-C) Cable, 1m	 USB 3.1 Type C (USB-C) to Type C (USB-C) Cable, 2m	

1.4. Features of the Device

Common Features



3D and 4K Support

High bandwidth allows extension of resolutions up to 4K and even 3D sources and displays are supported.



Pixel Accurate Reclocking

Each output has a clean, jitter free signal, eliminating signal instability and distortion caused by long cables or connector reflections.



Frame Detector and Signal Analysis

The exact video and audio signal format can be determined such as timing, frequencies, scan mode, HDCP encryption, color range, color space and audio sample rate.



Autoselect Function for Video and USB Inputs

The Autoselect feature can sense the port status on the video input and USB Host ports and select them automatically. Priority number can be set for each input port and the feature allows to set various modes for the automatic input selection (First detect, Last detect).



De-embedder Function

The analog audio can be de-embedded from HDMI inputs and it can be routed to the analog audio output.



HDCP-compliant

The switcher fulfills the HDCP standard. HDCP capability on the digital video inputs can be disabled when non-protected content is used.

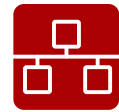

Ethernet Control

Multiple simultaneous TCP/IP connections are available with a simple ASCII-based protocol for controlling, configuring the product or perform a firmware upgrade.



GPIO Control Port *#new*

Six GPIO pins operating at TTL digital signal levels and can be controlled with LW3 commands. 5V is supplied over the 7th pin constantly, up to 500 mA.



USB 3.1 Switch

The USB 3.1 layer provides the switching of four external USB peripherals (e.g. webcam, speakerphone, multitouch display, etc.) to four independent host computers or laptops.



USB Type C Source Connection

USB Type C port ensures USB-C connectivity to the source device with USB 3.1 data and Displayport Alternate mode for video. It provides power delivery up to 60 W for the connected device (e.g. BYOD laptop or smartphone).

UCX-4x2-HC30D



Dante® or AES67 Audio De-embedding *#new*

The audio of the HDMI signal can be transmitted as a 2-channel Dante® or AES67 source from the -D model over the dedicated RJ45 connector.

1.5. Typical Application

UCX-4x2-HC30 - Example 1.

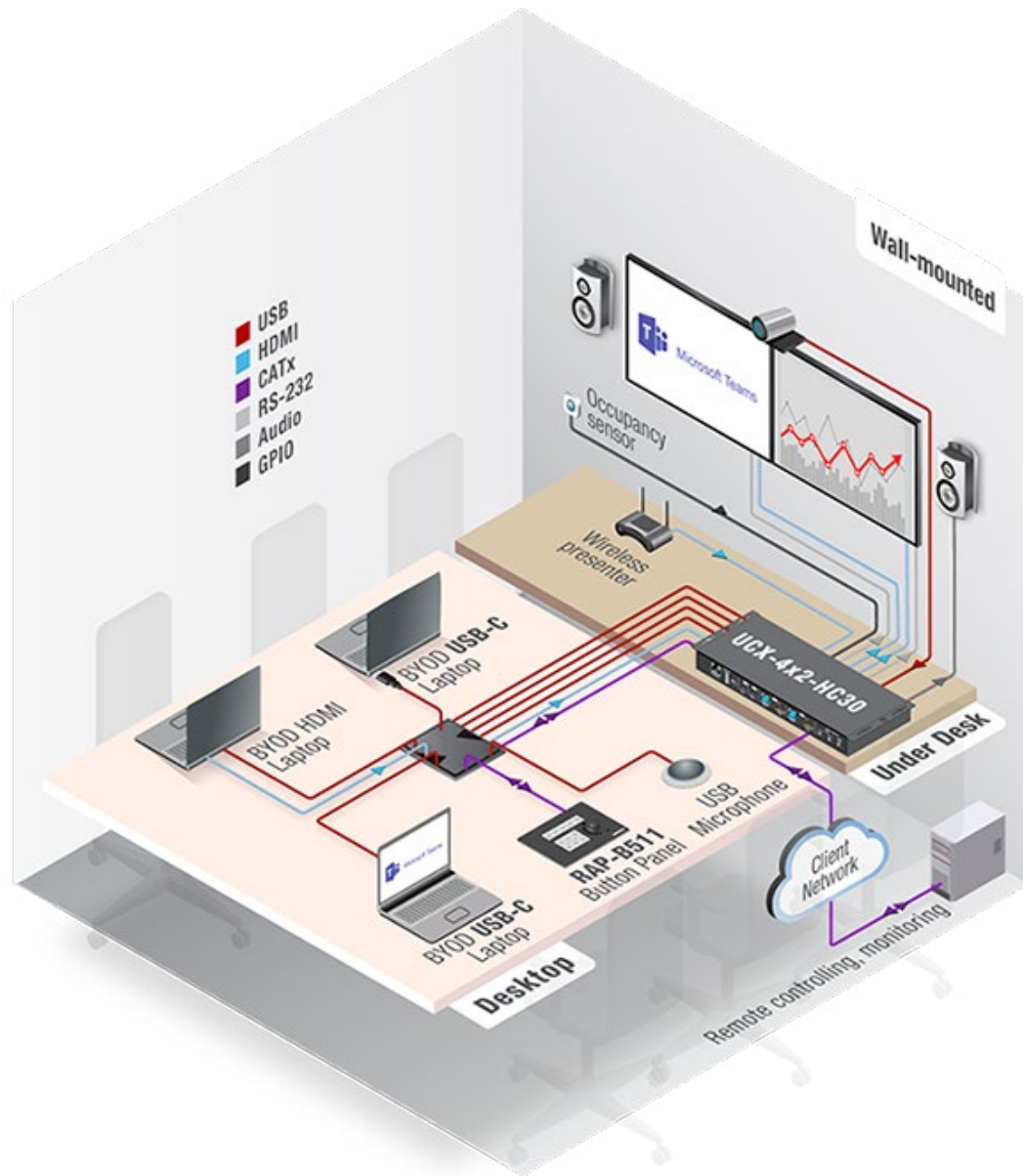

UCX-4x2-HC30 - Example 2.

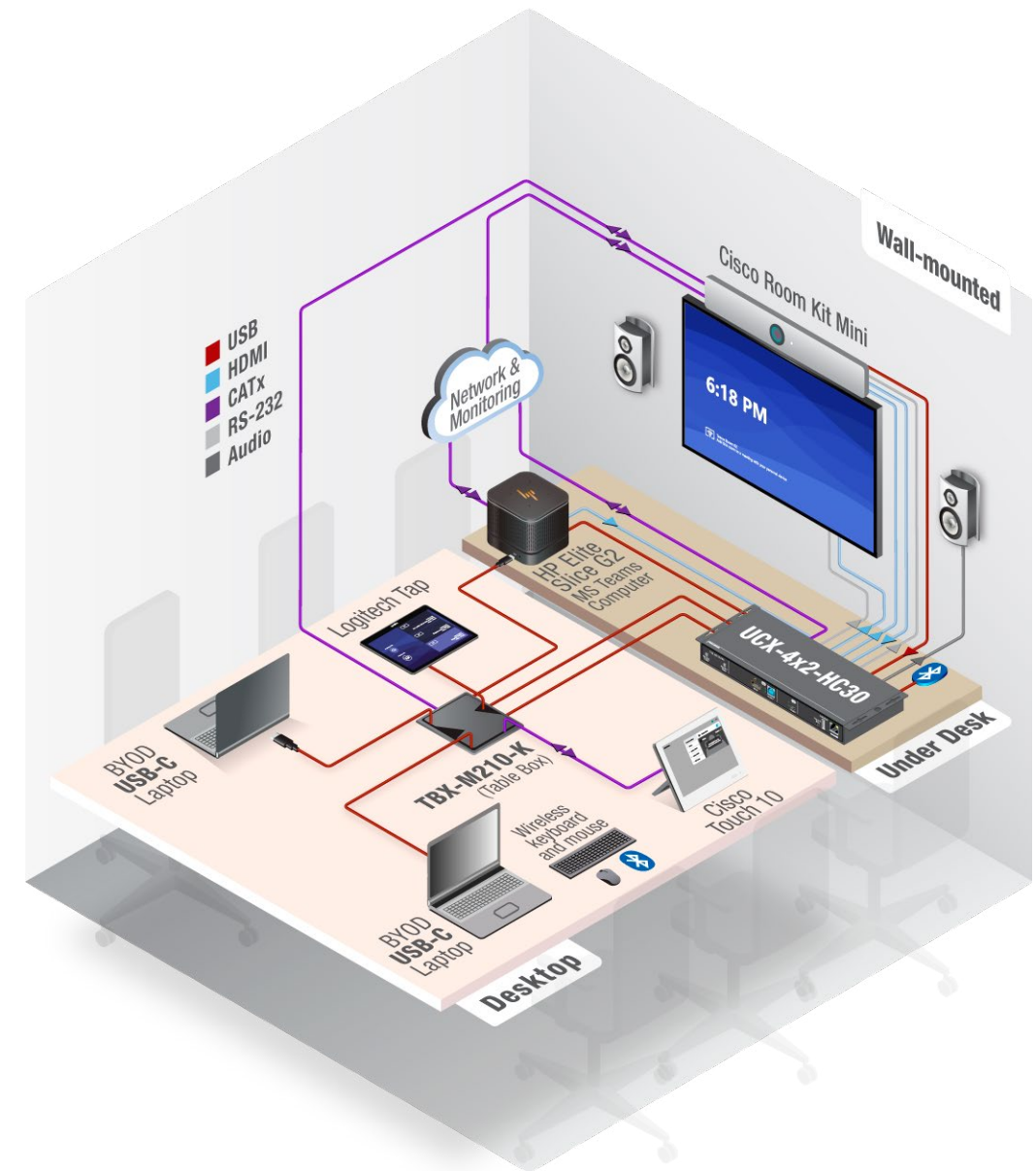

2

Product Overview

The following sections are about the physical structure of the device, input/ output ports and connectors:

- ▶ [FRONT VIEW](#)
- ▶ [REAR VIEW](#)

2.1. Front View

UCX-4x2-HC30

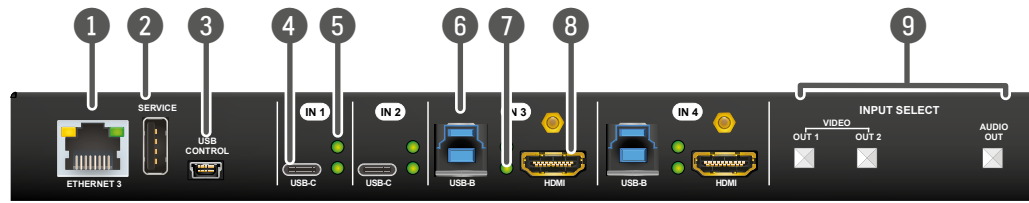

UCX-4x2-HC30D #new

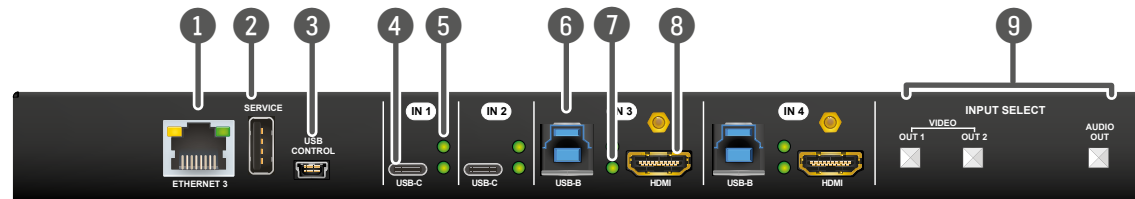

- 1 **Configurable Ethernet Port** RJ45 connector for configurable 100Base-T Ethernet communication.
- 2 **USB-A Port** The firmware upgrade function will be added by future firmware upgrade.
- 3 **USB mini-B Port** The service function will be added by future firmware update.
- 4 **USB-C Ports** Displayport 1.2 and USB 3.1 Gen1 connections, AV signal can be transferred up to a resolution of 4K@60Hz 4:4:4 and data speeds up to 5 Gbps with remote charging. The applied cable shall not be longer than 3m. For more details about the cables, see [USB-C Cable Recommendation](#) section.
- 5 **Video Input Status LEDs** See the details in [Front Panel LEDs](#) section.
- 6 **USB-B Ports** Upstream ports for connecting USB host devices (e.g. computer).
- 7 **USB Status LEDs** See the details in [Front Panel LEDs](#) section.
- 8 **HDMI Input Ports** HDMI input ports for sources. The applied cable shall not be longer than 5m. Use cables certified for HDMI 2.0 (3x6Gbps) applications.
- 9 **Input Select Buttons** For more details, see the [Button Functionality](#) section.

INFO: Connecting USB B and HDMI ports to the same PC or laptop is recommended in case of IN3 and IN4 inputs.

2.2. Rear View

UCX-4x2-HC30

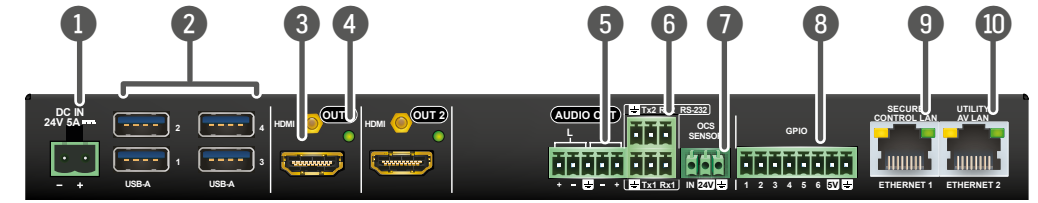

UCX-4x2-HC30D #new

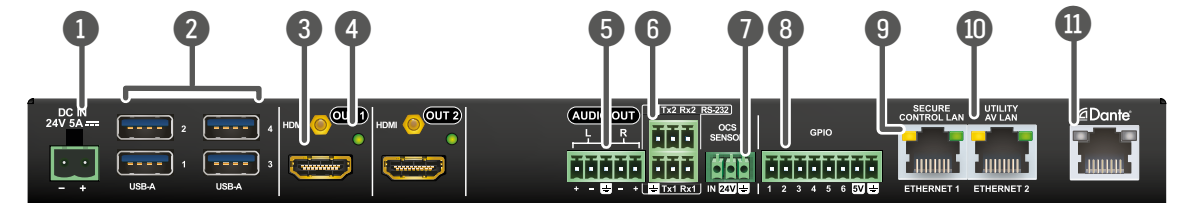

- 1 **DC Input** The device can be powered by an external 120W power supply. Connect the output to the 2-pole Phoenix® connector. For more info about the powering, see [Powering Options](#) section.
- 2 **USB-A Port** Downstream ports for connecting USB peripherals (e.g. camera, keyboard, multitouch display) with USB 3.1 Gen1 data speed.
- 3 **HDMI Output Ports** HDMI output ports for connecting sink devices.
- 4 **Video Output Status LEDs** See the details in [Rear Panel LEDs](#) section.
- 5 **Analog audio port** 5-pole Phoenix® connector for balanced analog audio output signal. The signal is de-embedded from the selected video signal.
- 6 **RS-232 ports** This function will be added by future firmware update.
- 7 **OCS sensor** 3-pole Phoenix® connector (male) for connecting an occupancy sensor. The port provides 24V output voltage (50mA).
- 8 **GPIO** 8-pole Phoenix® connector for configurable general purpose.
- 9 **Secure Control LAN** RJ45 connector for configurable 100Base-T Ethernet communication.
- 10 **Utility AV LAN** RJ45 connector provides room utility Ethernet connection for e.g BYOD laptops.
- 11 **Dante® Audio Output** RJ45 connector for de-embedding the HDMI audio which can be transmitted as a 2-channel Dante® or AES67 source.

WARNING! Always use the supplied power supply. Warranty void if damage occurs due to use of a different power source.

3

Front Panel Control

The following sections are about front panel operation of the device and the status LEDs:

- ▶ [BUTTON FUNCTIONALITY](#)
- ▶ [STATUS LEDs](#)

3.1. Button Functionality

3.1.1. Video Source Selection

Push OUT1 to select the video input for the HDMI OUT1 port.
 Push OUT2 to select the video input for the HDMI OUT2 port.
 Push AUDIO OUT to set the audio source of the analog audio output.
 The sequence is the following: *#switch #crosspoint*

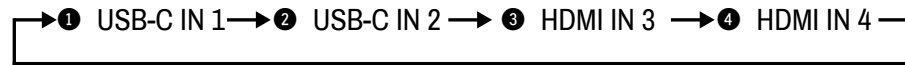

3.1.2. Reset to Factory Default Settings

To restore factory default values, do the following steps:

- Step 1.** Make sure the switcher is powered off.
- Step 2.** Press and keep pressed the **VIDEO OUT2** button. Power on the switcher while the **VIDEO OUT2** button is being pressed.
- Step 3.** The LEDs get dark, the device restores the factory default settings and reboots. Factory default settings are listed in the [Factory Default Settings](#) section. *#factory*

3.2. Status LEDs

3.2.1. Front Panel LEDs

Arrangement of the status LEDs *#status*

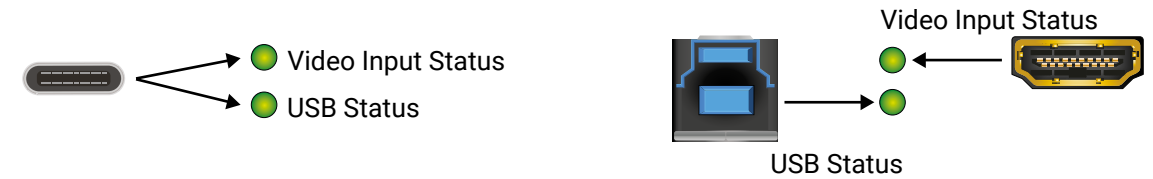

Video Input Status LED (the upper one)		
	off	There is no valid video signal on this port.
	on	There is a valid video signal on this port.
	blinks once	The port is selected by a button press.
USB Status LED (the below one)		
	off	No USB Host or deselected port.
	on	USB Host connected and selected.
	blink at once	The port is selected by a button press.



3.2.2. Rear Panel LEDs

Video Output Status		
	off	The signal is not present or muted.
	on	The video signal is present.

3.2.3. Ethernet Status LEDs

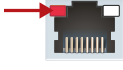
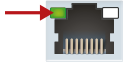

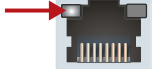
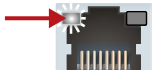



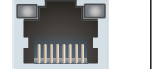

DIFFERENCE: The color of the left Ethernet LED is red up to v2.0 hardware version. It does not refer to any error, On/Off/Blinking state indicates the same function as the left green one (above v.2.1) The hardware version can be found in the [Status](#) menu in the LDC.

Left LED color	HW version
	Up to v2.0
	v2.1 and above

LED state	Left LED	Function
	Off	Not linked
	On (Solid)	No activity
	Blinking	Activity
LED state	Right LED	Function
	Off	0 Mbit/s
	On (Solid)	100 Mbit/s

3.2.4. Dante® Audio Out (in UCX-4x2-HC30D model)

DIFFERENCE: UCX-4x2-HC30D model has Dante® Audio Output. *#new*

LED state	Left LED	Right LED	Function
	Off	Off	No power
	Solid green	Solid red	Dante is booting
	Blinking green	Solid green	Slave with sync (normal operation)
	Blinking green	Blinking green	Clock master (normal operation)
	Blinking green	Blinking red	Acquiring clock sync (normal operation)
	Alternating red/green	Alternating red/green	Identify (blinking for 6 seconds)
	Blinking red	Blinking red	Dante fail safe
	Blinking orange	Blinking orange	Dante is upgrading

4

Installation

- ▶ MOUNTING OPTIONS
- ▶ ELECTRICAL CONNECTIONS
- ▶ POWERING OPTIONS
- ▶ POWER DELIVERY
- ▶ USB-C CABLE RECOMMENDATION
- ▶ CONNECTING STEPS

4.1. Mounting Options

To mount the switcher Lightware supplies optional accessories for different usage. There are two kinds of mounting kits with similar fixing method. The switcher has two mounting holes with inner thread on the bottom side; see the bottom view in the [Mechanical Drawings](#) section. To order mounting accessories please contact sales@lightware.com. Fasten the device by the screws enclosed to the accessory.

WARNING! Always use the supplied screws. Using different (e.g. longer) ones may cause damage to the device.

4.1.1. 1U High Rack Shelf

Allows rack mounting for half-rack, quarter-rack and pocket sized units.



1U high rack shelf provides mounting holes for fastening two half-rack or four quarter-rack sized units. Pocket-sized devices can also be fastened on the shelf.

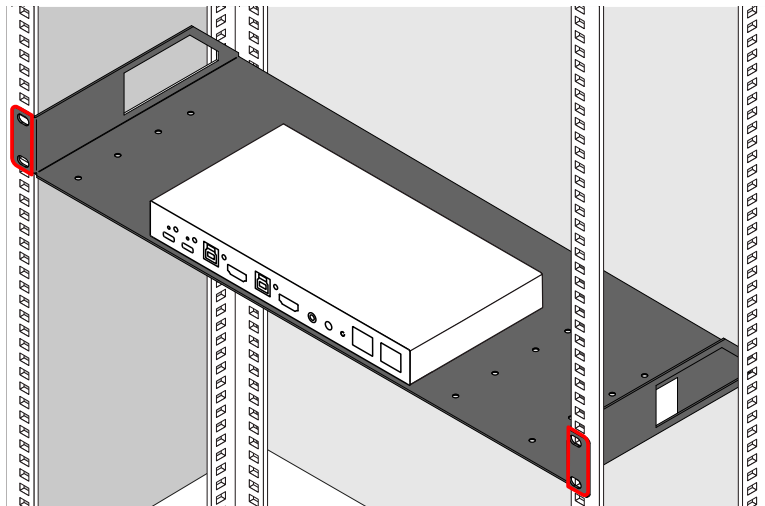

4.1.2. Mounting the Device (with optionally available accessories)

The examples demonstrate the applications of UD Kit accessories: *#new*

Step 1. Turn the switcher and the power adaptor upside down.

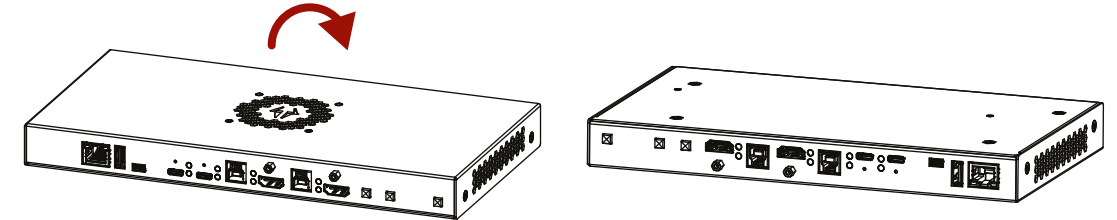

Step 2. Fix the UD Mounting plate F100 to the switcher by fastening the screws (these 2pcs screws are supplied with the switcher).

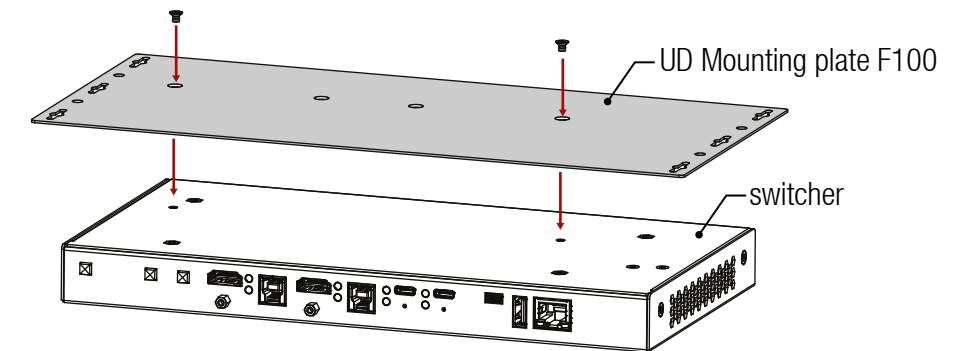

Step 3. Insert the power supply into the UD Mounting PSU F100.

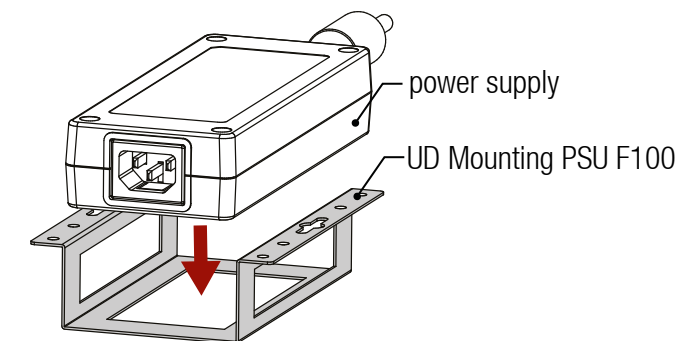

Step 4. Fix the **UD Mounting plate F100** and **UD Mounting PSU F100** under the desk by fastening the screws.

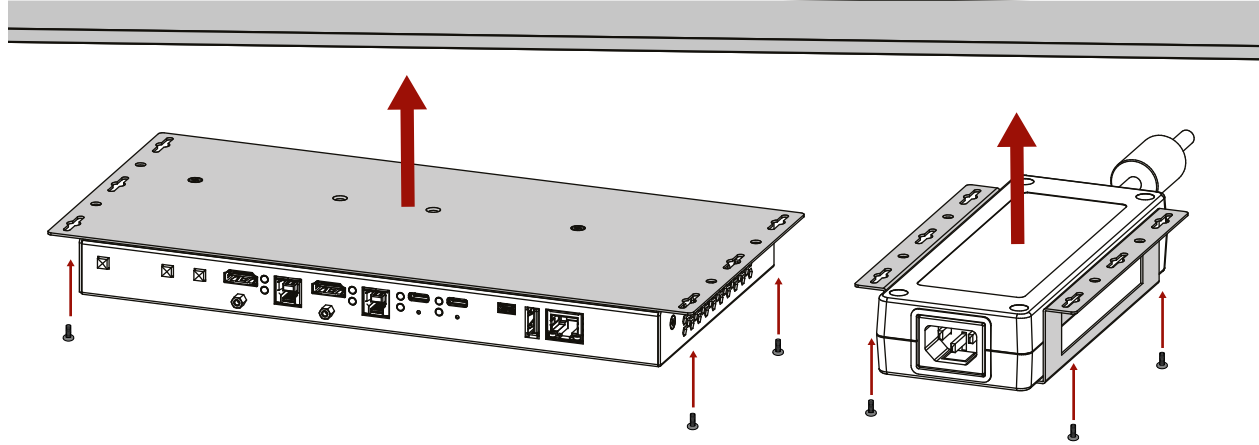

INFO: **UD Mounting plate F100** and **UD Mounting PSU F100** do not contain the fixing screws, they can be purchased from the local hardware store. 2x4pcs M3-M5 metric or wood screws needed, M3 size is recommended.

ATTENTION! To ensure the correct ventilation and avoid overheating, insert the switcher face down to the **UD Mounting plate F10** to keep the ventilation holes free.

4.1.3. Ventilation

WARNING! Never block the ventilation holes on any side of the switcher! Ensure the proper ventilation by letting the free airflow.

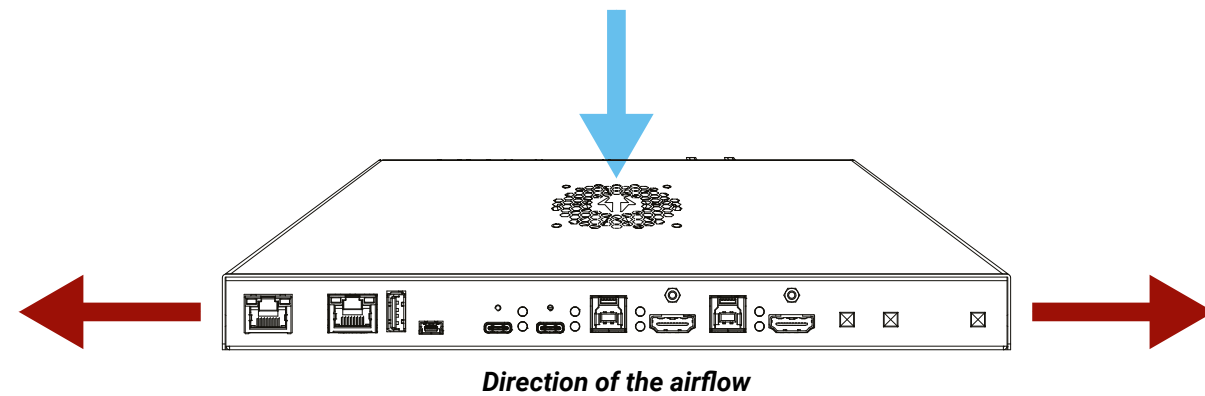

4.2. Electrical Connections

4.2.1. HDMI Input and Output Ports

The UCX series switchers are assembled with standard 19-pole HDMI connectors with screw lock for inputs and outputs. Always use high quality HDMI cable for connecting sources and displays.



4.2.2. USB Connectors

USB Type-C



The switchers are supplied with USB 3.1 Gen1 (max. 5 Gbps data speed) USC C-type port for video, USB data, and Ethernet transmission. It provides power delivery for max. two connected devices up to 60W or 2 x 30W. Supported power profiles: 5V/3A, 9V/3A, 12V/3A, 15V/2A, 15V/3A, 20V/1.5A, 20V/3A. USB-C connector has symmetrical plug and pin layout.



ATTENTION! USB 2.x and 3.x data transfer happens on two independent layers simultaneously.

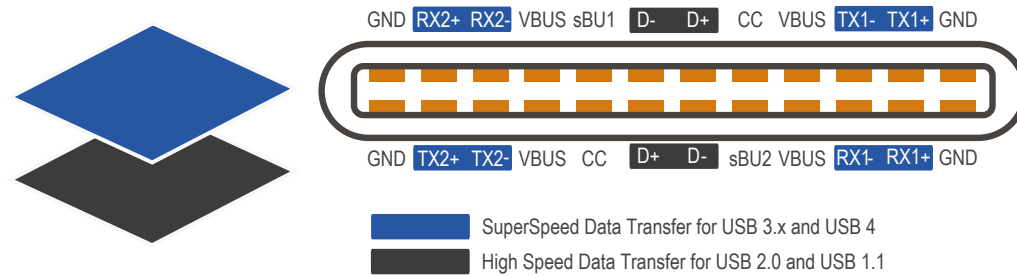

The pinout of the USB-C connector

ATTENTION! USB-C functionality and speed depend on the cable and the device. Mandatory features of the USB-C - USB-C cables are: USB 2.0(480 Mbps), min. 3A current, min. 60W power.

USB Type-A



Taurus UCX series have USB 3.1 Gen1 (max. 5 Gbps data speed) USB A-type ports for connecting USB peripherals. 5V output power capability can be turned on and off for all ports. All ports are able to supply 1000mA.



INFO: Blue color inside the connector refers to the USB 3.0 data speed.

USB Type-B



The switcher is supplied USB 3.1 Gen1 (max. 5 Gbps data speed) B-type port for connecting USB hosts.



INFO: Blue color inside the connector refers to the USB 3.0 data speed.

4.2.3. Analog Stereo Audio

5-pole Phoenix connector is used for balanced analog audio output. Unbalanced audio device can be connected as well. See more details about the balanced and unbalanced output port wiring in the [Cable Wiring Guide](#) section.



Pin nr.	Signal
1	Left+
2	Left-
3	Ground
4	Right-
5	Right+



Analog audio connector and plug pin assignments

Compatible Plug Type

Phoenix® Combicon series (3.5mm pitch, 5-pole), type: MC 1.5/5-ST-3.5.

4.2.4. Secure Control LAN, Utility AV LAN, Configurable Ethernet Port

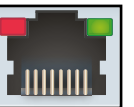

INFO: The connector type and the applied cable is the same for the Dante® audio output.

The switcher contains an RJ-45 connector for 100Mbit Ethernet/LAN connection for local control functions. The Ethernet ports can be connected to a LAN hub, switch or router by a CATx cable. However both cable types (straight or cross) are supported and handled by the device, below pin assignment is recommended.

Wiring of LAN Cables

Lightware recommends the termination of LAN cables on the basis of TIA/EIA T 568 A or TIA/EIA T 568 B standards.

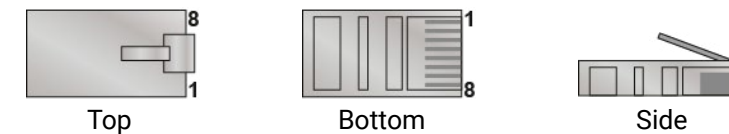

Pin	TIA/EIA T568A	Wire color	TIA/EIA T568B	Wire color
1		white/green		white/orange
2		green		orange
3		white/orange		white/green
4		blue		blue
5		white/blue		white/blue
6		orange		green
7		white/brown		white/brown
8		brown		brown

4.2.5. OCS Connector

The switcher is supplied a 3.81mm 3-pole 90° Reversed Gender Plug Phoenix® connector which is used for connecting an occupancy sensor. *#new*

The first pin has a logic low and high level, the default state is low. The output voltage changes automatically 24V when detects an incoming signal from the connected occupancy sensor.

The second pin has a constant 24V output voltage and the third one is the ground.



Pin nr.	Level and direction
1	low and high level changes
2	24V
3	Ground

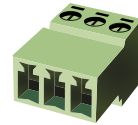

OCS connector pin assignments

Voltage ranges for 1nd pin are the following:

	Input voltage [V]
Logic low level	0 - 0.8
Logic high level	2V- 24V

OCS Output Voltage Level: 24V (50mA).

Depending on the third-party device push-up or pull-up resistor may be required. Please contact Support (support@lightware.com) about the details.

TIPS AND TRICKS: In case of applying Leviton OCS (<https://www.leviton.com/en/products/osc10-m0w>) supply a 1 kOhm external resistor between the 1st and the 3rd legs is necessary.

Compatible Plug Type

WR-TBL series (3.81mm 3-pole 90° Reversed Gender Plug Phoenix), type: WR-TBL Series 3483 - 3.81 mm.

TIPS AND TRICKS:

4.2.6. GPIO - General Purpose Input/Output Ports

The switcher is supplied a 8-pole Phoenix connector with six GPIO pins, which operates at TTL digital signal levels and can be set to high or low level (Push-Pull). The direction of the pins can be input or output (adjustable). Voltage ranges for GPIO inputs are the following: *#new*

	Input voltage [V]	Output voltage [V]	Max. output current [mA]
Logical low level	0 - 0.8	0 - 0.5V	30
Logical high level	2 - 5	4.5 - 5V	18

The maximum total current for the six GPIO pins is 180 mA.

Pin nr.	Level and direction
1	Configurable
2	
3	
4	
5	
6	
5V	
Ground	

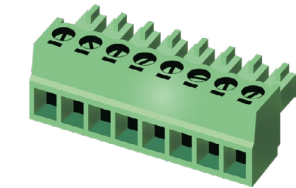

GPIO connector and plug pin assignments

INFO: The recommended cable for the connectors is the AWG24 (0.2 mm² diameter) or the generally used 'alarm cable' with 4x0.22 mm² wires.

Compatible plug type

Phoenix® Combicon series (3.5mm pitch 8-pole), type: MC 1.5/8-ST-3.5.

4.3. Powering Options

Remote Powering via USB-C Ports

The UCX series devices are designed to provide power delivery for the connected device over the USB-C connectors.

The following operation modes are available:

- Charge one device on the chosen port with up to 60W. The other port can supply up to 5V/3A. Supported power profiles: 5V/3A, 9V/3A, 12V/3A,, 15V/3A, 20V/3A

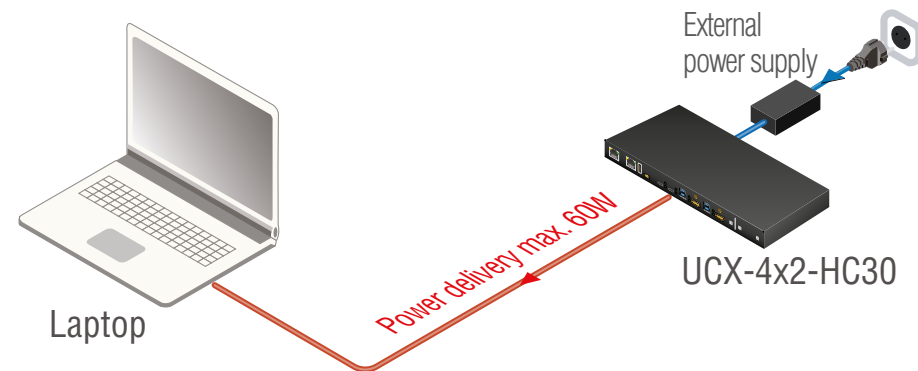

- Charge one device with 30W (in this case , the other USB-C port can supply 30W or 5V/3A) Supported power profiles: 5V/3A, 9V/3A, 15V/2A, 20V/1,5A

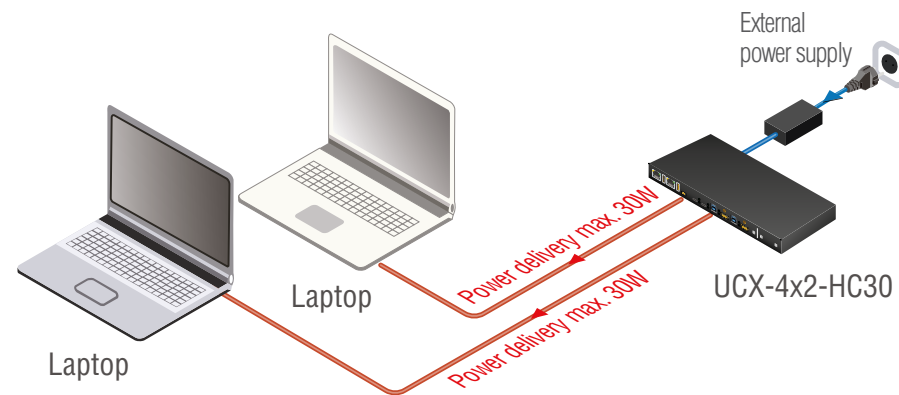

INFO: Selecting the appropriate power profile happens automatically, no manual intervention required.

Remote Powering via USB-A Ports (D1-D4)

5V output power capability can be turned on and off for all ports. All ports are able to supply 1000mA.

4.4. Power Delivery

With Power delivery, these issues were solved: *#new*

- Allows negotiation of **up to 60 W** of power delivery to supply or charge equipment connected to a USB-C port.
- Power direction is **not fixed**.
- Intelligent and flexible system-level **management of power** (negotiation); the two connected partners exchange real-time PD protocol messages through the CC (control channel) lines.

USB SuperSpeed or DisplayPort Alternate Mode
USB High Speed Data Transfer 480 Mbps
Power Delivery (up to 60 W)

USB PD supersedes all the previous technologies and does not incorporate them. It can achieve any of the previous levels, but does so with its own methods.

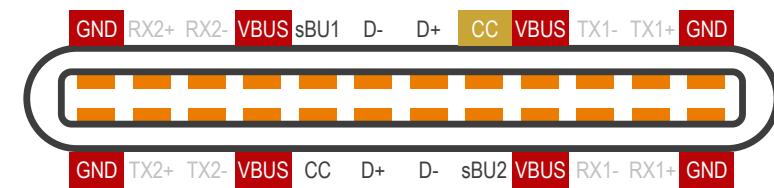

Power Pins of USB-C Connector

- The VBUS and GND pins are power and the return paths for the signals
- The CC channel is used for power negotiation
- The other CC pin can be used for VCONN powering

USB Chargers

USB-C PD covers a range of different power levels, with different amperage and voltage combinations that a charger can deliver, depending on what the device asks for and the cable negotiates. These values are defined by PDO (Power Data Objects).

According to the specification, 12V is not a mandatory Voltage level. The reason for supporting in case of certain chargers is that the 12V value was on the mandatory list of a former specification.

4.4.1. Power Data Objects (USB-C)

Power Data Object (PDO) defines a power capability:

- Nominal voltage and maximum current
- A Source must have at least one PDO
- The Sink chooses one of the Sources PDOs via CC communication

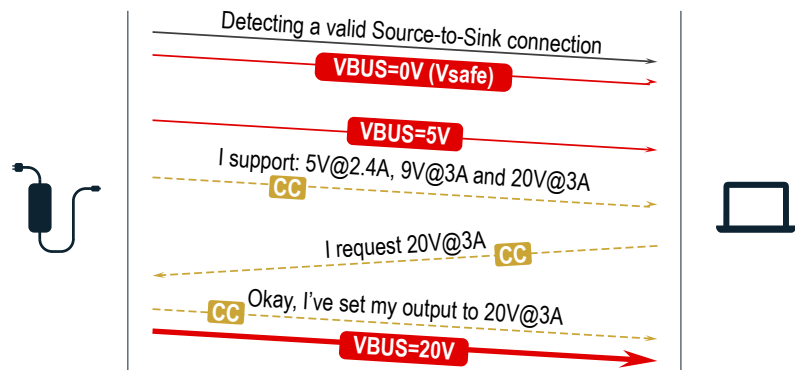
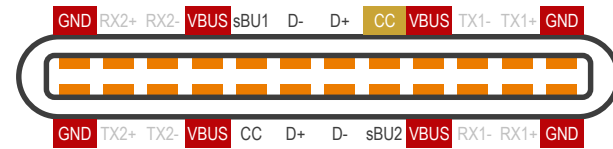

Powering Handshake

Dual-Role Power *#new*

With USB-C the connector is the same on all products. Laptops, certain tablets and smartphones can be both a charger and a charged device (not simultaneously). Source/Sink defines the power role the port is currently operating in.

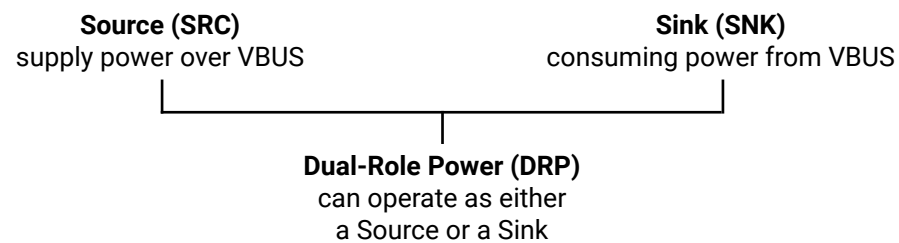

	Source-only	Sink-only	Dual-Role Power
Source-only	Non-functional	Functional	DRP = Sink
Sink-only	Functional	Non-functional	DRP = Source
Dual-Role Power	DRP = Sink	DRP = Source	DRPs negotiate

4.5. USB-C Cable Recommendation

Please find the below recommendation for the applied cables:

- Use Full-featured USB Type-C cables made by reliable brands.
- USB2.0 cables miss the Superspeed channels, neither DP video nor USB3 transmission works with them.
- Type-C cables certified for USB 3.x Gen1-Gen2 (5Gbps or 10Gbps) and Displayport Alternate mode HBR2-HBR3 (5.4Gbps or 8.1Gbps) applications are recommended.
- Thunderbolt cables are not backwards compatible to USB3.x or Displayport unless the manufacturer explicitly states so.
- Passive, 20Gbps Thunderbolt 3 cables which are also specified for USB3.x are a good, but more expensive choice.
- 5A charging capability is not required. All USB Type-C cables should support at least 3A (up to 60W) charging.
- When more than 2m long cable is needed, please contact the sales (sales@lightware.com) for the cable recommendation.

4.6. Connecting Steps

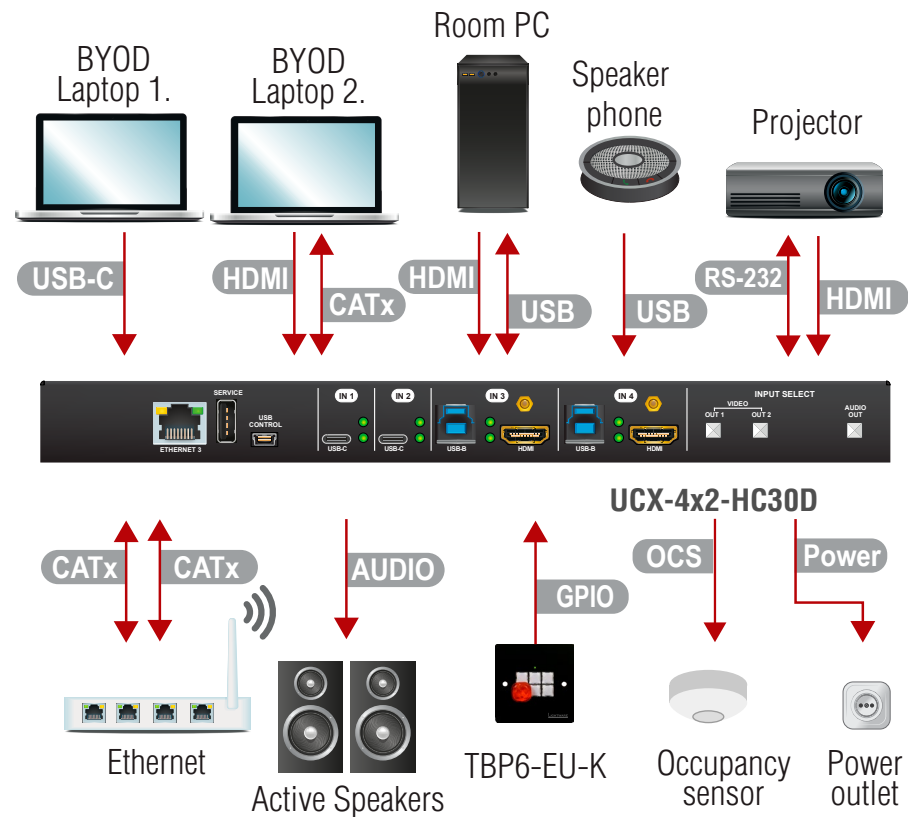

USB-C Connect a USB-C source (e.g. BYOD laptop) to the USB-C input port. The applied cable shall be certified for USB 3.1 Gen1 (5Gbps) and Displayport Alternate mode HBR2 (4x5.4Gbps) applications.

HDMI Connect an HDMI source (e.g. BYOD laptop or room PC) to the HDMI input port.

CATx Connect a device (e.g. BYOD laptop) to the Utility Ethernet port to access the internet or local network.

USB **USB Type-A:** Optionally connect the USB device (e.g. Speaker phone).
USB Type-B: Optionally connect the USB host (e.g. PC).

HDMI Connect an HDMI sink (e.g. projector) to the HDMI output port.

Audio Optionally connect an audio device (e.g. active speakers) to the analog audio output port by an audio cable.

GPIO Optionally connect a device (e.g. TBP6-EU-K button panel) to the GPIO port. *#new*

OCS Optionally connect an occupancy sensor to the OCS port. *#new*

Power Connect the external power supply to the AC power socket and the switcher unit. Powering the device is recommended as the final step.

INFO: Connecting USB B and HDMI ports to the same PC or laptop is recommended in case of IN3 and IN4 inputs.

5

Device Concept

The following chapter describes the features of the device with a few real-life examples.

- ▶ [UNIVERSAL SWITCHER CONCEPT](#)
- ▶ [USB INTERFACE](#)
- ▶ [VIDEO INTERFACE](#)
- ▶ [THE AUTOSELECT FEATURE](#)
- ▶ [AUDIO INTERFACE](#)
- ▶ [ETHERNET INTERFACE](#)

5.1. Universal Switcher Concept

UCX-4x2-HC30

Lightware's universal switcher exploits the USB-C connectivity for a simplified transmission of 4K video, audio, control signals and power providing meeting participants with easy host switching, utilizing data speeds of up to 5 Gbps under the USB 3.1 Gen1 providing video supporting up to 4k@60Hz at 4:4:4 video resolution.

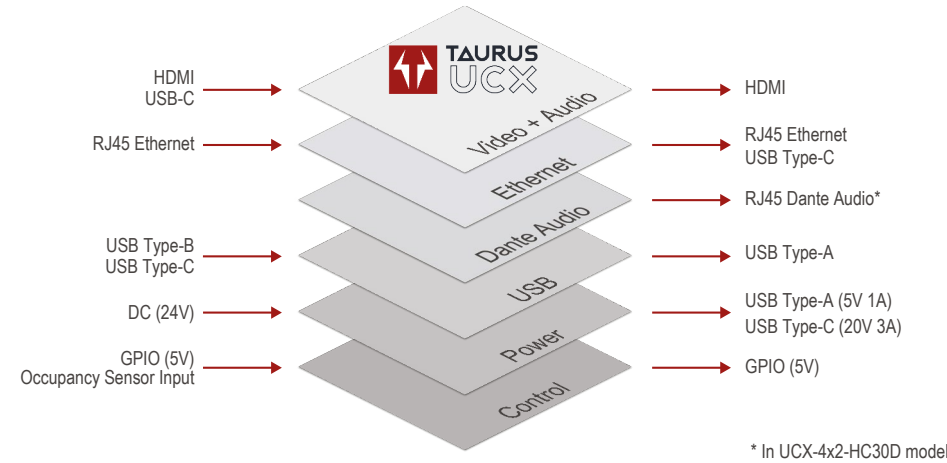

5.2. USB Interface

5.2.1. USB-C Interface

Summary of USB-C Ports

	USB-C 3.1 Gen1 (5 Gbps)
UCX-4x2-HC30	2x
UCX-4x2-HC30D	2x

USB-C Pinout and Data Channels

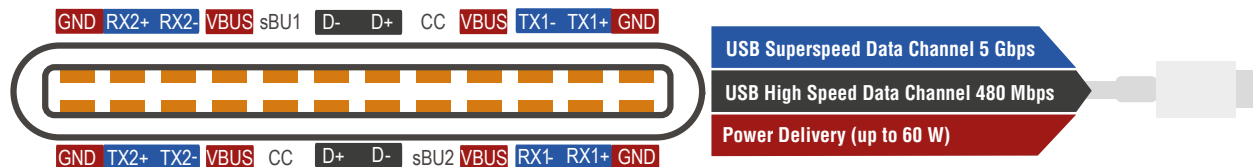

USB-C interface consist of three main layers:



USB Data

- Taurus UCX series supports USB 3.1 Gen1 (max. 5 Gbps data speed) on their USB-C ports. This data is transmitted on the USB Superspeed data channels.
- USB 2.0 data (480 Mbps) is transferred on the High-speed data channels. The built-in USB-Ethernet bridge provides Ethernet connection over the USB-C connector. This function uses the High-speed channels. For more details see [USB Port Diagram](#) and [Ethernet Interface](#) section.

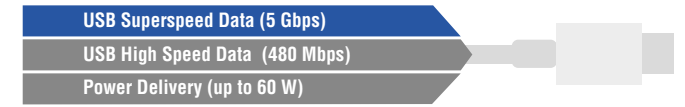

INFO: USB.2.x and 3.x data transfer happens on independent two layers simultaneously.



Displayport Alternate Mode (Video + Embedded Audio)

- DisplayPort Alternate Mode:** Alternate mode is designed for carrying uncompressed, native Displayport video as a non-USB data (All Superspeed Data lanes deliver video signals, it reserves the whole bandwidth of the SS Lines).
- DisplayPort Alternate mode and USB 3.1 data shared: AV signals and USB 3.1 data are transmitted at the same time, shared the bandwidth (2 SuperSpeed lines for video + 2 SuperSpeed lines for USB 3.1).

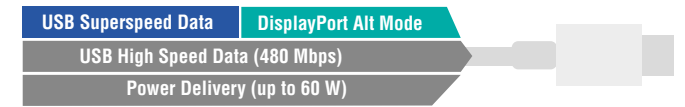
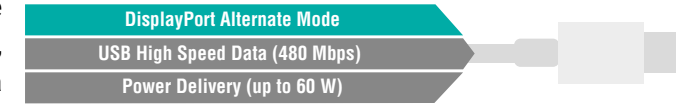
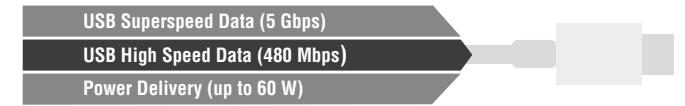

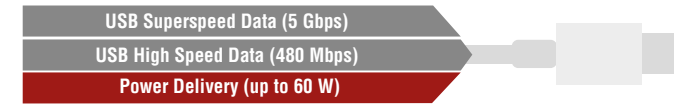

Power Delivery

- Outgoing to power/charge external devices



5.2.2. USB Data - USB 3.1 Gen1 Interface

Summary of USB 3.1 Gen1 ports

	Upstream & Downstream ports (DFP)	Upstream ports (UFP)	Downstream ports (DFP)
	USB-C 3.1 Gen1 (5 Gbps) 	USB-B 3.1 Gen1 (5 Gbps) 	USB-A 3.1 Gen1 (5 Gbps) 
UCX-4x2-HC30	2x	2x	4x
UCX-4x2-HC30D	2x	2x	4x

USB Port Diagram

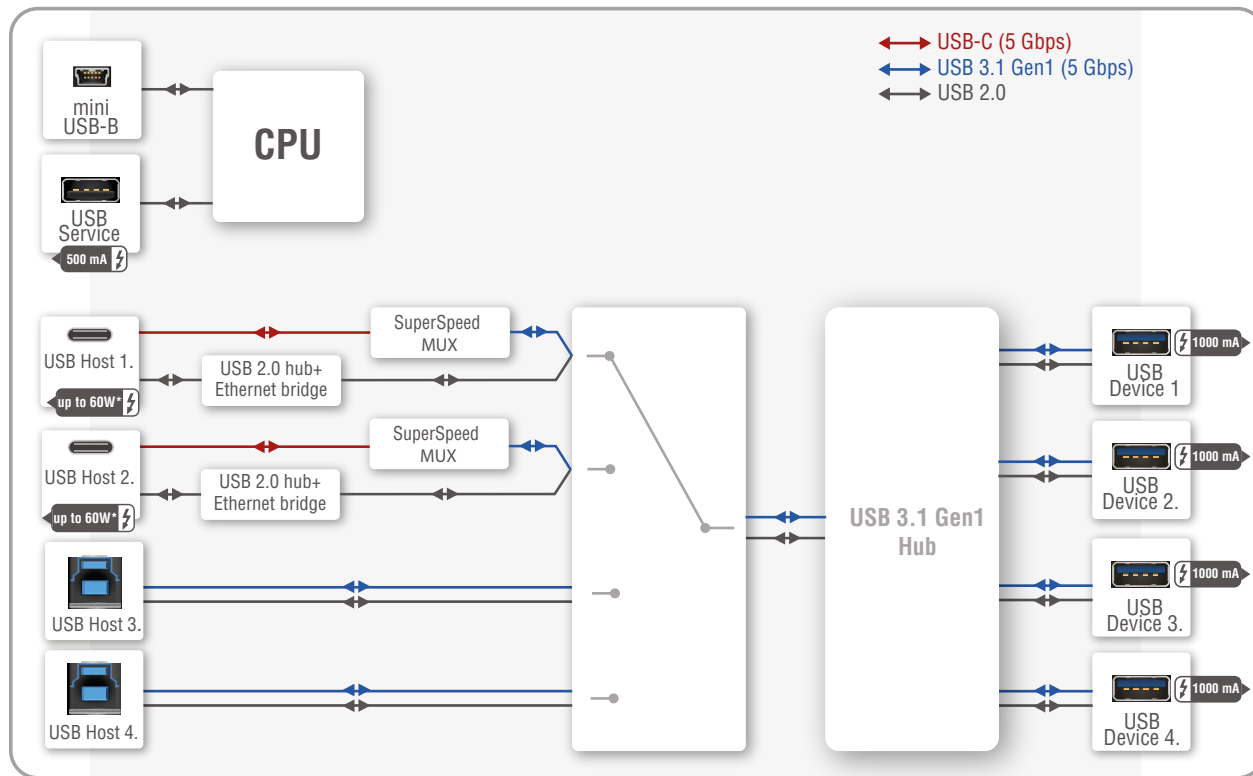

The USB 3.1 standard is backwards compatible. This means the High-speed channels (USB 2.0 lines) are used if the connected device or cable capability is only USB 2.0.

USB-A, USB-B and USB-C connectors also have high-speed data lines besides Superspeed.

The built-in USB-Ethernet bridge provides Ethernet for the USB-C connection. It is still available while the USB 3.1 Gen1 data channels are reserved for video or USB data transmission. For more details, see [Ethernet Port Diagram](#).

INFO: USB.2.x and 3.x data transfer happens on two independent layers simultaneously.

USB Features

DisplayPort Alternate Mode

This function is available only for USB type C connectors. See more details in [DisplayPort Alternate Mode](#) section.

Host detection

One host is available at the same time. Taurus UCX series devices give a feedback about the connected hosts.

In case of USB Type-B ports: When the 5V is detected on USB Vbus, the **Connected** property becomes true.

In case of USB Type-C ports: USB Type-C introduced the port Power Roles: Sink port, Source port and Dual Role Power port. Supplying VBUS is not the privilege of the USB Host anymore.

Detecting the presence of a BYOD device on Type-C ports is done using the Power Delivery protocol over the Communication Channel.

*For more details about the power delivery of the USB-C port see [Powering Options](#) section.

INFO: The Taurus UCX series devices generally present 1 tier in the USB topology (a HUB). An exception is the USB2 layer on Type-C ports, which present two tiers (two HUBs).

Sending 5V Power to the Device

This function allows sending 5V power to the device (USB peripheral). Most USB devices powered by this 5V, so disable and enable this property is equal with unplug and plug the USB connector.

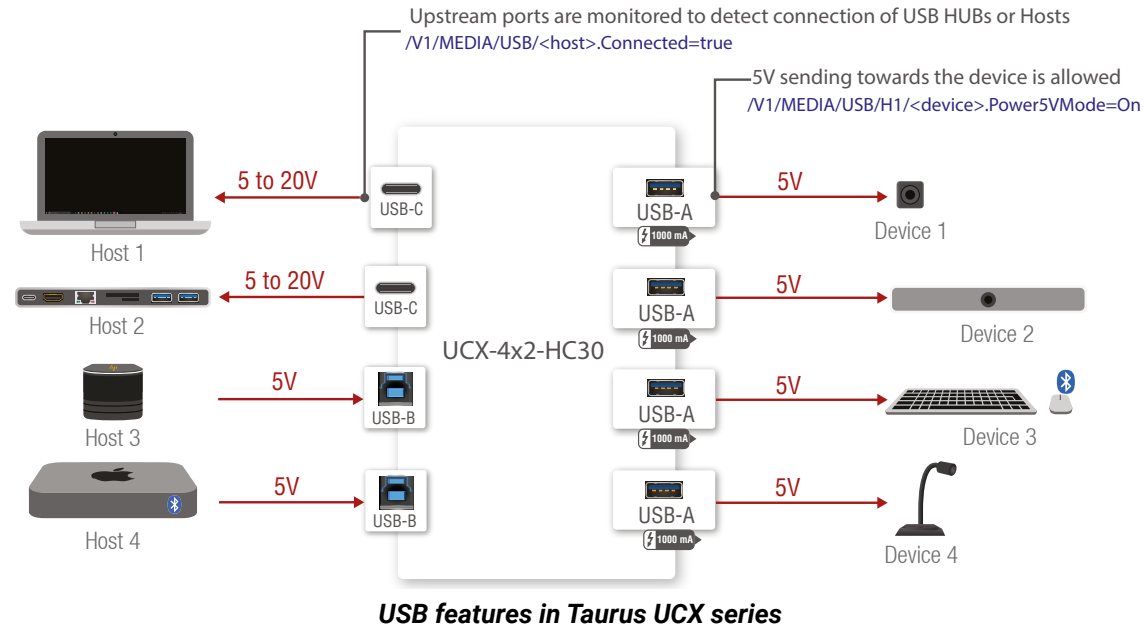

Application of USB - Example

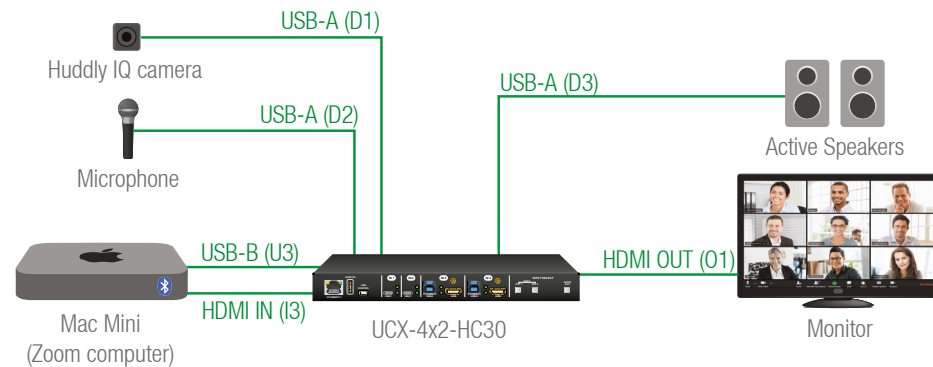

The Concept

The Webcam and USB microphone (D2) are connected to the Mac Mini computer(U3) through a USB HUB (Taurus UCX). Zoom running on the computer sends video and embedded audio signal to the Taurus HDMI input (I3).

The switcher forwards analog audio to the active speakers and digital video to the HDMI display.

Settings

- Step 1.** In the Crosspoint menu, USB tab, switch the Mac Mini (U3) to the USB hub(H1).
- Step 2.** Pay attention to the connected USB devices (D1 and D2) and turn on the **Power 5V Mode**.
- Step 3.** The video crosspoint is switched to I3-O1.

5.2.3. USB Service Ports - USB 2.0 Interface



Summary of USB 2.0 ports

	Service ports	
	USB-A USB 2.0 (480 Mbps)	mini USB- B USB 2.0 (480 Mbps)
UCX-4x2-HC30	✓	✓
UCX-4x2-HC30D	✓	✓

The **SERVICE**-labelled USB-A connector and mini B-type connector is designed for service function. It will be added by future firmware update.

5.3. Video Interface

Summary of Video Ports

	Video Inputs		Video Outputs
			
	Displayport Alternate mode HBR2 (4x5.4Gbps)	HDMI 2.0 (18 Gbps)	HDMI 2.0 (18 Gbps)
UCX-4x2-HC30	2x	2x	2x
UCX-4x2-HC30D	2x	2x	2x

Video Port Diagram

INFO: The source, which is connected to the USB-C port, sends DisplayPort video signal. This signal is converted to HDMI by the video IC internally.

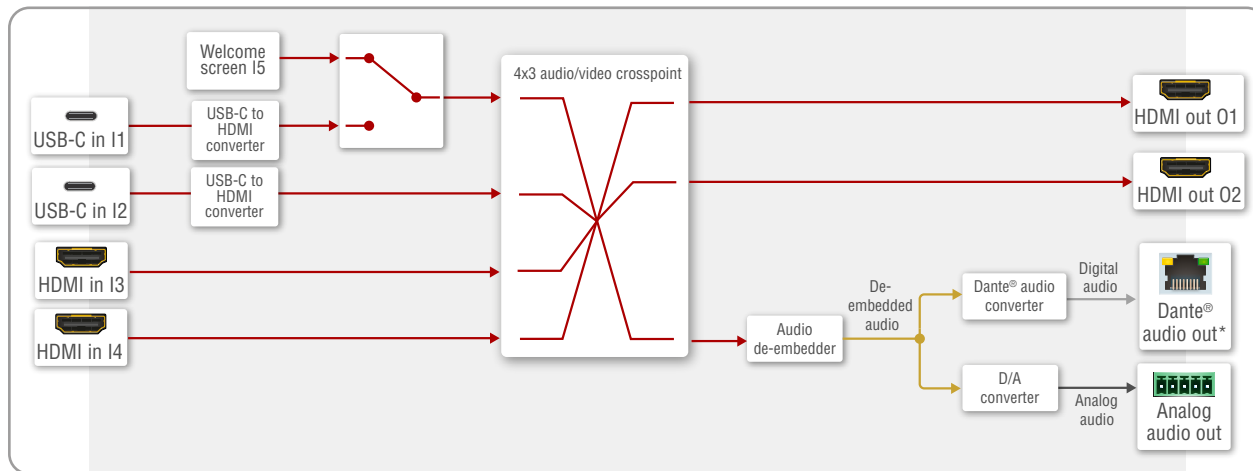

* UCX-4x2-HC30D model has Dante® Audio Output.

Video port diagram with the internal image source (Welcome screen)

ATTENTION! Video crosspoint has a limitation: I1 and I5 ports are not available at the same time, only one of them can be selected to any output. **Busy** label on the crosspoint tile refers to the limitation. Welcome screen is an internal source which can be customized by uploading image file (jpg, jpeg or bmp).

5.3.1. DisplayPort Alternate Mode

USB-C sources sends Displayport signal for video transmission.

Displayport Alternate mode allows using the USB-C cable instead of DisplayPort cable for DP video signals. The standard uses the Superspeed data transfer channels for carrying the video stream.

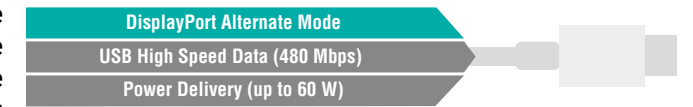

ATTENTION! The bandwidth of the video is based on the capacity of the source and the sink. USB3.1 Generation (Gen1=5Gbps, Gen2=10Gbps) is not related to DP bitrate (HBR1=4x2.7Gbps, HBR2=4x5.4Gbps)

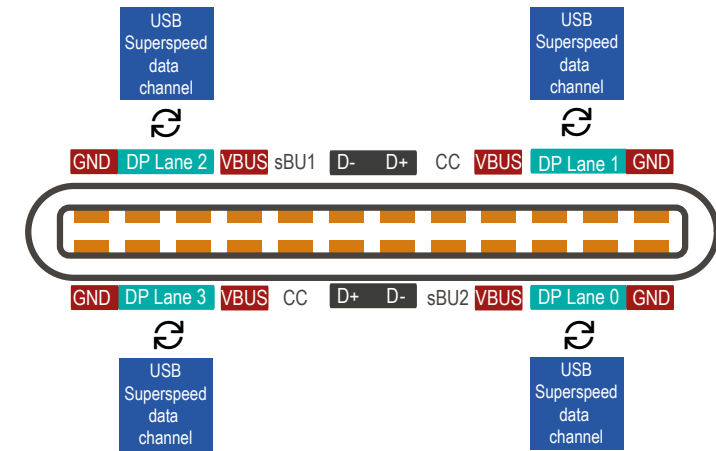

USB-C pinout in DP Alt mode

In Alt Mode, 2 or all 4 of the USB-C Superspeed data channel can be configured as DisplayPort lanes. A full-bandwidth DisplayPort connection is always defined as 4 lanes.

The table below shows the correlation of the video resolution and the assigned lanes:

DisplayPort Video			DisplayPort Alternate Mode			
DisplayPort Standard	Raw bandwidth (1 lane)	Display Resolutions	2-Lane DP		4-Lane DP	
			BW	Display Resolutions	BW	Display Resolutions
HBR1 (DP 1.0 / 1.1)	2.7 Gbps	1440p@60 Hz	5.4 Gbps	1 × FullHD	10.8 Gbps	1 × 4K@30 Hz
HBR2 (DP 1.2)	5.4 Gbps	4K@60 Hz	10.8 Gbps	1 × 4K@30 Hz	21.6 Gbps	1 × 4K@60 Hz

5.3.2. DisplayPort Alternate Mode and USB 3.x Mixed

The two different signals (video and USB 3.x) can be transmitted at the same time with shared bandwidth.

DP video reserves 2x Superspeed Channels for the video signal in alternate mode. 2x Superspeed Channels for USB 3.x This setting can be configured manually via [Software Control - Lightware Device Controller](#) or via LW3 protocol commands (for more details see [LW3 Programmers' Reference](#) section).

5.3.2.1. Thunderbolt Compatibility

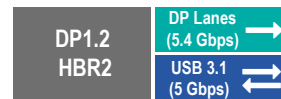

Thunderbolt 3 standard uses USB-C connector to transmit data. The standard is compatible backwards, so it is able to fallback Displayport Alternate mode. In this case, the maximum bandwidth of transmitted video signal based on the connected sink capability (e.g. HBR2, 5.4Gbps per lane in case of UCX-4x2-HC30 switcher).

5.4. The Autoselect Feature

DIFFERENCE: The autoselect feature for USB layer is available only from FW package v1.1.0b7.

Beside of manual selecting of crosspoints you can choose the Autoselect option in case of video and USB ports.

Video input source can be selected the following ways:

- using the front panel buttons
- using Lightware Device Controller (LDC);
- sending or LW3 protocol commands; or
- using the Autoselect function.

There are three Autoselect policy as follows:

- Disable autoselect
- First detect
- Last detect
- Follow video (in case of USB and audio ports)

INFO: SignalPresent cannot be sensed on I1 if i5 is displayed due to the mutually exclusive operation of video input I1 and the internal Welcome screen image generator I5. Welcome screen image will disappear and the video XP will be switched to I1 upon connecting a Host computer to I1 regardless the computer sends Displayport image or not.

Individual input settings

This setting defines the priority level of the port. The priority property is valid both for first detect and last detect operation modes. It overrides the chronological order of the appearance of the active video signal. Always the highest priority active input is selected to transmit (1- highest priority, 100- lowest priority).

TIPS AND TRICKS: To use the individual input settings, change the default priority settings from 1 to 5 depending on their importance (e.g. I1 priority:1; I2 priority:2; I3 priority:3; I4 priority:4; I5 priority:5).

ATTENTION! The autoselect function remains active after the manual crosspoint switching. This operation mode works contrary to the other Lightware matrix switchers or extenders).

Disable autoselect

The crosspoint state change only happens manually.

First detect

The selected input port is kept connected to the output as long as it has an active signal. The crosspoint changes, when the signal becomes inactive on the chosen input, or when the video signal appears on a higher priority port.

TIPS AND TRICKS: To prevail the first detect mode, default priority settings (I1 priority:50; I2 priority:50; I3 priority:50; I4 priority:50; I5 priority:100) are appropriate. Lower priority of the I5 port is highly recommended, because this is an internal source with constant video signal, this port is always the first one.

Last detect

Always the last attached input is selected to transmit. The crosspoint changes, when the signal becomes inactive on the chosen input, or when the active video signal appears on a port with the same or higher priority.

TIPS AND TRICKS: To prevail the last detect mode, default priority settings (I1 priority:50; I2 priority:50; I3 priority:50; I4 priority:50; I5 priority:100) are appropriate.

Automatic Input Selection- Example 1.

The Welcome screen appears on the Monitor 1. (O1) when no active source connected.

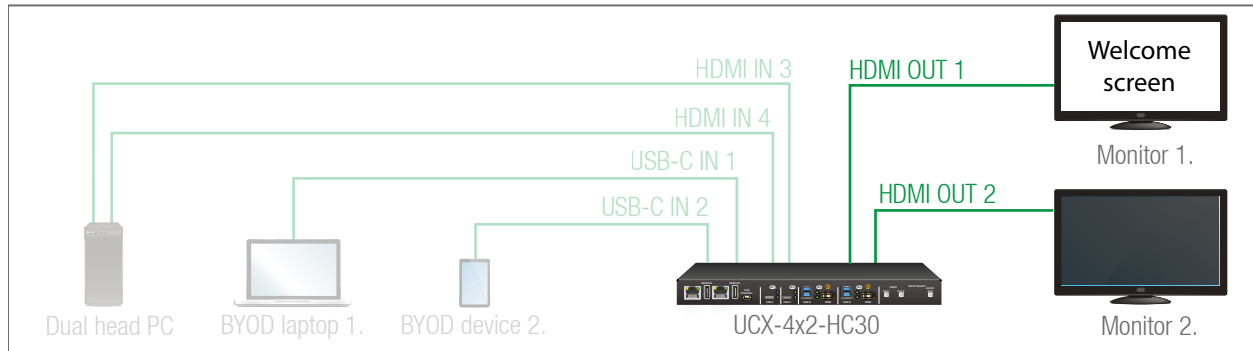

The video signal of the dual-head PC (I3, I4) can be seen on Monitor 1. and Monitor 2. (O1 and O2) when it is powered on and no BYOD device is connected.

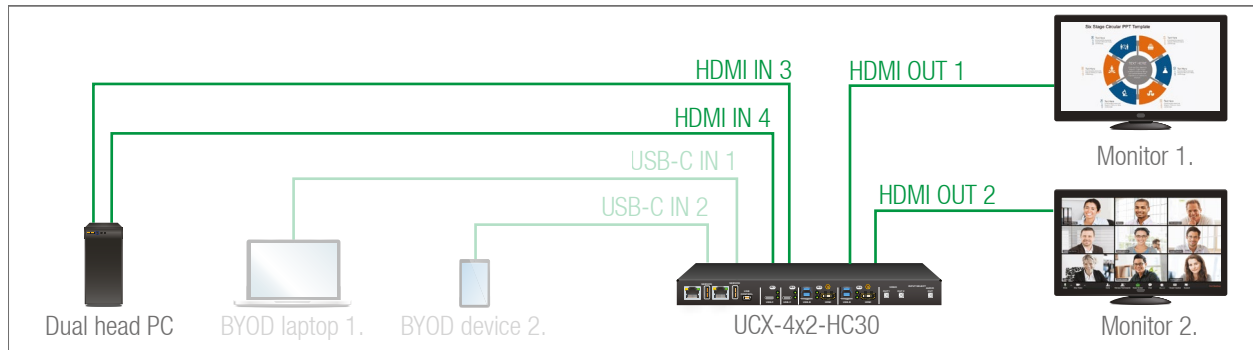

BYOD laptop 1. (I1) is displayed on Monitor 1. (O1) and BYOD device 2. (I2) can be seen on Monitor 2. when they are connected and send active video signal.

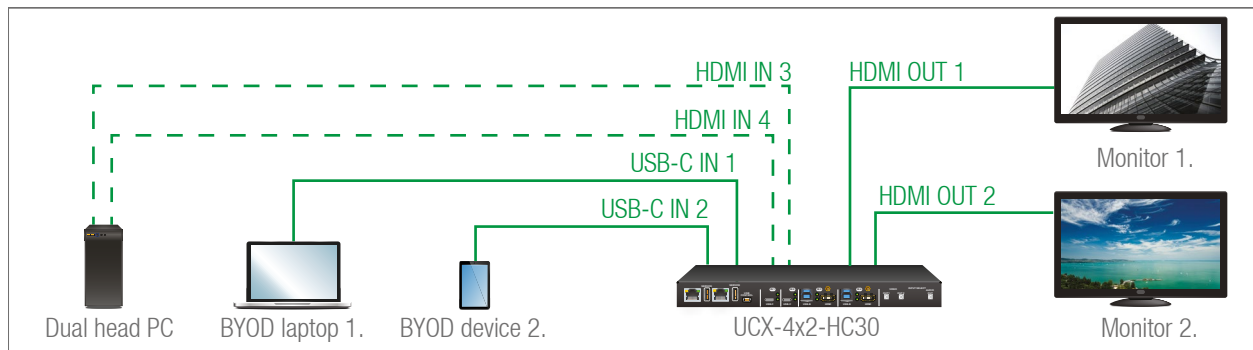

The individual input settings are the following:

O1: I1 priority:1; I2 priority: disabled; I3 priority:2; I4 priority: disabled; I5 priority:3

O2: I1 priority: disabled; I2 priority: 1; I3 priority: disabled; I4 priority: 2; I5 priority: disabled

Automatic Input Selection - Example 2.

One of the BYOD laptop is switched to the Monitor 1. depending on the operation policy (Last detect/first detect) and the connection order of the BYOD laptops. The USB autoselect mode should be **Follow video**, the USB peripherals (webcam, microphone etc.) are connected to the chosen laptop. The USB Type-C provides Ethernet to the BYOD device, so the conferencing software can run there.

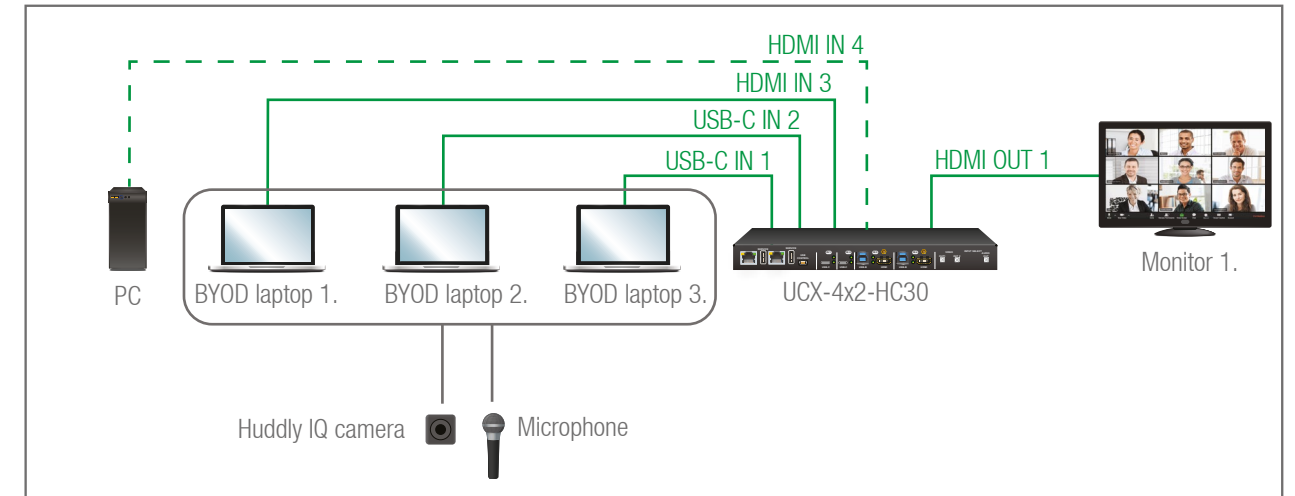

When no active BYOD device is connected and the local PC is powered on, the UCX-4x2-HC30 is switched to I4 and transmits the video to the Monitor1.

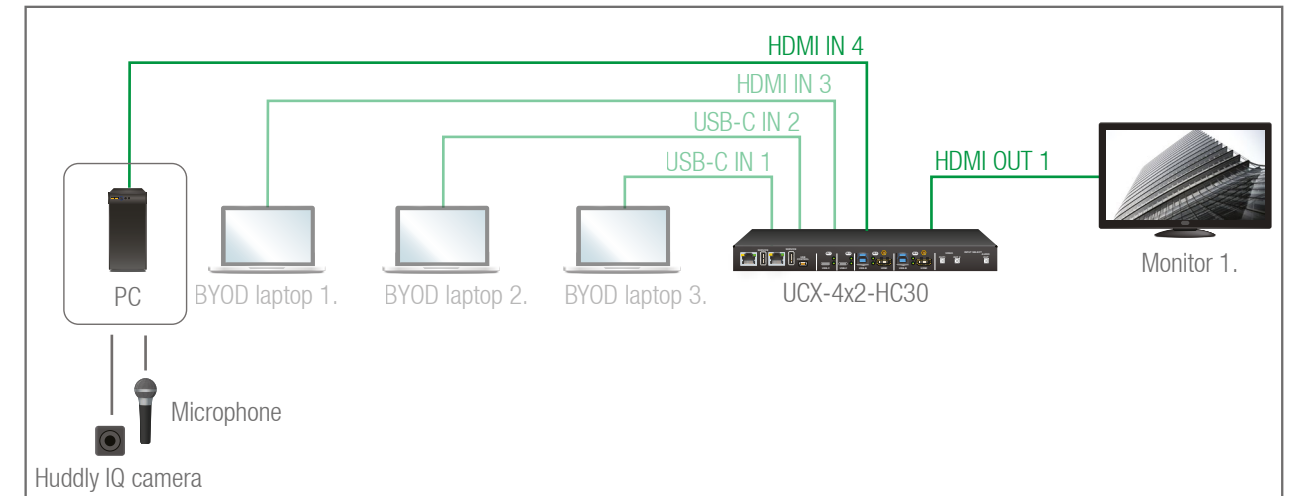

The individual input settings are the following:

O1: I1 priority:1; I2 priority: disabled; I3 priority:2; I4 priority: disabled; I5 priority:3

Automatic Input Selection - Example 3.

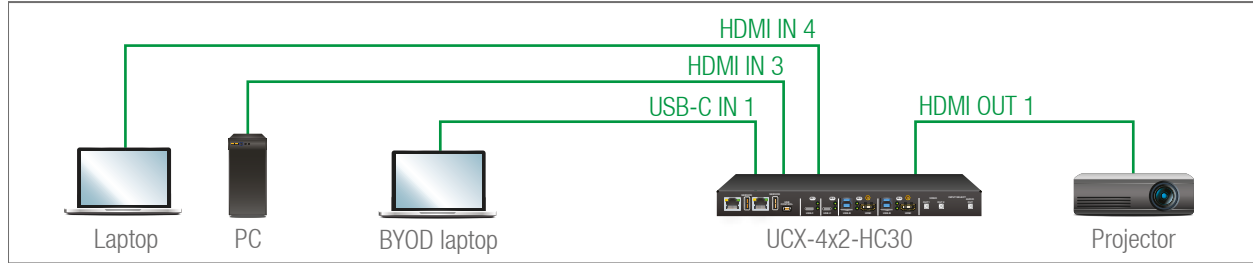

The laptop on HDMI input 4 will be automatically switched to the HDMI output if there is no other source connected to the switcher. If the PC is powered on and has active video signal, the HDMI input 3 will be switched to the HDMI output. If the BYOD Laptop is connected through the USB-C input 1, it will be switched to the HDMI output – independent of the presence of the other video signals.

Set the Autoselect mode is Last detect for HDMI out 1: The priorities are the followings (the lowest number means the highest priority):

Source device	Input port	Priority
Laptop	I4 (HDMI in 4)	3
PC	I3 (HDMI in 3)	2
BYOD Laptop	I1 (USB-C in 1)	1

Priorities can be set in Lightware Device Controller software, see related settings in the [HDMI Video Output](#) section.

Automatic Input Selection - Example 4.

DIFFERENCE: The autoselect for USB layer feature is available only from FW package v1.1.0b7.

The Welcome screen appears on the Monitor 1. (O1) when no active source connected.

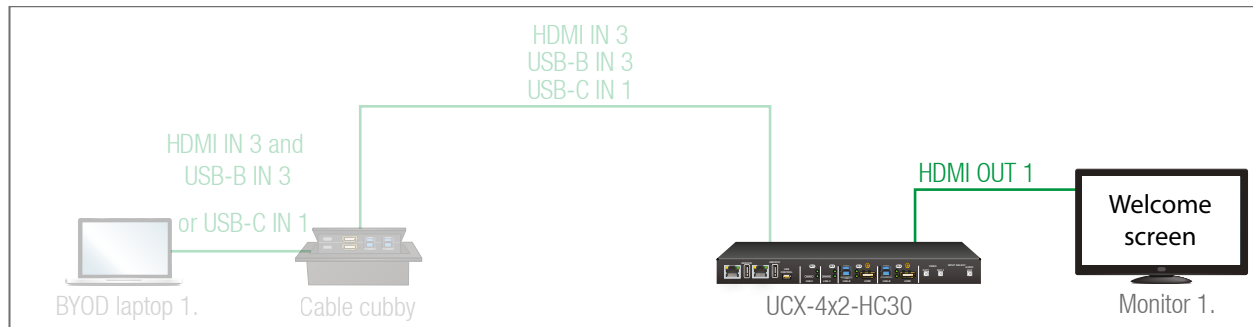

A presenter can choose what cable(s) are appropriate to their BYOD. Either USB Type-C cable alone for both USB and Displayport, or one USB cable (USB-B or USB-C) for data and one HDMI cable for video can be used.

The Taur UCX series device will switch both USB and video layers accordingly.

Cable cubby for BYOD #1 has three cables connecting to USB-C (In1), USB-B (In3), HDMI (In3).

Case 1.

When the BYOD laptop uses HDMI for video and USB-B for data.

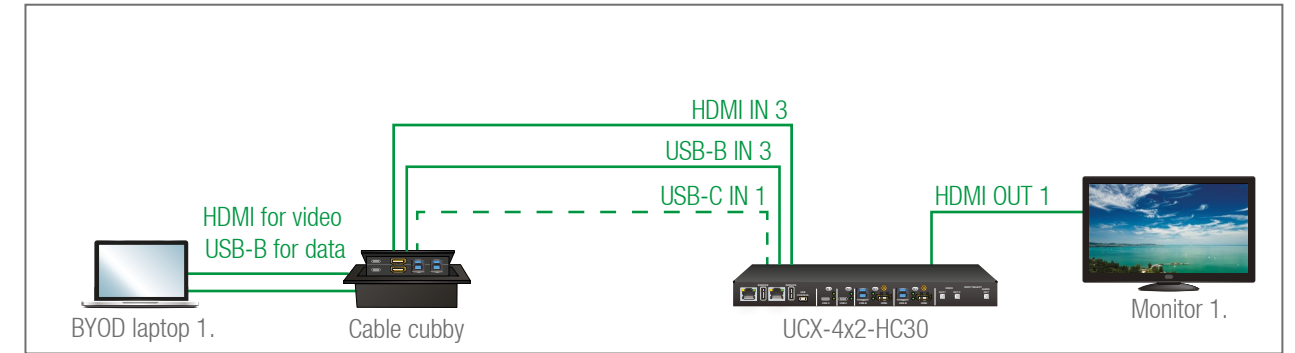

Case 2.

When the BYOD laptop uses HDMI for video and USB-C for data.

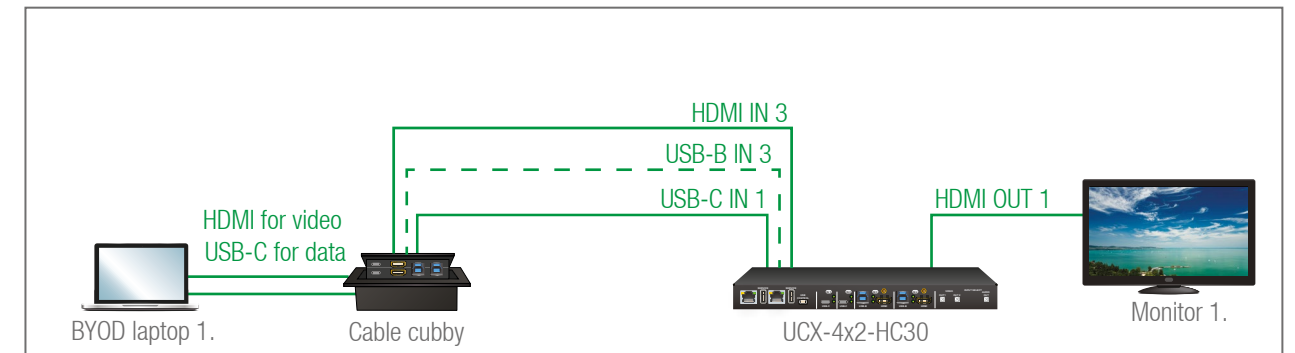

Case 3.

When the BYOD laptop uses HDMI for video and USB-C for data.

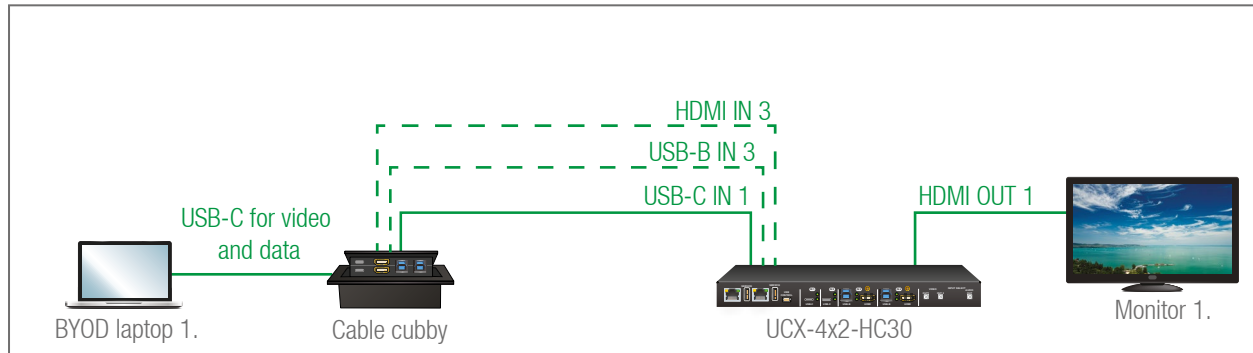

The individual input settings are the following:

Video

O1:Last detect; I1 priority:1; I2: disabled; I3 priority:1; I4: disabled; I5 priority:2

ATTENTION! Take care that the O2 video is not switched to I5 because of the crosspoint limitation: I1 and I5 ports are not available at the same time, only one of them can be selected to any output.

USB

H1: Last detect, U1 priority:1; U2 priority:1; U3 priority:1; U4 priority:1

5.5. Audio Interface

Summary of Audio Ports #new

	Audio Outputs	
	Analog audio de-embedding 5-pole Phoenix Combicon	 RJ45
UCX-4x2-HC30	✓	✗
UCX-4x2-HC30D	✓	✓

Video and Audio Port Diagram.

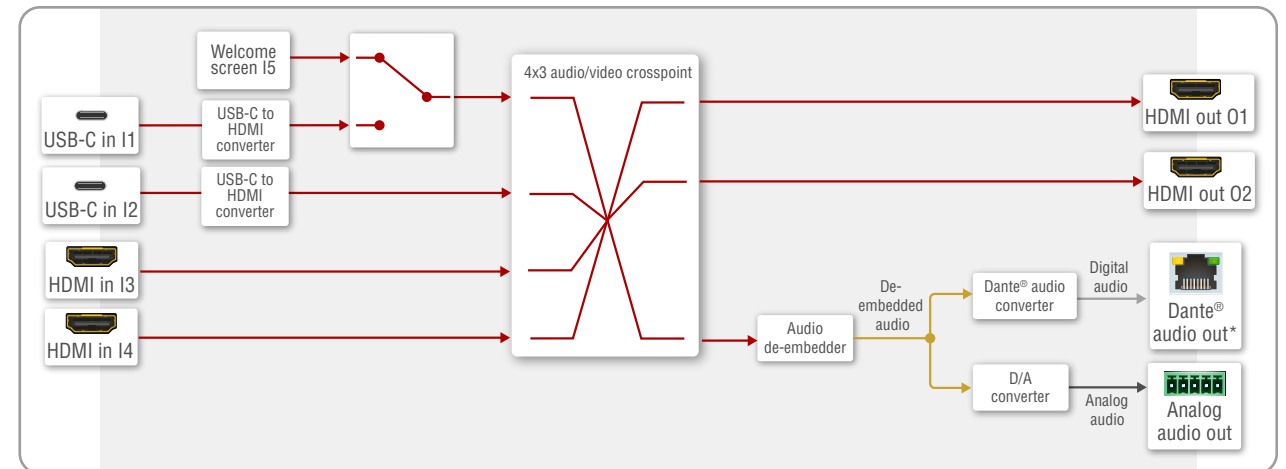

* UCX-4x2-HC30D model has Dante® Audio Output.

5.5.1. Analog Audio Interface

The device can receive embedded audio signal on the HDMI or USB-C inputs.

The switcher has a built-in audio de-embedder which means the device is able to de-embed audio from its video ports to its analog audio output port.

ATTENTION! Audio can not be de-embedded from I1 to O3 as long as I5 is in use. This is due to the mutually exclusive operation of I1 and I5 ports. Embedded audio signal present will read false in the above case.

5.5.2. Dante® Audio Interface

DIFFERENCE: The following section refers to the UCX-4x2-HC30D model. *#new*

UCX-4x2-HC30D model contains a special module that allows de-embedding the audio stream of the incoming HDMI signal and transmitting as a 2-channel Dante® or AES67 source over the dedicated RJ45 connector. The chosen audio signal is mirrored to the analog audio port. *#dante #audio*

The same signal is sent to both analog and Dante audio outputs. Both can be muted at the same time by changing O3 port setting in the audio crosspoint: /MEDIA/AUDIO/XP/O3.Mute

The following command is exclusive to the analog port O3: /MEDIA/AUDIO/O3.Mute

Supported Audio

Input audio type	Signal support
2-ch LPCM **	supported
Multichannel	not supported
Compressed DTS/Dolby	not supported

** The supported sample rates are 44.1, 48, 88,2 and 96 kHz.

Dante® is a registered trademark of Audinate Pty Ltd.

Important Notes

- The AES67 mode is supported by the UCX-4x2-HC30D which can be set in the Dante® Controller software.
- Multichannel or encoded audio format cannot be de-embedded. In this case, no audio is sent to the Dante® network.

Settings and Signal Routing

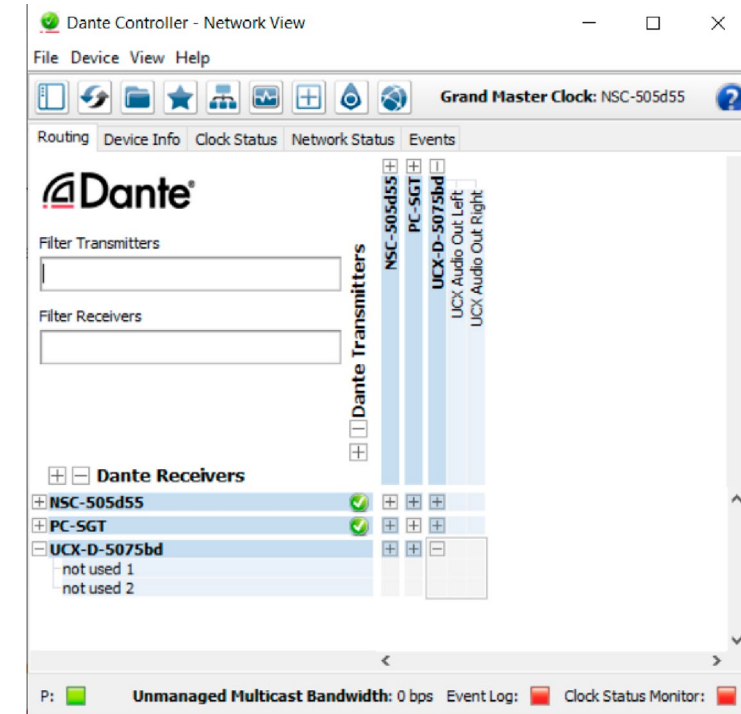

All these features are available in the Dante Controller software which can be downloaded from manufacturer's web page:

<https://www.audinate.com/products/software>

Device Settings

The discovered Dante®-compatible devices are displayed with middle-blue color. Double-click on the name to open the device settings.

The default device name is:

UCX-D-<Dante_MAC_address_last_6_characters>

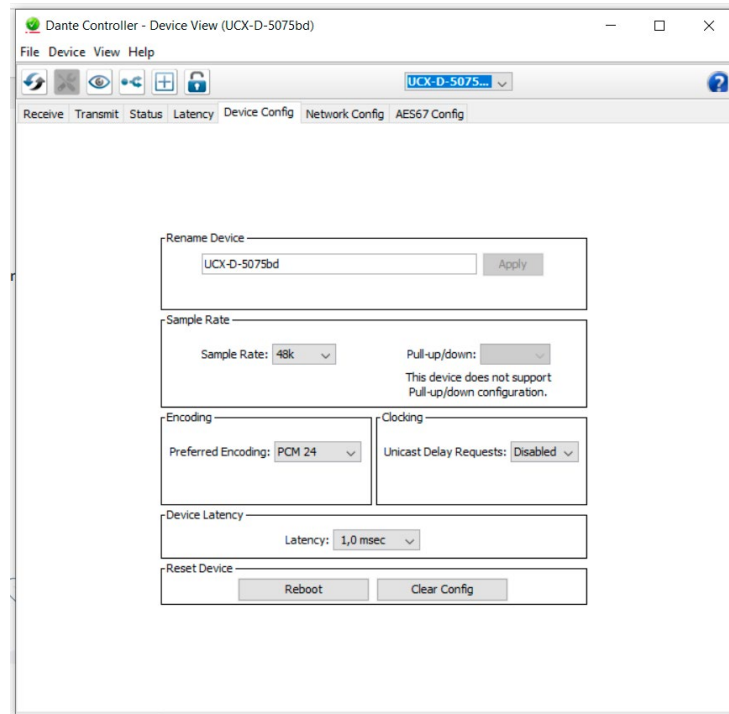

It can be changed under Device config tab. Similarly, the channel names can be also renamed. NSC-01 is another device with Dante® audio interface.



Press the  button to identify the device: the LEDs of the RJ45 connector will blink for six times in red.

5.6. Ethernet Interface

Summary of Ethernet ports

	USB-C	Ethernet
		
UCX-4x2-HC30	2x	3x

Ethernet Port Diagram

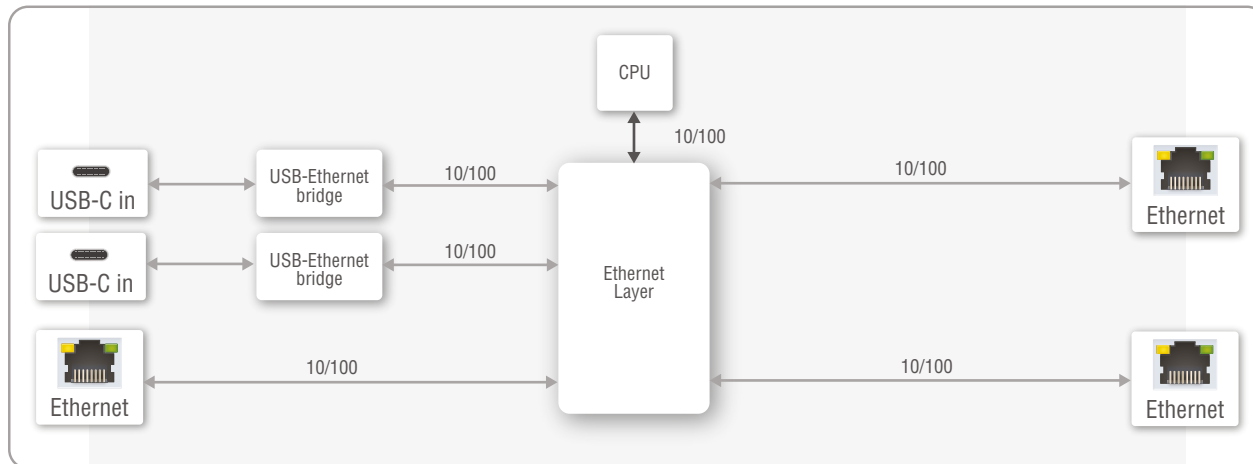

The device can be controlled via Ethernet (standard RJ45 connector). This interface supports:

- Configure the device with Lightware Device Controller. For more information about the LDC, see [Software Control - Lightware Device Controller](#) section.
- Control Lightware devices with LW3 command protocols. See more details about the Lightware protocol in the [LW3 Programmers' Reference](#) section.
- Establish the connection to Lightware Device Updater v2 software and perform Firmware Upgrade.
- Create local network, passthrough the Ethernet data traffic.

USB-Ethernet Bridge

The built-in USB-Ethernet bridge provides Ethernet for the USB-C connection. It is still available while the USB 3.1 Gen1 data channels are reserved for video or USB data transmission as it uses the USB-2.0 layer.

System Requirements of USB-Ethernet Bridge

The built-in USB-Ethernet bridge operates as a third-party USB Ethernet hub.

- Windows operation systems handle it plug and play.
- MacOS X operation systems require driver installation. Please find the driver on the following link: https://www.microchip.com/SWLibraryWeb/producttc.aspx?product=OBJ-LAN95xx-MAC_OS_X

ATTENTION! Enabling the third-party device operation is necessary (System Preferences -> Security & Privacy -> General -> Allow software driver from "Microchip").

- For the other operation systems, please find the driver on the following link: <https://www.microchip.com/wwwproducts/en/LAN9512>

6

Software Control - Lightware Device Controller

The device can be controlled by a computer through Ethernet by the Lightware Device Controller (LDC). The software can be installed on a Windows PC or macOS. The application and the User's Manual can be downloaded from www.lightware.com.

- ▶ INSTALL AND UPGRADE
- ▶ RUNNING THE LDC
- ▶ ESTABLISHING THE CONNECTION
- ▶ LDC LAYOUT
- ▶ VIDEO & AUDIO CROSSPOINT
- ▶ PORT PROPERTIES WINDOW
- ▶ USB CROSSPOINT
- ▶ EDID MENU
- ▶ CONTROL MENU
- ▶ ETHERNET
- ▶ SETTINGS MENU
- ▶ ADVANCED VIEW WINDOW

6.1. Install and Upgrade

INFO: After the installation, the Windows and the Mac application has the same look and functionality. This type of the installer is equal with the Normal install in case of Windows and results in an updatable version with the same attributes.

Installation for Windows OS

Run the installer. If the User Account Control drops a pop-up message click **Yes**.

During the installation you will be prompted to select the type of the installation: **normal** and the **snapshot** install:

Normal install	Snapshot install
Available for Windows and macOS	Available for Windows
The installer can update only this instance	Cannot be updated
Only one updatable instance can exist for all users	More than one different version can be installed for all users

Comparison of installation types

ATTENTION! Using the Normal install as the default choice is highly recommended.

Installation for macOS

Mount the DMG file with double clicking on it and drag the LDC icon over the Applications icon to copy the program into the Applications folder. If you want to copy the LDC into another location just drag the icon over the desired folder.

Upgrading of LDC

Step 1. Run the application.

The **Device Discovery** window appears automatically and the program checks the available updates on Lightware's website and opens the update window if LDC updates are found.

The current and the update version number can be seen at the top of the window and they are shown in this window even with the snapshot install.

The **Update** window can also be opened by clicking the **About icon** and the **Update** button.

Step 2. Set the desired update setting in the **Options** section.

- If you do not want to check for the updates automatically, uncheck **the circle**, which contains the green tick.
- If you want to postpone the update, a reminder can be set with different delays from the **drop down list**.
- If the proxy settings traverse the update process, set the proper values then click the **OK** button.

Step 3. Click the **Download update** button to start the upgrading.

The updates can be checked manually by clicking the **Check now** button.

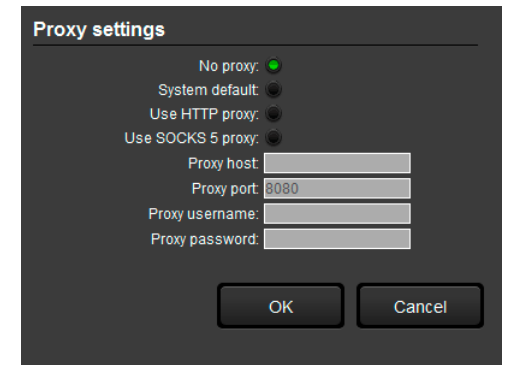

6.2. Running the LDC

The common way to start the software is double-click on the LDC icon. But the LDC can be run by command line parameters as follows:

Connecting to a Device with Static IP Address

The LDC is connected to a device with the indicated static IP address directly; the Device Discovery window is not displayed. When the port number is not set, the default port is used: 6107 (LW3 protocol).

Format: LightwareDeviceController -i <IP_address>:<port>

Example: LightwareDeviceController -i 192.168.0.20:6107

Adjusting the Zoom

The window can be zoomed to a specific value to fit to the resolution of the desktop (higher/lower). '1' is the default value (100%).

Format: LightwareDeviceController -z <magnifying_value>

Example: LightwareDeviceController -z 1.2

ATTENTION! The last set value is stored and applied when LDC is started without a parameter.

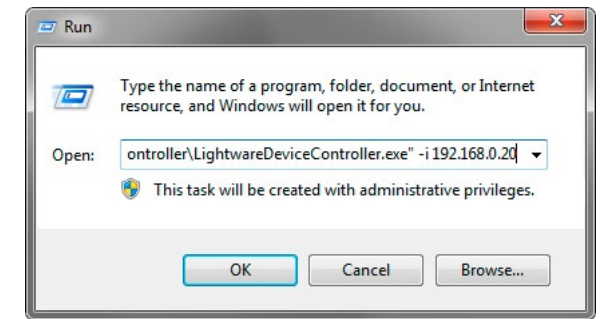

6.3. Establishing the Connection

Step 1. Connect the device to a computer via Ethernet.

Step 2. Run the controller software; device discovery window appears automatically.

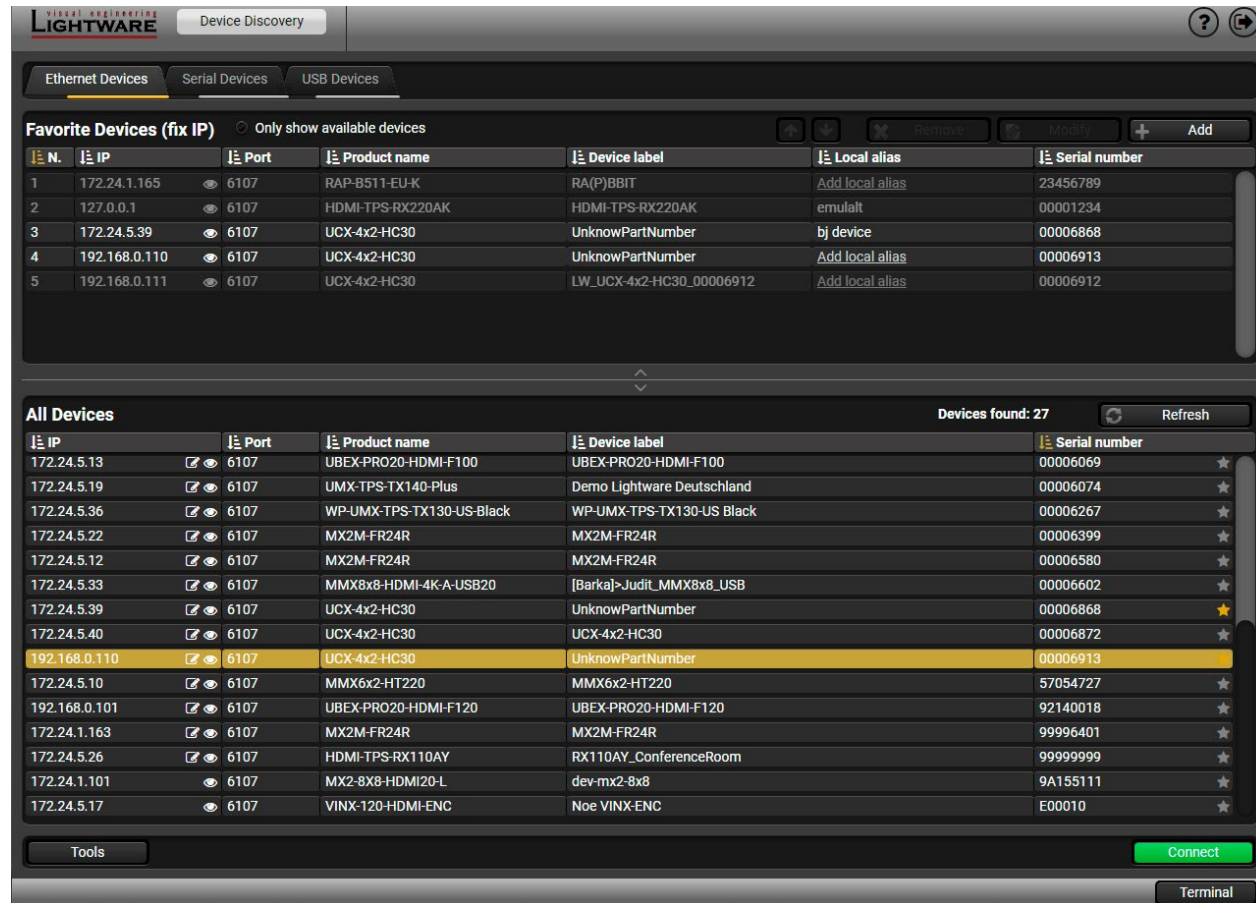

Device discovery window in LDC

Change IP Address

To modify IP address settings quickly it is not necessary to enter the device's settings/network menu, you can set them by clicking the pencil icon beside the IP address.

The actual settings are not indicated.

INFO: The factory default setting is DHCP, Static IP address can be set here. #ipaddress

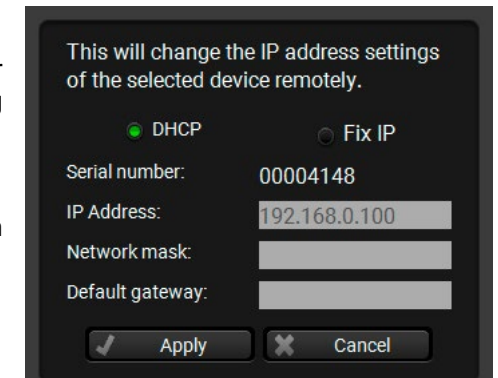

6.4. LDC Layout

ATTENTION! Up to the v1.0.1b1 firmware version and v2.5.3b3 LDC version, the older LDC layout can be seen. From the 1.1.0b7 firmware version and v2.5.4b3 LDC the LDC design changed as it is seen in this chapter. *#new*

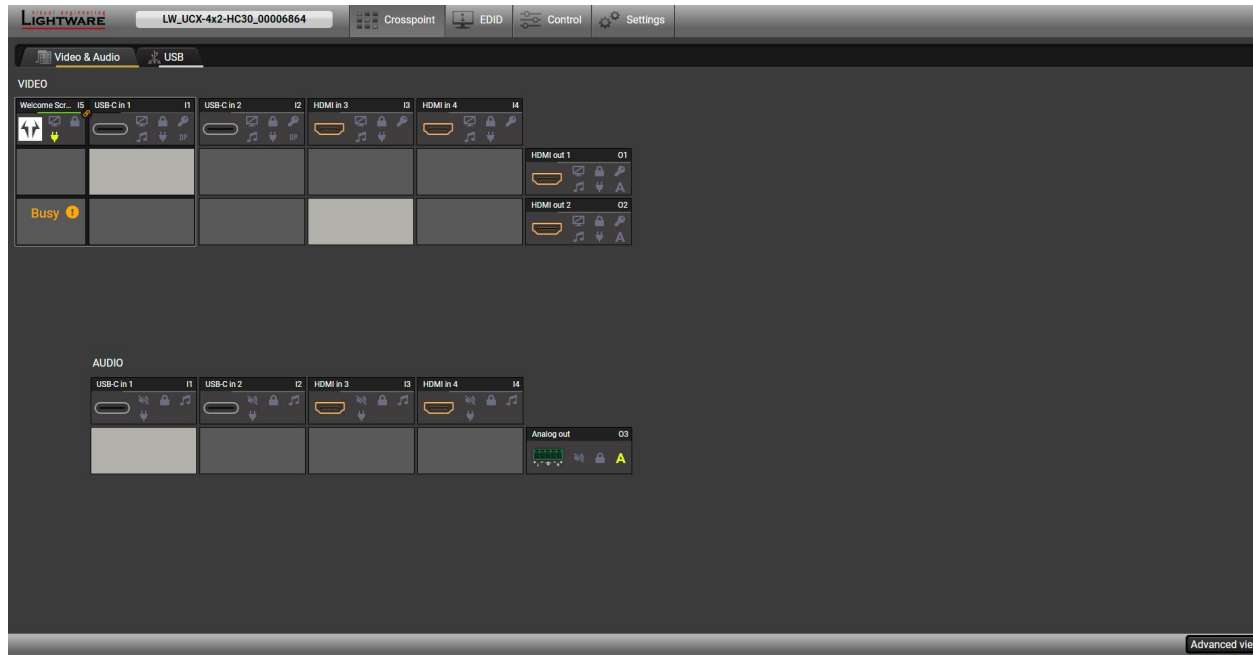

LDC design up to v2.5.3b3 LDC and v1.0.1b1 firmware

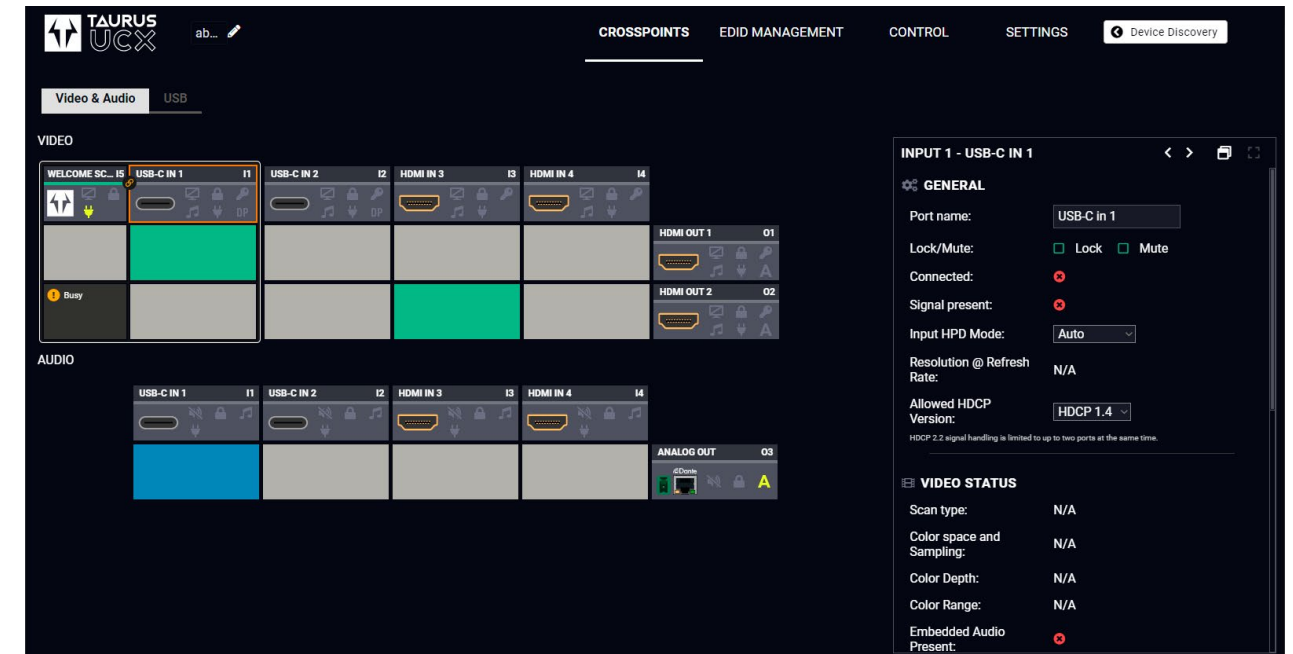

LDC design above v2.5.4b3 LDC and v 1.1.0b7 firmware

6.5. Video & Audio Crosspoint

#crosspoint #switch

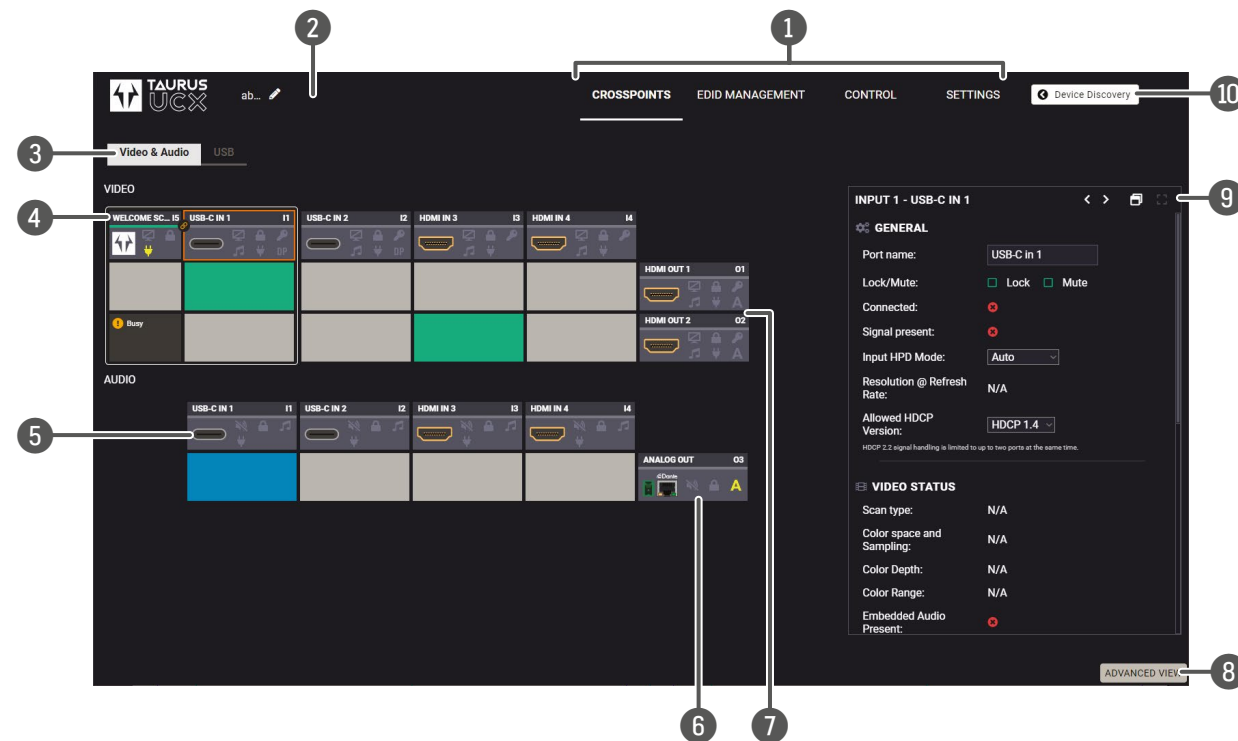

- 1 **Main menu** The available menu items are displayed. The active one is showed with dark grey background color.
- 2 **Information ribbon** The label shows the device label which can be edited in the Settings menu - [Status](#) tab.
- 3 **Submenu selector** The audio and video crosspoint menu and the USB crosspoint menu are available under the two tabs.
- 4 **Video input ports** Each tile represents a video input port: [Welcome Screen](#), [USB-C Inputs](#), [HDMI Video Inputs](#). The tile below the port shows the current crosspoint setting; if the port is switched to the output, the color of the tile is white, otherwise grey. Clicking on the tile opens the input properties window.
- 5 **Audio input ports** Each tile represents an audio input port. All of them are logical audio ports, they mean the de-embedded audio channel of the selected USB-C/HDMI inputs. For more details see [Embedded Audio Input](#).
- 6 **Audio output port** Analog audio output port; clicking on the O3 tile opens the [Analog Audio Output](#) window. The de-embedded audio is mirrored to the Dante Audio Output in case of UCX-4x2-HC30D.
- 7 **Video output ports** HDMI video output ports; clicking on the tile opens the [HDMI Video Output](#) port properties window.
- 8 **Advanced view** Displaying the [Advanced View Window](#), showing the Terminal window and the LW3 protocol tree.
- 9 **Properties window** Settings and status information of the selected panel are displayed in this section. Clicking on the icon  the properties section opens in new window.
- 10 **Navigation button** Device discovery window can be displayed by clicking on this button.

ATTENTION! Video crosspoint has a limitation: I1 and I5 ports are not available at the same time, only one of them can be selected to any output. **Busy** label on the crosspoint tile refers to the limitation. When I5 is selected for the video source, the de-embedded audio of the I1 is not available because of the video crosspoint limitation. For more details about it see the port diagram in [Audio Interface](#) section.

TIPS AND TRICKS: Hover the mouse cursor to the information ribbon; the **device label** and the **IP address** of the device will appear as a tooltip text.

6.5.1. Port Tiles

The colors of the port tiles and the displayed icons represent different states and information:

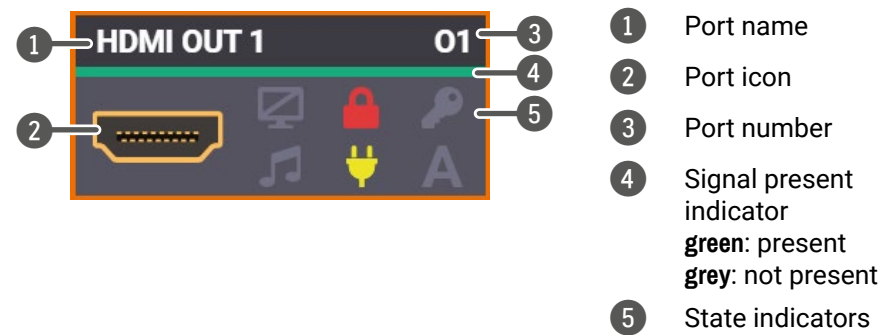

State Indicators *#lock #unlock #mute #unmute*

Following icons display different states of the port/signal:

Icon is grey	Description	Icon is highlighted	Description
	Port is unmuted		Port is muted
	Port is unlocked		Port is locked
	Signal is not encrypted with HDCP		Signal is encrypted with HDCP (the HDCP version is displayed)
	Embedded audio is not present		Embedded audio is present
	There is no connected device		The device is connected
DP	No USB Host connected or DP Alt mode is not supported by USB Host		DP Alternate mode successfully entered
			Unable to enter DP Alternate mode
A	Autoselect is disabled		Autoselect is enabled
	Audio is unmuted		Audio is muted
	Charging function is inactive		Charges the connected device

6.6. Port Properties Window

Clicking on the port tile opens the Port properties window. This section shows the available settings and status information by port types. `#lock #unlock #mute #unmute`

6.6.1. Welcome Screen

Welcome screen is an internal source which can be customized by uploading an image file. `#welcomescreen`

ATTENTION! Video crosspoint has a limitation: I1 and I5 ports are not available at the same time, only one of them can be selected to any output. **Busy** label on the crosspoint tile refers to the limitation.

INPUT 5 - WELCOME SCREEN

GENERAL

Port name: Welcome Screen

Lock/Mute: Lock Mute

WELCOME SCREEN SETTINGS

Display an image: Enable

Image:

Reset Image:

File date: 2020-11-04

File size: 657078 B

BMP or JPG Images with resolution 1280x720 are preferred. Maximum file size is 4MB. The last uploaded image will be used and previous images will be discarded.

Display a message: Enable

Message: Text Message

Allowed characters: Letters (A-Z, a-z), space (), hyphen (-), underscore (_), numbers (0-9), and dot (.). Max length: 63 characters.

General

Port name

The name of a port can be changed by typing the new name and clicking on the **Set** button. The following characters are allowed when naming: Letters (A-Z) and (a-z), hyphen (-), underscore (_), numbers (0-9), and dot (.). Max length: 63 characters.

Lock `#lock #unlock`

The port can be locked to the currently connected output ports by putting the tick. If the port is locked, the crosspoint state of this port cannot be changed.

Mute `#mute #unmute`

The welcome can be muted/unmuted by putting a tick. If the port is muted, no signal is transmitted from the input port.

Welcome Screen Settings

Display Welcome Screen Image

Put a tick to **Display Welcome Screen Image** to enable the appearance of the internal image.

Upload Image

Click to the **Upload Image** Button to browse jpg or bmp file to customize the welcome screen picture. Recommended resolution: 1280x720 pixel, maximum file size is 4MB.

ATTENTION! Uploading a new image will overwrite the previous one.

Reset Image

Clicking on reset image button restores the factory default state.

Display Welcome Screen Message

Put a tick to **Display Welcome Screen Message** to enable the appearance of the text message.

Welcome Screen Message

The following characters are allowed: Letters (A-Z) and (a-z), hyphen (-), underscore (_), numbers (0-9), space () and dot (.). Max length: 63 characters.

6.6.2. USB-C Inputs

Clicking on the USB-C video input port icon results opening the Port properties window. The most important information and settings are available from the panel.

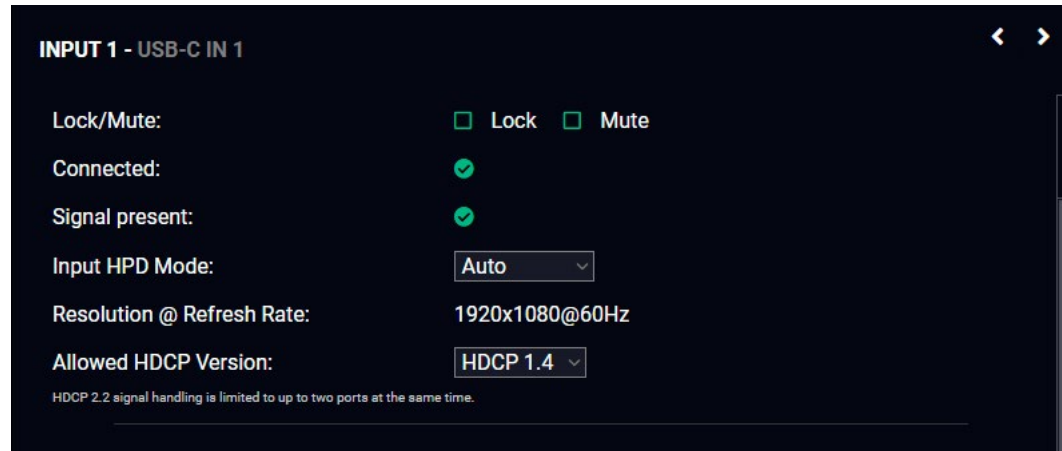

USB-C input port properties window

General

Port name

The name of a port can be changed by typing the new name and clicking on the **Set** button. The following characters are allowed when naming: Letters (A-Z) and (a-z), hyphen (-), underscore (_), numbers (0-9), and dot (.). Max length: 63 characters.

Lock *#lock #unlock*

The port can be locked to the currently connected output ports by putting the tick. If the port is locked, the crosspoint state of this port cannot be changed.

Mute *#mute #unmute*

The incoming signal can be muted/unmuted by putting a tick. If the port is muted, no signal is transmitted from the input port.

Status information

Connected / Signal Presence / Resolution

Allowed HDCP Version *#hdcv*

ATTENTION! HDCP 2.2 signal handling is limited up to two input ports at the same time.

- **Off:** The connected source will detect that the switcher is not HDCP-compliant and turn off authentication if the content allows it.
- **HDCP 1.4:** The connected source will detect that the switcher is compliant with HDCP 1.4 but not compliant with HDCP 2.2.
- **HDCP 2.2:** The connected source will detect that the switcher is compliant with HDCP 2.2.

Video Status

This section gives a feedback about the current video stream:

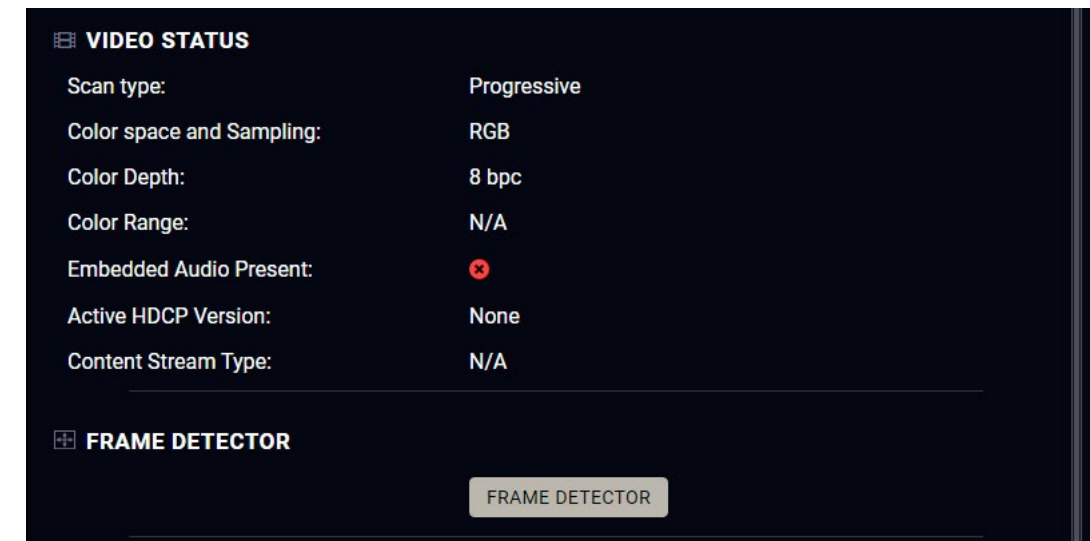

USB-C input port properties window

Frame detector

For more details see [Frame Detector](#) section.

DisplayPort Link

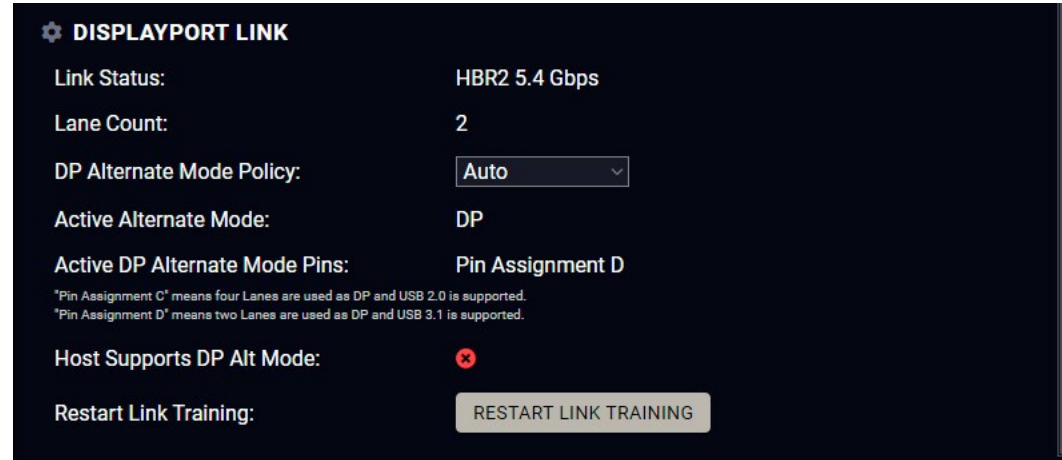

USB-C input port properties window

INFO: The USB-C source sends Displayport video signal, so the video setting options of the USB-C port are similar to the DisplayPort. The UCX-4x2-HC30 converts DP signal to HDMI internally.

DP Alternate Mode Policy

The following parameters can be set:

The two different signals (video and USB 3.x) can be transmitted at the same time with shared bandwidth. This case DP video reserves 2x Superspeed Channels for the video signal in alternate mode and there are 2x Superspeed Channels for USB 3.x.

- **Auto:** Taurus offers both operation modes described below. BYOD device can choose between the two. Neither USB3, nor 4 lane DP Alt mode operation (4K@60) is guaranteed. BYOD devices supporting USB3.x usually choose shared mode: USB3.1 and 2 lane DP.
- **Prefer video:** Uses 4 Lanes for Displayport video, in this case USB 3.x data transmission does not operate.
- **Prefer USB 3.1:** The two different signals (DP video and USB 3.x) can be transmitted at the same time with shared bandwidth. DP video reserves 2 Lanes.

Restart Link Training *#linktraining*

Link training is a process where the source (PC, laptop, media server) and the sink (switcher) agree on a data rate, lane count and electrical parameters. The successful link training is a pre-requisite of the video transmission. If the quality of the USB cable is insufficient to reliably handle higher data rates, link training will result in a lower data rate where stable connection between the source and the switcher can be maintained.

Clicking on the **Restart Link Training** button starts to build up the connection again between the switcher and the source (it happens automatically when the source is connected). It is equal with unplug and reconnect the Type-C connector.

6.6.3. HDMI Video Input

Clicking on the HDMI video input port icon results opening the Port properties window. The most important information and settings are available from the panel.

INPUT 3 - HDMI IN 3

GENERAL

Port name: HDMI in 3

Lock/Mute: Lock Mute

Connected:

Signal present:

Input HPD Mode: Auto

Resolution @ Refresh Rate: 1920x1200@60Hz

Allowed HDCP Version: HDCP 2.2

HDCP 2.2 signal handling is limited to up to two ports at the same time.

VIDEO STATUS

Scan type: Progressive

Color space and Sampling: RGB

Color Depth: 8 bpc

Color Range: N/A

Embedded Audio Present:

Active HDCP Version: None

Content Stream Type: N/A

FRAME DETECTOR

FRAME DETECTOR

Port properties window of the HDMI video input

Available settings and tools

Port name

The name of a port can be changed by typing the new name and clicking on the **Set** button. The following characters are allowed when naming: Letters (A-Z) and (a-z), hyphen (-), underscore (_), numbers (0-9), and dot (.). Max length: 63 characters.

Lock *#lock #unlock*

The port can be locked to the currently connected output ports by putting the tick. If the port is locked, the crosspoint state of this port cannot be changed.

INFO: When the locked input was switched to the output, the crosspoint state can not be changed and all inputs are locked in that line.

Mute *#mute #unmute*

The incoming signal can be muted/unmuted by putting a tick. If the port is muted, no signal is transmitted from the input port.

Allow HDCP Version *#hdcv*

ATTENTION! HDCP 2.2 signal handling is limited up to two input ports at the same time.

- **Off:** The connected source will detect that the switcher is not HDCP-compliant and turn off authentication if the content allows it.
- **HDCP 1.4:** The connected source will detect that the switcher is compliant with HDCP 1.4 but not compliant with HDCP 2.2.
- **HDCP 2.2:** The connected source will detect that the switcher is compliant with HDCP 2.2.

Frame detector

For more details see [Frame Detector](#) section.

6.6.4. HDMI Video Output

OUTPUT 2 - HDMI OUT 2
◀ ▶

GENERAL

Port name:

Lock/Mute: Lock Mute

Connected: ✔

Signal present: ✔

HDCP Mode:

VIDEO STATUS

Scan type: Progressive

Color space and Sampling: RGB

Color Depth: 8 bpc

Color Range: N/A

Active HDCP Version: None

Content Stream Type: N/A

HDCP Status: N/A

Resolution @ Refresh Rate: 1920x1200@60Hz

AUDIO STATUS

Embedded Audio Present: ✘

Audio Sampling frequency: N/A

Audio Signal type: N/A

OUTPUT OPTIONS

Output 5V Enable:

Output Signal Type:

Embedded Audio Mute: Mute

Port properties window of the HDMI video output

Available settings and tools

General

Port name

The name of a port can be changed by typing the new name and clicking on the **Set** button. The following characters are allowed when naming: Letters (A-Z) and (a-z), hyphen (-), underscore (_), numbers (0-9), and dot (.). Max length: 63 characters.

Lock *#lock #unlock*

The port can be locked to the currently connected output ports by putting the tick. If the port is locked, the crosspoint state of this port cannot be changed.

Mute *#mute #unmute*

The incoming signal can be muted/unmuted by putting a tick. If the port is muted, no signal is transmitted from the input port.

HDCP Mode *#hdc*

- **HDCP mode:** Auto / Always - The transmitter forces the source sent the signal without encryption if the content allows when Auto mode is selected; *#signaltype #hdc*

Output Options

Output 5V Enable

- Auto / On / Off - The setting lets the source and the sink devices be connected – independent from the transmitted signal.

Output Signal Type

- Auto / DVI - The outgoing signal format can be selected by a drop-down menu.

Embedded Audio Mute

Put a tick to turn off the embedded audio.

Frame detector

For more details see [Frame Detector](#) section.

Autoselect

Autoselect feature makes possible switching input to the output without human intervention. The crosspoint state changes the based on the active input signals.

Three operation policy can be set: *#autoselect #videoautoselect*

Disable autoselect: crosspoint state change happens manually.

First detect: selected input port is kept connected to the output as long as it has an active signal.

Last detect mode: always the last attached input is selected to transmit.

Individual input settings: always the highest priority active input is selected to transmit (1- highest priority, 100- lowest priority).

Pay attention for the following settings for the proper operation of the Autoselect function:

- Be sure that all priority values are filled in;
- Be sure that all inputs are enabled with the green tick on the right side;
- Always click on the **Apply autoselect settings** button after the changes to launch the new settings.

See more details about the feature in [The Autoselect Feature](#) section.

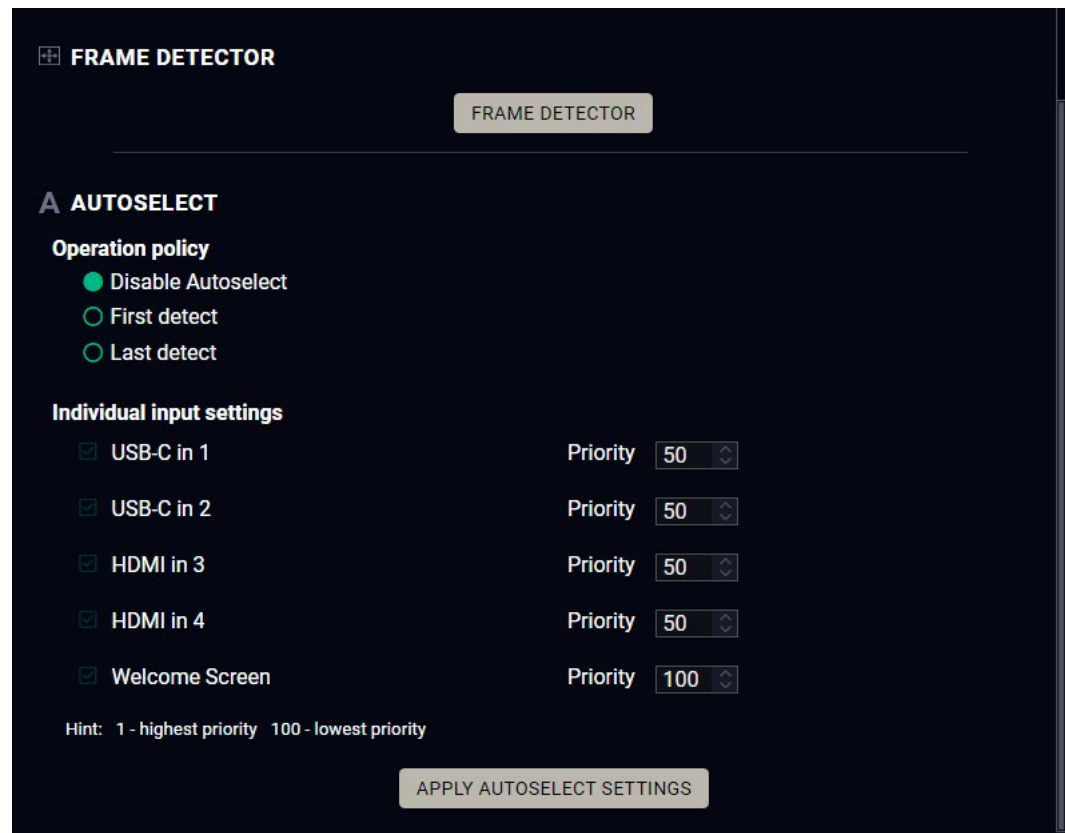

6.6.5. Embedded Audio Input



Port properties window of the audio input

Available settings

Port name

The name of a port can be changed by typing the new name and clicking on the **Set** button. The following characters are allowed when naming: Letters (A-Z) and (a-z), hyphen (-), underscore (_), numbers (0-9), and dot (.). Max length: 63 characters.

Lock *#lock #unlock*

The port can be locked to the currently connected output ports by putting the tick. If the port is locked, the crosspoint state of this port cannot be changed.

Mute *#mute #unmute*

The incoming signal can be muted/unmuted by putting a tick. If the port is muted, no audio signal is transmitted from the input port.

ATTENTION! Video crosspoint has a limitation: I1 and I5 ports are not available at the same time, only one of them can be selected to any output. When I5 is selected for video source, the de-embedded audio of the I1 is not available because of the video crosspoint limitation. For more details about it see the port diagram in [Audio Interface](#) section.

6.6.6. Analog Audio Output

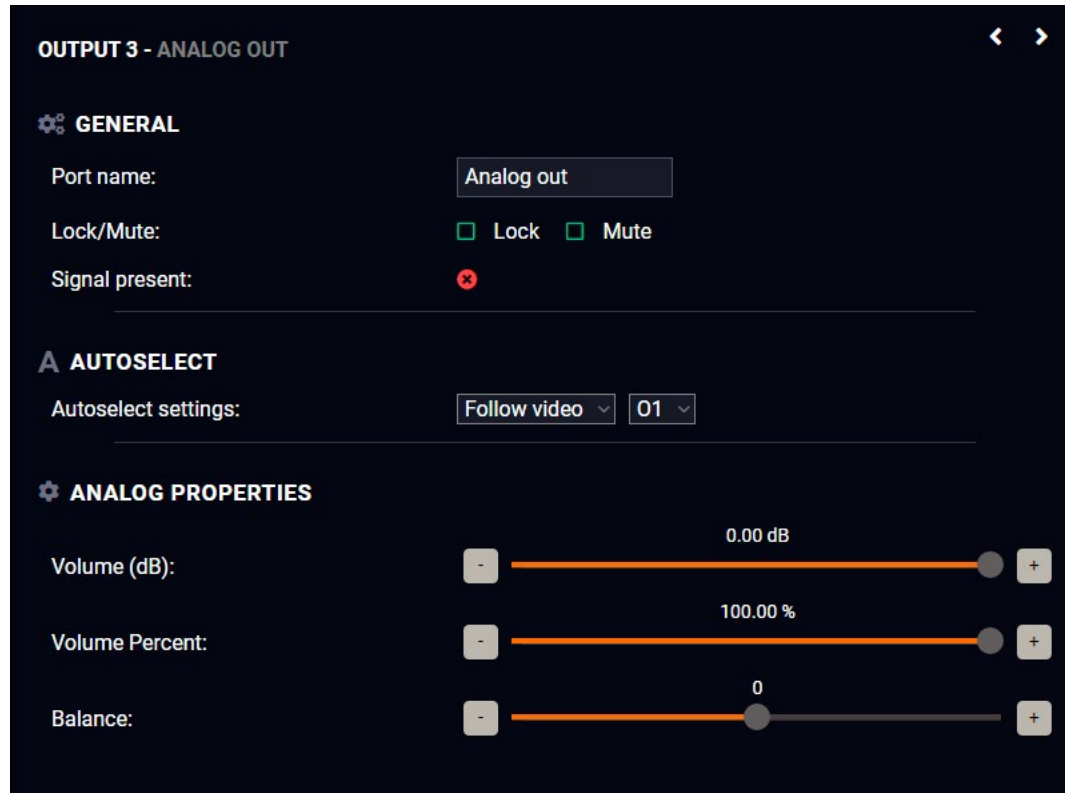

Port properties window of the analog audio output

Available settings: [#analogaudio](#) [#volume](#) [#balance](#)

- Port name
- Mute/unmute the port;
- Lock/unlock the port;
- Autoselect settings: off / follow video (O1 or O2). Follow video option means, that the audio of the selected video input will be switched to the analog audio output. When the video crosspoint changes, audio crosspoint follows it.
- Volume: from 100 to 0%, in step 1% (0 dB to -95.625 dB, in step 0.375 dB (default is 0 dB));
- Balance: from -100 to +100, in step 1 (default is 0 = center).

INFO: The de-embedded audio is mirrored to the Dante Audio Output in case of UCX-4x2-HC30D.

6.6.7. Frame Detector

The ports can show detailed information about the signal like full size and active video resolution. This feature is a good troubleshooter if compatibility problems occur during system installation. To access this function, open the port properties window and click on **Frame detector** button. [#framedetector](#)

Hres	Vres	Act. px	Act. In	Vbporch	Vfporch	Hbporch	Hfporch	Hsyncw	Vfreq	Hfreq	PxClk	TMDSClk
0 pixels	0 lines	0 pixels	0 lines	0 lines	0 lines	0 pixels	0 pixels	0 pixels	0 Hz	0 kHz	0 MHz	0 MHz
0 pixels	0 lines	0 pixels	0 lines	0 lines	0 lines	0 pixels	0 pixels	0 pixels	0 Hz	0 kHz	0 MHz	0 MHz
2200 pixels	1125 lines	1920 pixels	1080 lines	36 lines	4 lines	148 pixels	88 pixels	44 pixels	60 Hz	67.5 kHz	148 MHz	148 MHz
2200 pixels	1125 lines	1920 pixels	1080 lines	36 lines	4 lines	148 pixels	88 pixels	44 pixels	60 Hz	67.5 kHz	148 MHz	148 MHz
2200 pixels	1125 lines	1920 pixels	1080 lines	36 lines	4 lines	148 pixels	88 pixels	44 pixels	60 Hz	67.5 kHz	148 MHz	148 MHz
0 pixels	0 lines	0 pixels	0 lines	0 lines	0 lines	0 pixels	0 pixels	0 pixels	0 Hz	0 kHz	0 MHz	0 MHz

Frame Detector Window

Lightware's Frame Detector function works like a signal analyzer and makes possible to determine the exact video format that is present on the port, thus helps to identify many problems. E.g. actual timing parameters may differ from the expected and this may cause some displays to drop the picture.

Frame Detector measures detailed timings on the video signals just like a built-in oscilloscope, but it is much more easy to use. Actual display area shows the active video size (light grey). Dark grey area of the full frame is the blanking interval which can contain the info frames and embedded audio data for HDMI signals. Shown values are measured actually on the signal and not retrieved only from the HDMI info frames.

6.7. USB Crosspoint

In USB crosspoint tab, the connection between the of the upstream ports (USB-C and USB-B ports) and the USB hub (USB-A ports) can be set. `#usb #usbc`

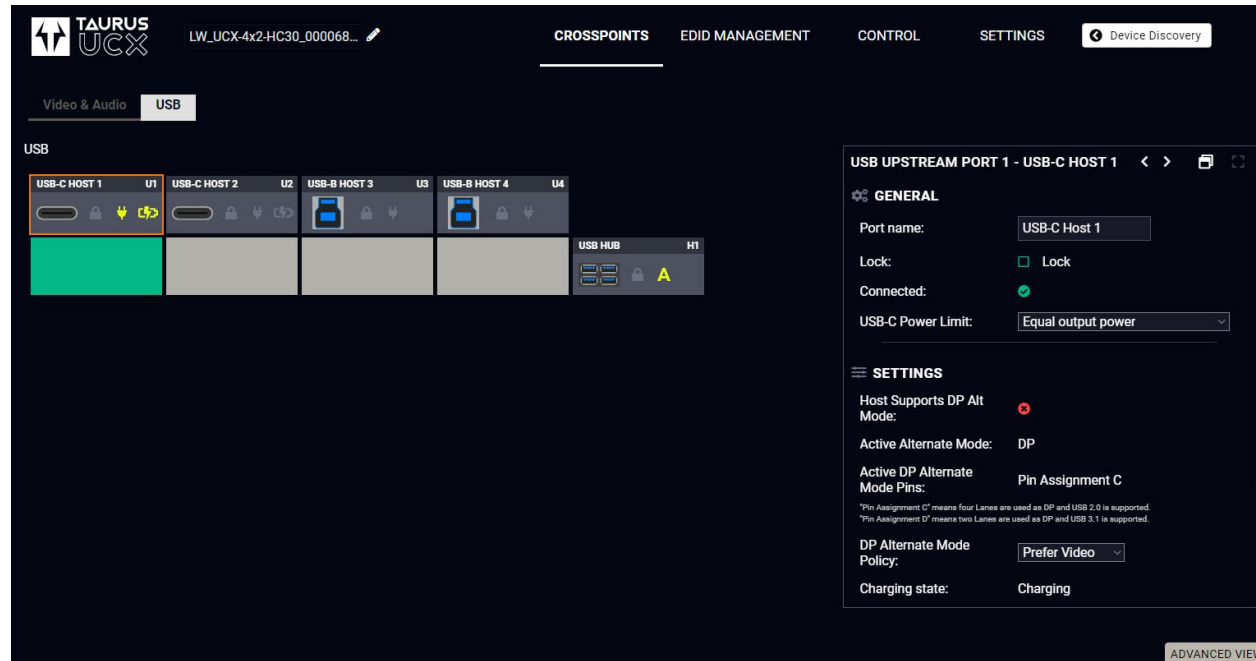

6.7.1. USB-C Port Properties

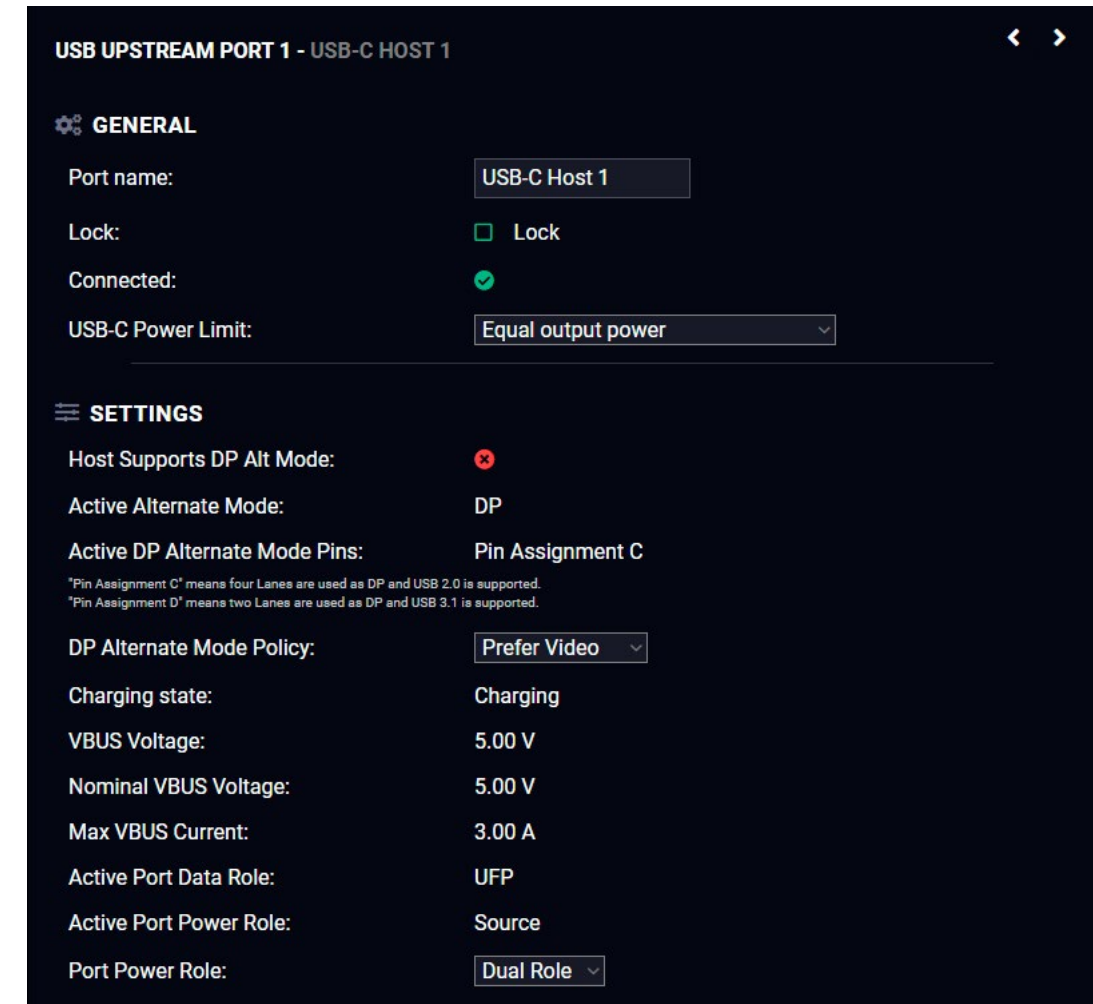

Available settings and tools

General

Port name

The name of a port can be changed by typing the new name and clicking on the **Set** button. The following characters are allowed when naming: Letters (A-Z) and (a-z), hyphen (-), underscore (_), numbers (0-9), and dot (.). Max length: 63 characters.

Lock `#lock #unlock`

The port can be locked to the currently connected output ports by putting the tick. If the port is locked, and the crosspoint state of this port cannot be changed.

USB-C Power Limit

Choose a powering option from the drop-down menu: *#power*

- **Equal output power:** both USB-C ports supplies max. 30W power.
- **Port 1 maximum, Port 2 minimum:** U1port supplies max. 60W power, U2 port supplies 5V/3A.
- **Port 2 maximum, Port 1 minimum:** U2port supplies max. 60W power, U1 port supplies 5V/3A.

Settings

DP Alternate Mode Policy

This is equal with the [DP Alternate Mode Policy](#) setting on the USB-C video port. *#dpaltnode #alternatemode #displayportalternatemode*

Power Role

Dual role: The switcher can be source (and sends power to the connected device) or sink (the switcher does not send power, real power consumption does not happen) depending on the connected device.

INFO: Using **Dual role** setting is highly recommended, the other options are mainly for troubleshooting.

Source: When the connected device is a sink (e.g. smart phone or a dual-role laptop), the switcher charges it via the USB-port.

Sink: When the power role of the connected device is source-only (e.g. PC), the switcher has to change its power role (sink or dual-role) to build up the connection. Real power consumption does not happen.

6.7.2. USB-B Port Properties



Available settings and tools *#usb #usbc*

Port name

The name of a port can be changed by typing the new name and clicking on the **Set** button. The following characters are allowed when naming: Letters (A-Z) and (a-z), hyphen (-), underscore (_), numbers (0-9), and dot (.). Max length: 63 characters.

Lock *#lock #unlock*

The port can be locked to the currently connected output ports by putting the tick. If the port is locked, the crosspoint state of this port cannot be changed.

USB Hub Properties

USB HUB DOWNSTREAM PORT 1 - USB HUB

GENERAL

Port name:

Lock: Lock

USB DEVICES

D1 Power 5V Mode:

D2 Power 5V Mode:

D3 Power 5V Mode:

D4 Power 5V Mode:

AUTOSELECT

Operation policy

Disable Autoselect

Follow video

First detect

Last detect

Follow video port setting:

Individual input settings

Host	Priority
<input checked="" type="checkbox"/> USB-C Host 1	<input type="text" value="50"/>
<input checked="" type="checkbox"/> USB-C Host 2	<input type="text" value="50"/>
<input checked="" type="checkbox"/> USB-B Host 3	<input type="text" value="50"/>
<input checked="" type="checkbox"/> USB-B Host 4	<input type="text" value="50"/>

Hint: 1 - highest priority 100 - lowest priority

Available settings and tools

General

Port name

The name of a port can be changed by typing the new name and clicking on the **Set** button. The following characters are allowed when naming: Letters (A-Z) and (a-z), hyphen (-), underscore (_), numbers (0-9), and dot (.). Max length: 63 characters.

Lock *#lock #unlock*

The port can be locked to the currently connected output ports by putting the tick. If the port is locked, the crosspoint state of this port cannot be changed.

Autoselect *#autoselect #usbautoselect #new*

For more details about this feature see [Autoselect](#) section.

Autoselect settings: Disable autoselect / Follow video / First detect / Last detect mode / Individual input settings

Follow video (O1 or O2): Follow O2 means the same computer will be the video source for O2 output and the USB Host of all USB downstream devices.

Video and USB ports either have a common USB Type-C connector for each port, or an HDMI and USB-B are clearly marked to belong together as one port.

USB Devices

Power 5V Mode can be set for each port in the drop-down menu: When the option is **Off** the switcher does not send device 5V over the USB-A port. Using **Auto** mode is recommended.

6.8. EDID Menu

Advanced EDID Management can be accessed by selecting the EDID menu. There are two panels: left one contains Source EDIDs, right one contains Destination places where the EDIDs can be emulated or copied.

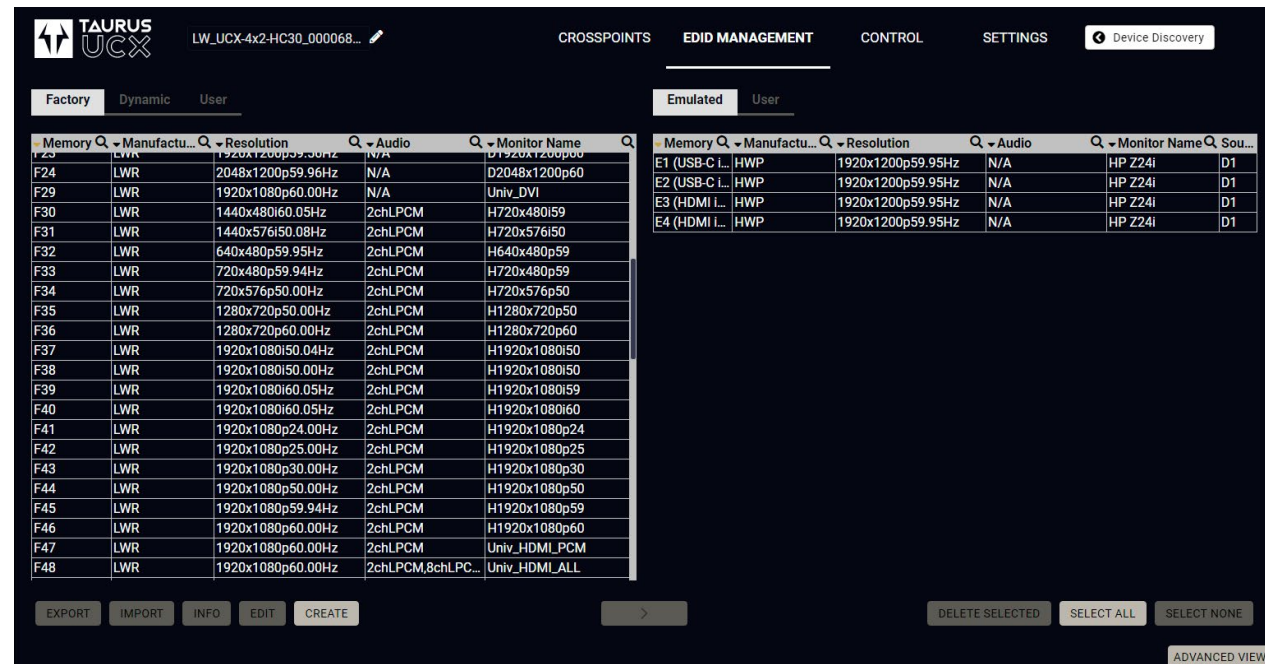

EDID Menu

Control Buttons

- EXPORT

Exporting an EDID (save to a file)

➤

Transfer button: executing EDID emulation or copying
- IMPORT

Importing an EDID (load from a file)

DELETE SELECTED

Deleting EDID (from User memory)
- INFO

Display EDID Summary window

SELECT ALL

Selecting all memory places in the right panel
- EDIT

Opening Advanced EDID Editor with the selected EDID

SELECT NONE

Selecting none of the memory places in the right panel
- CREATE

Opening Easy EDID Creator

#edid

6.8.1. EDID Operations

Changing Emulated EDID

- Step 1.** Choose the desired **EDID list** on the source panel and select an **EDID**. ➤
- Step 2.** Press the **Emulated** button on the top of the Destination panel.
- Step 3.** Select the desired **port** on the right panel (one or more ports can be selected); the EDID(s) will be highlighted with a yellow cursor.
- Step 4.** Press the **Transfer** button to change the emulated EDID.

Learning an EDID

The process is the same as changing the emulated EDID; the only difference is the Destination panel: press the **User** button. Thus, one or more EDIDs can be copied into the user memory either from the factory memory or from a connected sink (Dynamic).

Exporting an EDID

- Source EDID can be downloaded as a file (*.bin, *.dat or *.edid) to the computer.
- Step 1.** Select the desired **EDID** from the Source panel (line will be highlighted with yellow).
 - Step 2.** Press the **Export** button to open the dialog box and save the file to the computer.

Importing an EDID

- Previously saved EDID (*.bin, *.dat or *.edid file) can be uploaded to the user memory: IMPORT
- Step 1.** Press the **User** button on the top of the Source panel and select a **memory** slot.
 - Step 2.** Press the **Import** button below the Source panel.
 - Step 3.** Browse the file in the opening window then press the **Open** button. Browsed EDID is imported into the selected User memory.

ATTENTION! The imported EDID overwrites the selected memory place even if it is not empty.

Deleting EDID(s)

- The EDID(s) from User memory can be deleted as follows: DELETE SELECTED
- Step 1.** Press **User** button on the top of the Destination panel.
 - Step 2.** Select the desired **memory** slot(s); one or more can be selected (“Select All” and “Select None” buttons can be used). The EDID(s) will be highlighted with yellow.
 - Step 3.** Press the **Delete selected** button to delete the EDID(s).

6.8.2. EDID Summary Window

Select an EDID from Source panel and press **Info** button to display EDID summary.

INFO

General

- Power Management
- Gamma / Colors
- Established Timings
- Standard Timings
- Preferred Timing Mode
- 2nd Descriptor Field
- 3rd Descriptor Field
- 4th Descriptor Field
- CEA General
- CEA Video
- CEA Audio
- CEA Speaker Allocation
- CEA HDMI VSDB
- CEA HDMI Forum VSDB
- CEA YCbCr 4:2:0 VDB
- CEA YCbCr 4:2:0 Capability Map
- CEA Colorimetry
- CEA High Dynamic Range
- CEA Detailed Timing Descriptors
- DisplayID General
- DisplayID Product ID
- DisplayID Type I Timing #1
- DisplayID Type I Timing #2
- DisplayID Type I Timing #3
- DisplayID Tiled Display Topology
- DisplayID Unknown Blocks

General

- EDID version: 1
- EDID revision: 4
- Manufacturer ID: LWR (Lightware Visual Engineering)
- Product ID: 0000
- Monitor serial number: Not present
- Year of manufacture: 2010
- Week of manufacture: Not Used
- Signal interface: Digital
- Separate Sync H&V: -
- Composite sync on H: -
- Sync on green: -
- Serration on VS: -
- Color depth: Undefined
- Interface standard: HDMI-a is supported
- Color spaces: RGB 4:4:4 & YCbCr 4:4:4
- Aspect ratio: 0
- Display size: 0 cm X 0 cm

EDID Summary Window

6.8.3. Editing an EDID

Select an EDID from Source panel and press **Edit** button to display Advanced EDID Editor window. The editor can read and write all descriptors, which are defined in the standards, including the additional CEA extensions. Any EDID from the device's memory or a saved EDID file can be loaded into the editor. The software resolves the raw EDID and displays it as readable information to the user. All descriptors can be edited, and saved in an EDID file, or uploaded to the User memory. For more details about EDID Editor please visit our website (www.lightware.com) and download the EDID Editor Application note.

EDIT

Basic EDID

- Vendor / Product Information
- Display Parameters
- Power Management and Features
- Gamma / Color and Established Timings
- Standard Timings
- Preferred Timing Mode
- 2nd Descriptor Field
- 3rd Descriptor Field
- 4th Descriptor Field
- CEA Extension
- General
- Video Data
- Audio Data
- Speaker Allocation Data
- HDMI VSDB
- HDMI Forum VSDB
- YCbCr 4:2:0 VDB
- YCbCr 4:2:0 Capability Map
- Colorimetry
- High Dynamic Range
- Detailed Timing Descriptor #1
- Detailed Timing Descriptor #2
- Detailed Timing Descriptor #3
- Detailed Timing Descriptor #4
- Detailed Timing Descriptor #5
- Detailed Timing Descriptor #6
- Display ID Extension
- Product ID

EDID Byte Editor

	0	1	2	3	4	5	6	7	8	9
0	00	FF	FF	FF	FF	FF	FF	00	32	F2
10	00	00	00	00	00	00	00	14	01	04
20	82	00	00	78	0F	EE	91	A3	54	4C
30	99	26	0F	50	54	FF	FF	80	61	40
40	81	C0	81	00	81	80	81	8F	A9	40
50	D1	C0	D1	00	04	74	00	30	F2	70
60	5A	80	B0	58	8A	00	00	70	F8	00
70	00	1E	02	3A	80	18	71	38	2D	40
80	58	2C	45	00	80	38	74	00	00	1E
90	00	00	00	FD	00	0F	78	0F	FF	1E
100	04	11	30	00	F8	38	F0	1E	00	00
110	00	FC	00	55	6E	69	76	5F	34	6B
120	5F	41	4C	4C	0A	20	01	24		

EDID Editor Window

6.8.4. Creating an EDID - Easy EDID Creator

Since above mentioned Advanced EDID Editor needs more complex knowledge about EDID, Lightware introduced a wizard-like interface for fast and easy EDID creation. With Easy EDID Creator it is possible to create custom EDIDs in four simple steps. By clicking on the **Create** button below Source panel, **Easy EDID Creator** is opened in a new window. For more details about EDID Editor please visit our website (www.lightware.com) and download the EDID Editor Application note.

CREATE

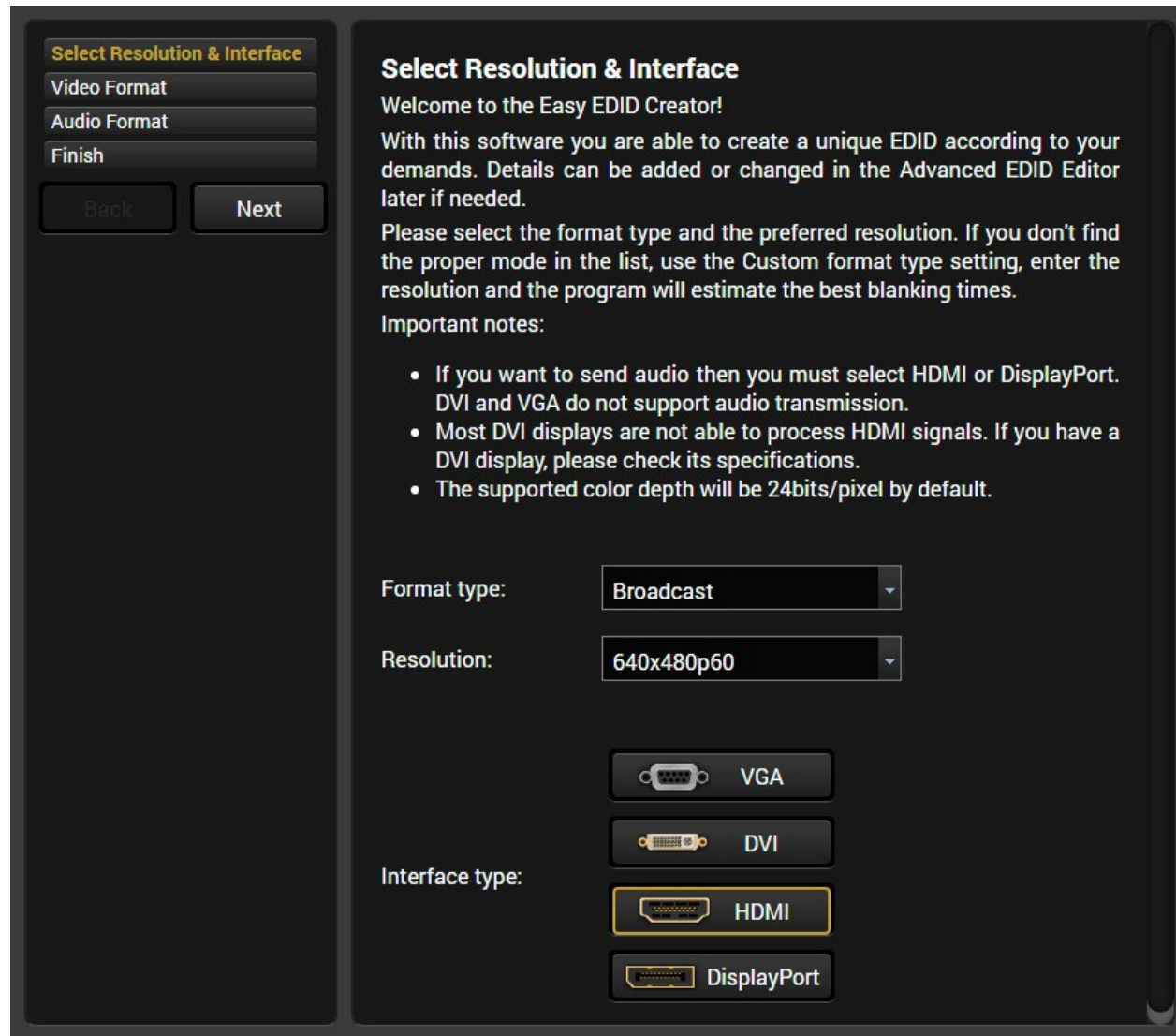

EDID Creator Window

6.9. Control Menu

6.10. Ethernet

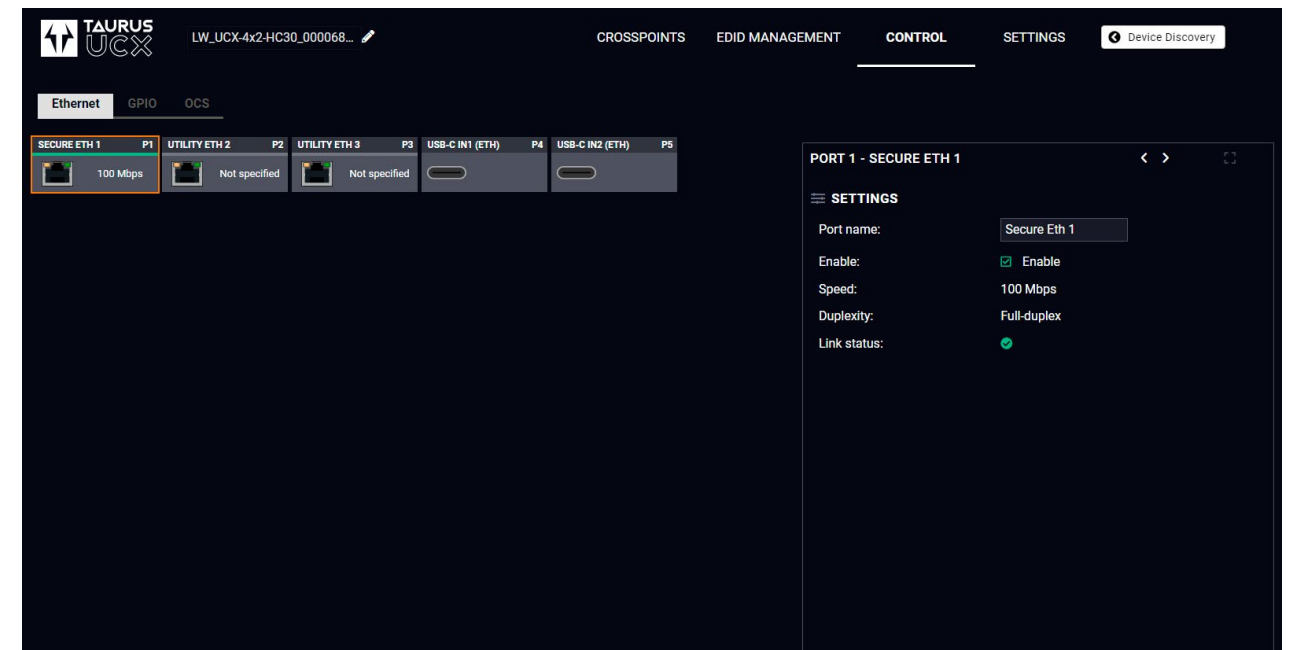

Ethernet tab in Control menu

Five ports are displayed in the Ethernet settings: Three of them belong to the RJ-45 Ethernet connectors. You can check the status of the Ethernet line by each ports: the speed and the duplexity of the connection. The remaining two are for configuring the Ethernet layer in the USB-C ports.

The following settings are available for each ports:

- Rename the port
- Enable / disable the port;

6.10.1. GPIO

DIFFERENCE: This feature is available only from FW package 1.1.0b7.

The GPIO port has 6 pins, which operate at TTL digital signal levels and can be controlled by LDC or protocol commands. Select a GPIO pin under the Port settings section; the settings (pin direction and input level) are displayed on the port tiles as well. *#gpio #new*

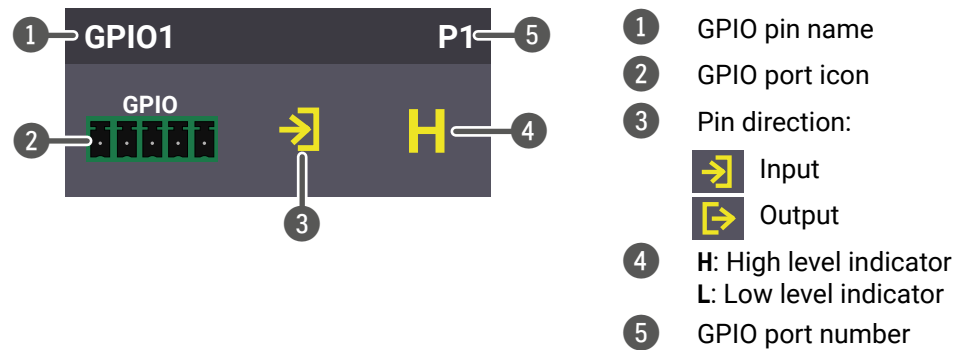
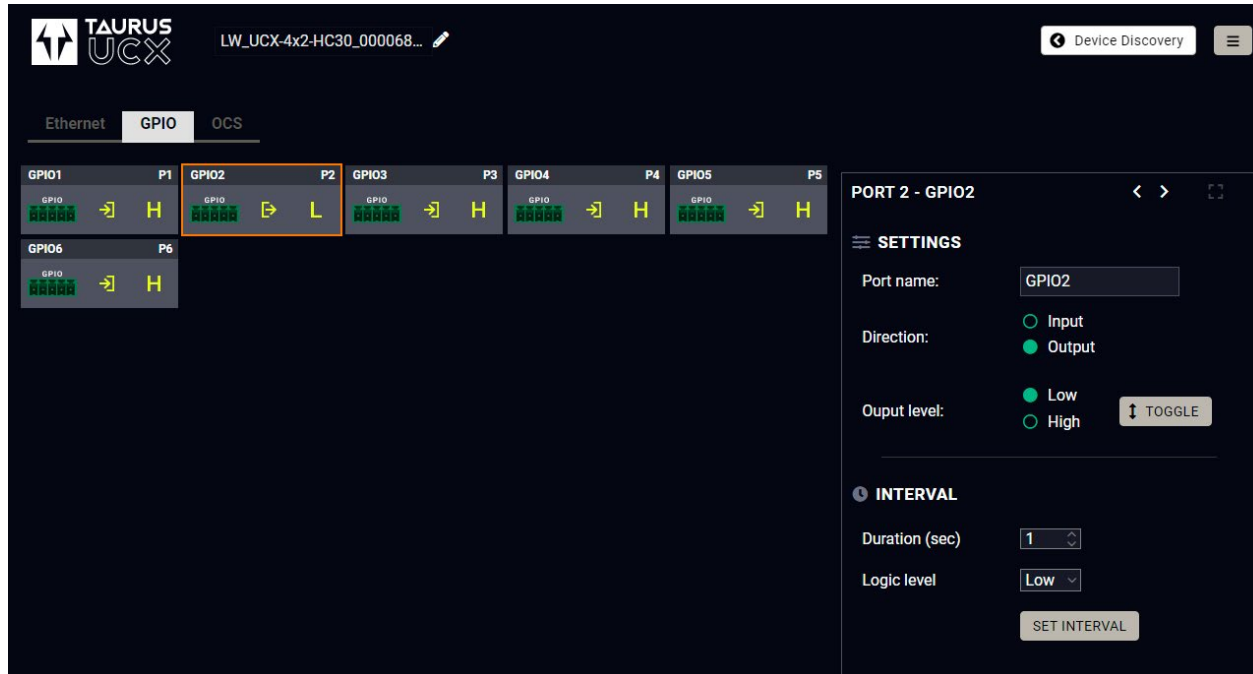

INFO: Output level can be set only in case of setting the pin direction to Output. In case of input direction the output level setting and the **Toggle** button is not available.

Interval

Interval section is designed for setting the chosen GPIO pin to the specified level for a specified time. Configure the **Duration** time and the **Logic level** of the desired value. Confirm by clicking the **Set interval** button.

6.10.2. OCS - Occupancy Sensor

DIFFERENCE: This feature is available only from FW package 1.1.0b7.

The OCS sensor has 3 pins, where first pin has a logic low and high level, the default state is low. The output voltage changes automatically 24V when an incoming signal is detected from the connected occupancy sensor.

Input level refers to the current input signal level of the first pin.

State value can be free or occupied, depending on the Sensor type setting and the Input level (e.g. when the sensor type is Active high and the input value is high, the state reports 'Occupied').

Sensor type can be active high/active low, and this defines that the low or high input level means the occupancy.

#ocs #new

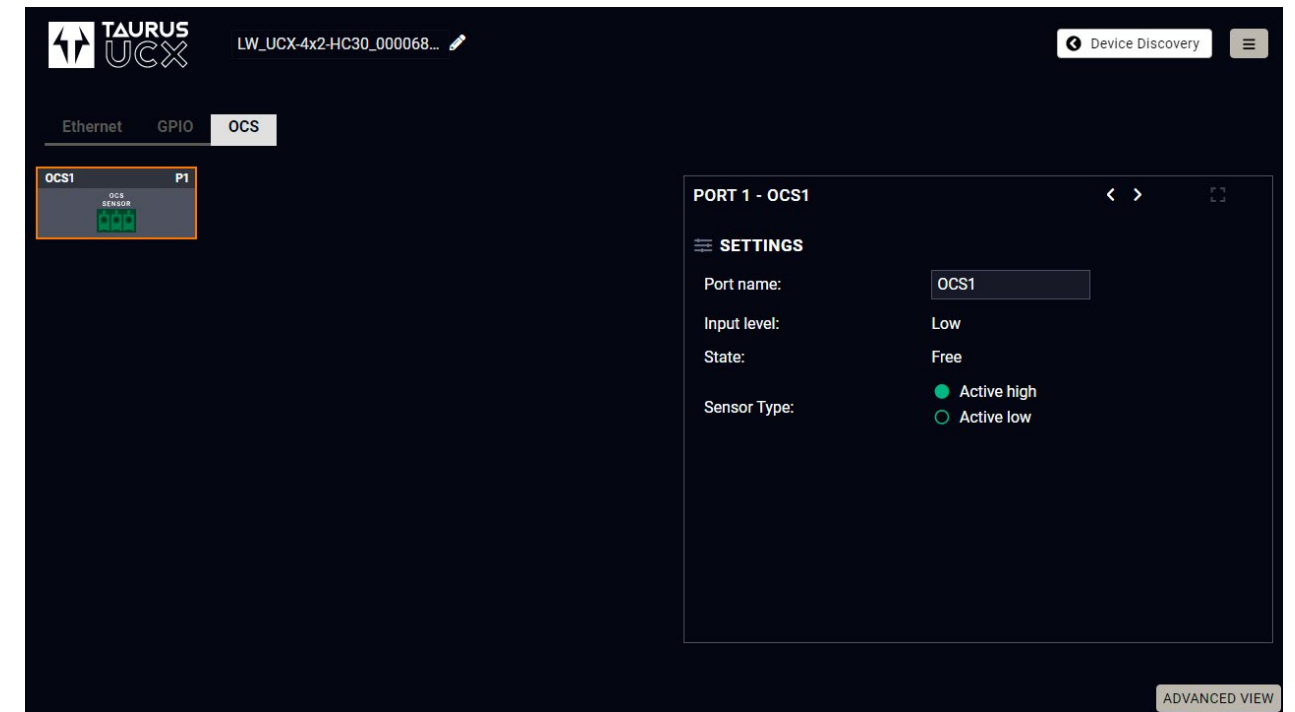

6.11. Settings Menu

6.11.1. Status

The screenshot displays the 'Status' tab within the 'SETTINGS' menu. The top navigation bar includes 'CROSSPOINTS', 'EDID MANAGEMENT', 'CONTROL', 'SETTINGS', and 'Device Discovery'. The 'Status' sub-tab is active, showing three sub-sections: 'GENERAL', 'MAC ADDRESSES', and 'OVERALL HEALTH STATUS'. The 'GENERAL' section lists product and hardware details. 'MAC ADDRESSES' shows the main and USB port addresses. 'OVERALL HEALTH STATUS' indicates that the health, temperature, and voltage states are all 'OK' (green checkmarks). Below this, 'VOLTAGES' and 'TEMPERATURES' provide specific numerical values and ranges for various system components.

Status tab in Settings menu

The most important hardware and software related information can be found on this tab: hardware and firmware version, serial numbers, MAC addresses, temperatures, and voltage information. Device label can be changed to unique description by the **Set** button. [#buttonlock](#) [#lockbutton](#)

You can disable the functionality of the front panel buttons with marking the **Lock front panel** option.

[#devicelabel](#) [#label](#) [#producttype](#) [#firmwareversion](#) [#status](#)

[#serialnumber](#)

6.11.2. Network

The screenshot displays the 'Network' sub-tab within the 'SETTINGS' menu. The top navigation bar is the same as in the Status tab. The 'Network' sub-tab is active, showing 'NETWORK SETTINGS'. It includes fields for 'Current IP address', 'Current subnet mask', and 'Current gateway address'. The 'Host name' field is set to 'lightware-00006864'. The 'Obtain IP address automatically (DHCP, AutoIP)' checkbox is checked. Below these are fields for 'Static IP address', 'Static subnet mask', and 'Static gateway address'. At the bottom, there are fields for 'LW3 port' and 'HTTP port'. 'APPLY CHANGES' and 'CANCEL' buttons are located at the bottom of the settings panel.

Network tab in Settings menu

IP address and DHCP settings can be set on this tab. Always press the **Apply settings** button to save changes.

[#network](#) [#ipaddress](#)

6.11.3. System

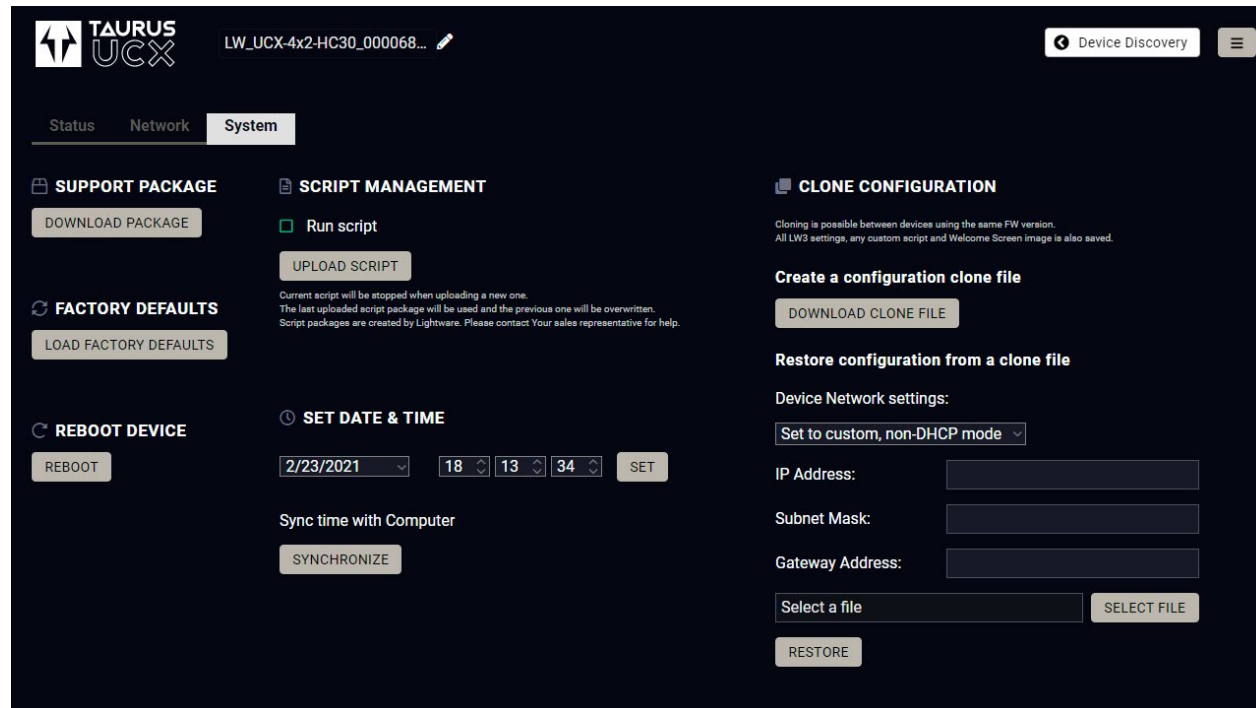

System tab in Settings menu

The following functions are available under System tab:

- **Support package** - saving a log file of the device, helps during the troubleshooting process
- **Load factory defaults** - recalling factory defaults settings and values. All factory default settings are listed in the [Factory Default Settings](#) section.
- **Reboot** - rebooting the system.
- **Set time** - (internal clock) of the switcher which is used for logging events.
- Pressing **Sync with Computer** button is a quick and easy way to set the time. *#factory #log #systemlog #reboot #restart*

Script management

DIFFERENCE: This feature is available only from FW package 1.0.1b1.

This interface is for running custom zipped file which is made by Lightware for special request.

Put a tick to enable the **Run script**. It means, that the script runs until the uploading another script or disable this function.

Click **Upload File** to browse a zipped file. It will replace the previous one.

Clone configuration *#new*

DIFFERENCE: This feature is available only from FW package 1.1.0b7.

Clone configuration makes possible saving all the LW3 settings, custom scripts and welcome screen image and upload to another device.

ATTENTION! Please note that clone configuration function operates properly when the same firmware version is installed on the devices.

Create a configuration clone file

Click on the [Download Clone File](#) button to save the setting to the computer.

Restore a configuration from a clone file

Step 1. Choose the desired network setting from the drop down menu: Keep unchanged / Restore from clone file / Set to DHCP mode / Set to custom non-DHCP mode (in this case additional settings required: IP Address, Subnet Mask, Gateway Address)

Step 2. Click on the **Select file** button to browse a clone file from the PC.

Step 3. The clone process will start by clicking on **Restore** button.

6.12. Advanced View Window

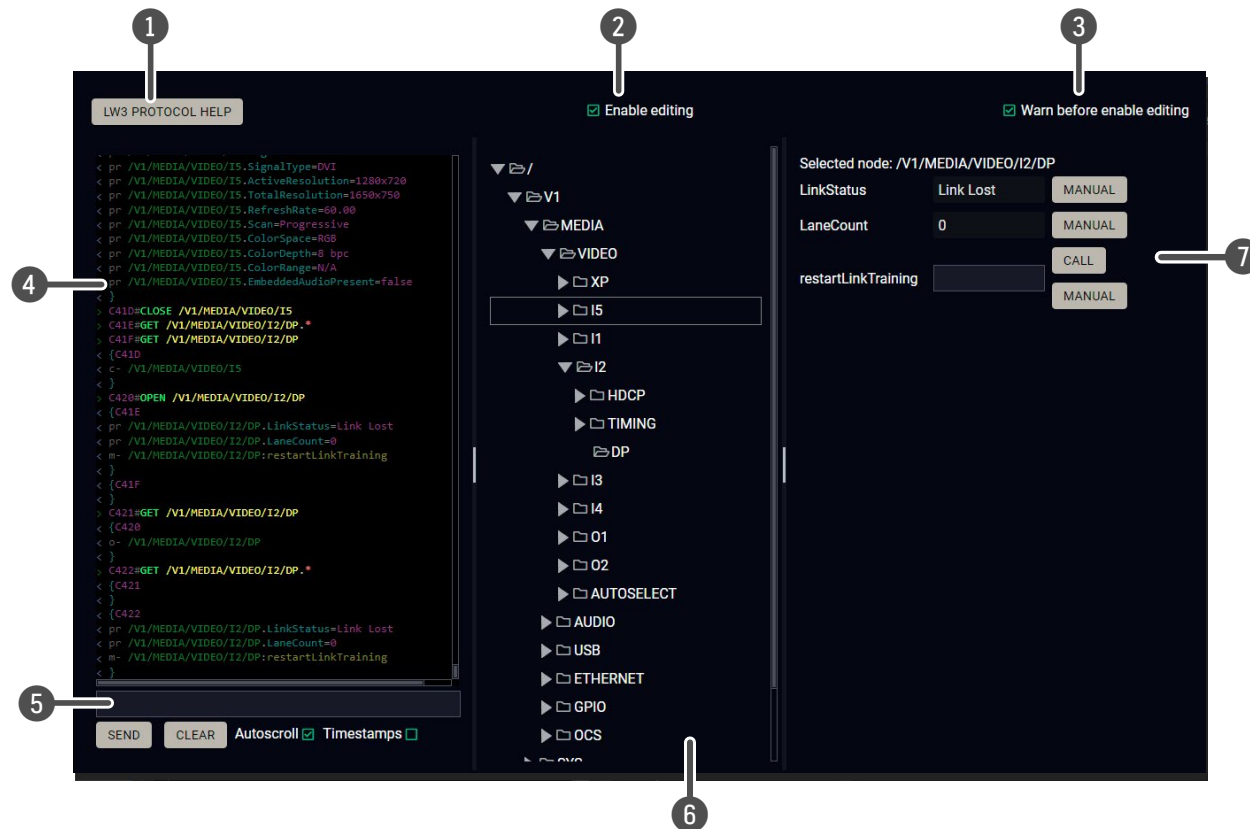

- 1 **LW3 protocol help** Pushing the button results a help window opening which describes the most important information about LW3 protocol commands in HTML format.
- 2 **Edit mode** The default appearance is the read-only mode. If you want to modify the values or parameters, tick the option. You will be prompted to confirm your selection.
- 3 **Warning mode** If this is checked, a warning window pops up when you enable Edit mode.
- 4 **Terminal window** Commands and responses with time and date are listed in this window. Sent command starts with '>' character, received response starts with '<' character. The color of each item depends on the type of the command and response. The content of the window can be emptied by the **Clear** button. If the **Autoscroll** option is ticked, the list is scrolled automatically when a new line is added.
- 5 **Command line** Type the desired command and execute it by the **Send** button. Clear all current commands and responses in the Terminal window by the **Clear** button.
- 6 **Protocol tree** LW3 protocol tree; select an item to see its content.
- 7 **Node list** Correspondent parameters and nodes are shown which are connected to the selected item in the protocol tree.
 - Manual button:** Manual (short description) of the node can be called and displayed in the terminal window.
 - Set button:** Saves the value/parameter typed in the textbox.
 - Call button:** Calls the method, e.g. reloads factory default settings.

#advancedview
#terminal

7

LW3 Programmers' Reference

The device can be controlled through Lightware 3 (LW3) protocol commands to ensure the compatibility with other Lightware products. The supported LW3 commands are described in this chapter.

- ▶ [OVERVIEW](#)
- ▶ [INSTRUCTIONS FOR THE TERMINAL APPLICATION USAGE](#)
- ▶ [PROTOCOL RULES](#)
- ▶ [SYSTEM COMMANDS](#)
- ▶ [VIDEO PORT SETTINGS - GENERAL](#)
- ▶ [WELCOME SCREEN SETTINGS](#)
- ▶ [VIDEO PORT SETTINGS - USB-C RELATED COMMANDS](#)
- ▶ [AUDIO PORT SETTINGS](#)
- ▶ [USB PORT SETTINGS](#)
- ▶ [USB PORT SETTINGS - USB-C RELATED COMMANDS](#)
- ▶ [EDID MANAGEMENT](#)
- ▶ [ETHERNET PORT CONFIGURATION](#)
- ▶ [GPIO PORT CONFIGURATION](#)
- ▶ [OCS PORT CONFIGURATION](#)
- ▶ [LW3 COMMANDS - QUICK SUMMARY](#)

7.1. Overview

The Lightware Protocol #3 (LW3) is implemented in almost all new Lightware devices (matrix switchers, signal extenders and distribution amplifiers) since 2012. The protocol is ASCII-based and all commands are terminated with a carriage return (Cr, '\r') and line feed (Lf, '\n') pair. It is organized as a tree structure that provides outstanding flexibility and user-friendly handling with 'nodes', 'properties' and 'methods'. The **Advanced View** of the Lightware Device Controller software is the perfect tool for browsing and learning how the LW3 protocol can be used in practice.

7.2. Instructions for the Terminal Application Usage

Terminal Application

The LW3 protocol commands can be applied to the switcher using a terminal application. You need to install one of them to your control device, for example **Putty** or **CLI**. `#terminal`

Establishing Connection

Follow the steps for establishing connection to the receiver:

- Step 1.** Connect the receiver to a LAN over Ethernet.
- Step 2.** Open the terminal application (e.g. Putty).
- Step 3.** Add the **IP address** of the device (default: DHCP) and the **port number (6107)**.
- Step 4.** Select the **Raw** connection type, and open the connection.

Once the terminal window is opened, you can enter the LW3 protocol commands which are listed in the following sections.

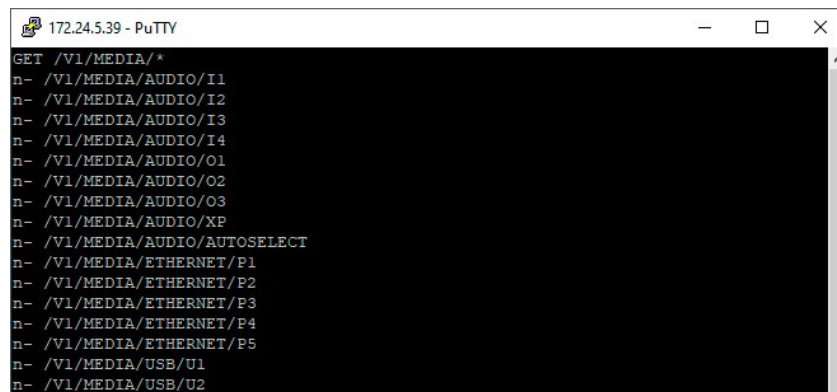
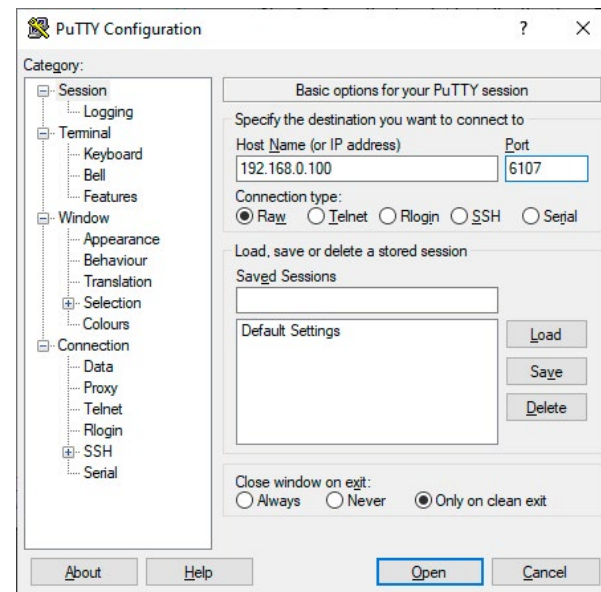

LW3 protocol command communication in a terminal window

7.3. Protocol Rules

7.3.1. LW3 Tree Structure and Command Structure (examples)

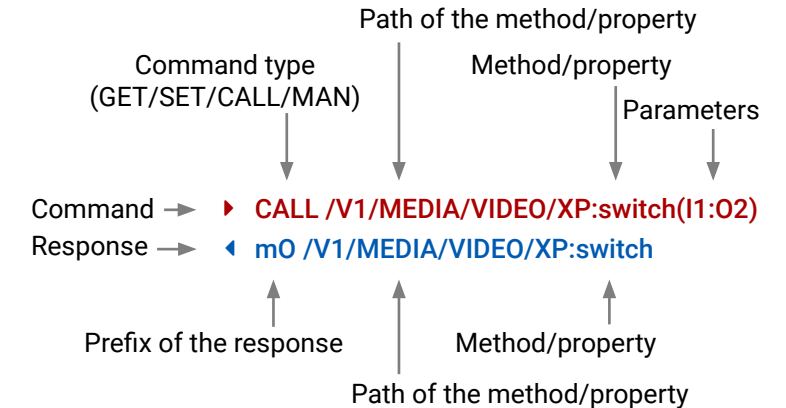
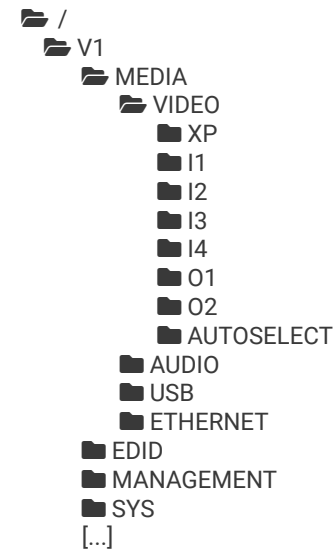

7.3.2. General Rules

- All names and parameters are **case-sensitive**.
- The nodes are separated by a slash ('/') character.
- The node name can contain the elements of the English alphabet and numbers.
- Use the **TCP port no. 6107** when using LW3 protocol over Ethernet.
- When a command is issued by the device, the received response cannot be processed by the CPU.
- The node paths describe the exact location of the node, listing each parent node up to the root.
- The length of a line (command/response, command type / prefix, path, method/property and parameters together) can be max. 800 byte.
- The command lines have to be closed by Carriage Return and Line Feed (CrLf)

7.3.3. Legend for the Control Commands

Command and Response – Example

- ▶ GET /V1/MEDIA/VIDEO/I2.SignalPresent
- ◀ pr /V1/MEDIA/VIDEO/I2.SignalPresent=<signal_present>

Format	Description
<in>	Input port number
<out>	Output port number
<port>	Input or output port number
<loc>	Location number
<parameter>	Variable defined and described in the command
<expression>	Batched parameters: the underline means that more expressions or parameters can be placed by using a semicolon, e.g. I2;I4;I5 or F27:E1;F47:E2
▶	Sent command
◀	Received response
.	Space character

Further not listed <parameters> are defined at each commands.

7.3.4. Command Types

GET command

The **GET** command can be used to get the child nodes, properties and methods of a specific node. It can also be used to get the value of a property. Use the dot character (.) when addressing a property:

- ▶ **GET /.SerialNumber**
- ◀ **pr /.SerialNumber=87654321**

GETALL command

The **GETALL** command can be used to get all child nodes, properties and methods of a node with one command.

- ▶ **GETALL /V1/MEDIA/ETHERNET**
- ◀ **n- /V1/MEDIA/ETHERNET/P1**
- ◀ **n- /V1/MEDIA/ETHERNET/P2**
- ◀ **n- /V1/MEDIA/ETHERNET/P3**
- ◀ **n- /V1/MEDIA/ETHERNET/P4**
- ◀ **n- /V1/MEDIA/ETHERNET/P5**

SET command

The **SET** command can be used to modify the value of a property. Use the dot character (.) when addressing the property:

- ▶ **SET /V1/MEDIA/VIDEO/I2/HDCP.AllowedHdcpVersion=Off**
- ◀ **pw /V1/MEDIA/VIDEO/I2/HDCP.AllowedHdcpVersion=Off**

CALL command

A method can be invoked by the **CALL** command. Use the colon character (:) when addressing the method:

- ▶ **CALL /V1/EDID:switchAll(F49)**
- ◀ **m0 /V1/EDID:switchAll**

MAN command

The manual is a human readable text that describes the syntax and provides a hint for how to use the primitives. For every node, property and method in the tree there is a manual, type the **MAN** command to get the manual:

- ▶ **MAN /V1/MEDIA/VIDEO/O1.Output5VMode**
- ◀ **pm /V1/MEDIA/VIDEO/O1.Output5VMode ["On" | "Auto" | "Off"] Enables/disables power 5V output**

7.3.5. Prefix Summary

DEFINITION: The prefix is a 2-character long code that describes the type of the response.

The following prefixes are defined in the LW3 protocol:

Prefix	Description	Prefix	Description
n-	a node	pm	a manual for the property
nE	an error for a node	m-	a method
nm	a manual for a node	mO	a response after a success method execution
pr	a read-only property	mF	a response after a failed method execution
pw	read-write property	mE	an error for a method
pE	an error for the property	mm	a manual for a method

7.3.6. Error Messages

There are several error messages defined in the LW3 protocol, all of them have a unique error number.

- ▶ `CALL /MEDIA/VIDEO/XP:lock(IA)`
- ◀ `mE /MEDIA/VIDEO/XP:lock %E002:Not exist`

7.3.7. Escaping

DEFINITION: An escape sequence is a sequence of characters that does not represent itself when used inside a character or string literal, but is translated into another character or a sequence of characters.

Property values and method parameters can contain characters which are used as control characters in the protocol. They must be escaped. The escape character is the backslash ('\') and escaping means injecting a backslash before the character that should be escaped (like in C language).

Control characters are the following: \ { } # % () \r \n \t

The **original** message: `CALL /V1/MEDIA/UART/P1:sendMessage(Set(01))`

The **escaped** message: `CALL /V1/MEDIA/UART/P1:sendMessage(Set\01\)`

7.3.8. Signature

DEFINITION: The signature is a four-digit-long hexadecimal value that can be optionally placed before every command to keep a command and the corresponding responses together as a group.

Each line is terminated with a Carriage Return (Cr, '\r') and Line Feed (Lf, '\n') characters. In several cases the number of the lines in the response cannot be determined in advance, e.g. the client intends to receive for the whole response and also wants to be sure, that the received lines belong together and to the same command. In these cases, a special feature the 'signature' can be used. The response to that particular command will also be preceded by the signature, and the corresponding lines will be between brackets:

- ▶ `1700#GET /V1/EDID.*`
- ◀ {1700
- ◀ `pr /V1/EDID.EdidStatus=F49:E1;F49:E2;F49:E3;F49:E4`
- ◀ `m- /V1/EDID:copy`
- ◀ `m- /V1/EDID:delete`
- ◀ `m- /V1/EDID:reset`
- ◀ `m- /V1/EDID:switch`
- ◀ `m- /V1/EDID:switchAll`
- ◀ }

INFO: The lines of the signature are also Cr and Lf terminated.

7.3.9. Subscription

DEFINITION: Subscription to a node means that the user will get a notification if a property of the node changes.

A user can subscribe to any node. These notifications are asynchronous messages and are useful to keep the client application up to date, without having to periodically poll the node to detect a changed property. When the user does not want to be informed about the changes anymore, he can simply unsubscribe from the node.

ATTENTION! The subscriptions are handled separately for connections. Hence, if the connection is terminated all registered subscriptions are deleted. After reopening a connection all subscribe commands have to be sent in order to get the notifications of the changes on that connection.

Subscribe to a Node

- ▶ `OPEN /V1/MEDIA/VIDEO`
- ◀ `o- /V1/MEDIA/VIDEO`

Get the Active Subscriptions

- ▶ `OPEN`
- ◀ `o- /V1/MANAGEMENT/LABEL`
- ◀ `o- /V1/MEDIA/VIDEO/XP/O1/SWITCHABLE`
- ◀ `o- /V1/MEDIA/VIDEO/XP/O2/SWITCHABLE`
- ◀ `o- /V1/MEDIA/VIDEO/XP/I5`

Subscribe to Multiple Nodes

- ▶ `OPEN /V1/MEDIA/VIDEO/*`
- ◀ `o- /V1/MEDIA/VIDEO/*`

Unsubscribe from a Node

- ▶ `CLOSE /V1/MEDIA/VIDEO`
- ◀ `c- /V1/MEDIA/VIDEO`

Unsubscribe from Multiple Nodes

- ▶ `CLOSE /V1/MEDIA/VIDEO/*`
- ◀ `c- /V1/MEDIA/VIDEO/*`

7.3.10. Notifications about the Changes of the Properties

When the value of a property is changed and the user is subscribed to the node, which the property belongs to, an asynchronous notification is generated. This notification is called as the 'change message'. The format of such a message is very similar to the response for the **GET** command:

◀ CHG /EDID.EdidStatus=F48:E1

A Short Example of How to Use the Subscription

There are two independent users controlling the device through two independent connections (**Connection #1** and **Connection #2**). The events in the rows occur after each other.

▶ OPEN /V1/MEDIA/AUDIO/O3	}	Connection #1
◀ o- /V1/MEDIA/AUDIO/O3		
▶ GET /V1/MEDIA/AUDIO/O3.VolumePercent		
◀ pw /V1/MEDIA/AUDIO/O3.VolumePercent=100.00	}	Connection #2
▶ GET /V1/MEDIA/AUDIO/O3.VolumePercent		
◀ pw /V1/MEDIA/AUDIO/O3.VolumePercent=100.00		
▶ SET /V1/MEDIA/AUDIO/O3.VolumePercent=50.00	}	Connection #1
◀ pw /V1/MEDIA/AUDIO/O3.VolumePercent=50.00		
◀ CHG /V1/MEDIA/AUDIO/O3.VolumePercent=50.00		

The first user (**Connection #1**) set a subscription to a node. Later the other user (**Connection #2**) made a change, and thanks for the subscription, the first user got a notification about the change.

7.4. System Commands

7.4.1. Set the Device Label

INFO: The device label can be changed to a custom text in the [Status](#) tab of the LDC software.

Command and Response *#devicelabel #label*

- ▶ SET /V1/MANAGEMENT/LABEL.DeviceLabel=<custom_name>
- ◀ pw /V1/MANAGEMENT/LABEL.DeviceLabel=<custom_name>

The Device Label can be 49 character length and ASCII characters are allowed. Longer names are truncated.

Example

- ▶ SET /V1/MANAGEMENT/LABEL.DeviceLabel=UCX_Conference_room1
- ◀ pw /V1/MANAGEMENT/LABEL.DeviceLabel=UCX_Conference_room1

7.4.2. Reset the Device

The switcher can be restarted – the current connections will be terminated.

Command and Response *#reboot #restart*

- ▶ CALL /V1/SYS:restart()
- ◀ mO /V1/SYS:restart=

Example

- ▶ CALL /V1/SYS:restart()
- ◀ mO /V1/SYS:restart=

7.4.3. Restore the Factory Default Settings

Command and Response

- ▶ CALL /V1/SYS:factoryDefaults()
- ◀ mO /V1/SYS:factoryDefaults=

Example

- ▶ CALL /V1/SYS:factoryDefaults()
- ◀ mO /V1/SYS:factoryDefaults=

The device is restarted, current connections are terminated, and the default settings are restored. See the complete list in the [Factory Default Settings](#) section.

#factory

7.4.4. Querying the Firmware Package Version

Command and Response *#firmwareversion*

- ▶ GET /V1/MANAGEMENT/UID/PACKAGE.Version
- ◀ pr /V1/MANAGEMENT/UID/PACKAGE.Version=<firmware_version>

Example

- ▶ GET V1/MANAGEMENT/UID/PACKAGE.Version
- ◀ pr /V1/MANAGEMENT/UID/PACKAGE.Version=1.0.0b2

7.4.5. Control Lock

Enable/disable the operation of the front panel buttons.

Command and Response *#lockbutton #buttonlock*

- ▶ SET /V1/MANAGEMENT/UI.ControlLock=<lock_status>
- ◀ pw /V1/MANAGEMENT/UI.ControlLock=<lock_status>

Parameters

Parameter	Parameter description	Values	Value description
<lock_status>	Front panel button locking status	None force locked	None: all functions of the front panel button are enabled. The front panel buttons are locked and cannot be unlocked by button combination, only in LDC (on the Status tab) or using the LW3 command.

Example

- ▶ SET /V1/MANAGEMENT/UI.ControlLock=force locked
- ◀ pw /V1/MANAGEMENT/UI.ControlLock=force locked

7.4.6. Set Current Time

Command and Response *#time*

- ▶ CALL /V1/MANAGEMENT/DATETIME:setTime(<current_time>)
- ◀ mO /V1/MANAGEMENT/DATETIME:setTime=

Parameters

<current_time>: The new router time in ISO 8601 date time format.

Example

- ▶ CALL /V1/MANAGEMENT/DATETIME:setTime(2020-11-01T04:39:54.000Z)
- ◀ mO /V1/MANAGEMENT/DATETIME:setTime=

7.5. Video Port Settings - General

7.5.1. Switch Video Input

Command and Response

- ▶ CALL /V1/MEDIA/VIDEO/XP:switch(<in>:<out>)
- ◀ mO /V1/MEDIA/VIDEO/XP:switch=

Example

- ▶ CALL /V1/MEDIA/VIDEO/XP:switch(I5:O1)
- ◀ mO /V1/MEDIA/VIDEO/XP:switch=

INFO: When using the '0' value as an input, the input will be disconnected and no signal will appear on the output.

ATTENTION! Video crosspoint has a limitation: I1 and I5 ports are not available at the same time, only one of them can be selected to any output. When one of the outputs is switched to I1 or I5 the other output can not be switched to I1 or I5. In this case the switch command returns error message.

Example

- ▶ GET /V1/MEDIA/VIDEO/XP/O1.ConnectedSource
- ◀ pw /V1/MEDIA/VIDEO/XP/O1.ConnectedSource=I5
- ▶ GET /V1/MEDIA/VIDEO/XP/O2.ConnectedSource
- ◀ pw /V1/MEDIA/VIDEO/XP/O2.ConnectedSource=I5
- ▶ CALL /V1/MEDIA/VIDEO/XP:switch(I1:O1)
- ◀ mE /V1/MEDIA/VIDEO/XP:switch %E006: Illegal operation

7.5.2. Switch an Input to All Outputs

Command and Response

- ▶ CALL /V1/MEDIA/VIDEO/XP:switchAll(<input>)
- ◀ mO /V1/MEDIA/VIDEO/XP:switchAll=

Example

- ▶ CALL /V1/MEDIA/VIDEO/XP:switchAll(I1)
- ◀ mO /V1/MEDIA/VIDEO/XP:switchAll=

7.5.3. Lock the Video Port

Command and Response

- ▶ SET /V1/MEDIA/VIDEO/XP/<port>.Lock=<locked_state>
- ◀ pw /V1/MEDIA/VIDEO/XP/<port>.Lock=<locked_state>

Parameters

Parameter	Parameter description	Values	Value description
<locked_state>	Locked state	true	The port is locked
		false	The port is unlocked

Example

- ▶ SET /V1/MEDIA/VIDEO/XP/I2.Lock=false
- ◀ pw /V1/MEDIA/VIDEO/XP/I2.Lock=false

7.5.4. Mute the Video Port

Command and Response

- ▶ SET /V1/MEDIA/VIDEO/XP/<port>.Mute=<muted_state>
- ◀ pw /V1/MEDIA/VIDEO/XP/<port>.Mute=<muted_state>

Parameters

Parameter	Parameter description	Values	Value description
<muted_state>	Muted state	true	The port is locked.
		false	The port is unlocked.

Example

- ▶ SET /V1/MEDIA/VIDEO/XP/I2.Mute=false
- ◀ pw /V1/MEDIA/VIDEO/XP/I2.Mute=false

7.5.5. Set the Autoselect Policy

Command and Response

- ▶ SET /V1/MEDIA/VIDEO/AUTOSELECT/<out>.Policy=<autoselect_mode>
- ◀ pw /V1/MEDIA/VIDEO/AUTOSELECT/<out>.Policy=<autoselect_mode>

Parameters

Parameter	Parameter description	Values	Value description
<autoselect_mode>	The autoselect policy	Off	The autoselect function is disabled.
		Last Detect	Always the last attached input is switched to the output automatically.
		First Detect	The first active video input is selected.

Example

- ▶ SET /V1/MEDIA/VIDEO/AUTOSELECT/O2.Policy=First detect
- ◀ pw /V1/MEDIA/VIDEO/AUTOSELECT/O2.Policy=First detect

7.5.6. Change the Autoselect Included Input Ports

Command and Response

- ▶ SET /V1/MEDIA/VIDEO/AUTOSELECT/<out>/<in>.Included=<state>
- ◀ pw /V1/MEDIA/VIDEO/AUTOSELECT/<out>/<in>.Included=<state>

Parameters

Parameter	Parameter description	Values	Value description
<state>	The chosen input is ignored from the autoselect process or not.	true	The port is included in autoselect.
		false	The autoselect function ignores that port.

Example

- ▶ SET /V1/MEDIA/VIDEO/AUTOSELECT/O2/I1.Included=false
- ◀ pw /V1/MEDIA/VIDEO/AUTOSELECT/O2/I1.Included=false

7.5.7. Change the Input Port Priority

Command and Response

- ▶ SET /V1/MEDIA/VIDEO/AUTOSELECT/<out>/<in>.Priority=<prio_num>
- ◀ pw /V1/MEDIA/VIDEO/AUTOSELECT/<out>/<in>.Priority=<prio_num>

Parameters

The <prio> parameters means the priority number from 1 to 100, equal numbers are allowed. Inputs can have different priorities in relation with two or more outputs. Therefore the output port number is part of the node path of input port priorities.

Example

- ▶ SET /V1/MEDIA/VIDEO/AUTOSELECT/O2/I2.Priority=51
- ◀ pw /V1/MEDIA/VIDEO/AUTOSELECT/O2/I2.Priority=51

7.5.8. Query the Connected Source

Command and Response

- ▶ GET /V1/MEDIA/VIDEO/XP/<out>.ConnectedSource
- ◀ pw /V1/MEDIA/VIDEO/XP/<out>.ConnectedSource=<in>

Example

- ▶ GET /V1/MEDIA/VIDEO/XP/O3.ConnectedSource
- ◀ pw /V1/MEDIA/VIDEO/XP/O3.ConnectedSource=I2

7.5.9. Query the Connected Destinations

Command and Response

- ▶ GET /V1/MEDIA/VIDEO/XP/<n>.ConnectedDestinations
- ◀ pr /V1/MEDIA/AUDIO/XP/<in>.ConnectedDestinations=<out>

Example

- ▶ GET /V1/MEDIA/VIDEO/XP/I3.ConnectedDestinations
- ◀ pr /V1/MEDIA/VIDEO/XP/I3.ConnectedDestinations=01;02

7.5.10. Query the Input Switchable Ability

Video crosspoint has a limitation: I1 or I5 ports can not be selected to any output at the same time. **Busy** value of the switchable property refers to the limitation.

Command and Response

- ▶ GET /V1/MEDIA/VIDEO/XP/<out>/SWITCHABLE.<in>
- ◀ pr /V1/MEDIA/VIDEO/XP/<out>/SWITCHABLE.<in>=<switchable_state>

Parameters

Parameter	Parameter description	Values	Value description
<switchable_state>	The chosen input is can be switched to the output or not.	OK	The connection of the chosen input and output is allowed.
		Busy	The chosen input can not be switched to the output.

Example

- ▶ GET /V1/MEDIA/VIDEO/XP/O2/SWITCHABLE.I1
- ◀ pr /V1/MEDIA/VIDEO/XP/O2/SWITCHABLE.I1=Busy

7.5.11. SignalPresent

Command and Response

- ▶ GET /V1/MEDIA/VIDEO/<port>.SignalPresent
- ◀ pr /V1/MEDIA/VIDEO/<port>.SignalPresent=<state>

Parameters

Parameter	Parameter description	Values	Value description
<state>	This property gives a feedback about the current signal presence of the port.	true	The video signal is present.
		false	The video signal is not present.

Example

- ▶ GET /V1/MEDIA/VIDEO/I1.SignalPresent
- ◀ pr /V1/MEDIA/VIDEO/I1.SignalPresent=false

7.5.12. HDCP Setting (Input Port)

HDCP capability can be set on the input ports, thus, non-encrypted content can be seen on a non-HDCP compliant display. See more information in the [HDCP Management](#) section.

ATTENTION! HDCP 2.2 signal handing is limited up to two input ports at the same time.

Command and Response #hdcp

- ▶ SET /V1/MEDIA/VIDEO/<in>/HDCP.AllowedHdcpVersion=<allowed_hdcp>
- ◀ pw /V1/MEDIA/VIDEO/<in>/HDCP.AllowedHdcpVersion=<allowed_hdcp>

Parameters

Parameter	Parameter description	Values	Value description
<allowed_hdcp>	The input port reports this HDCP capability.	HDCP 1.4	The input port reports HDCP 1.4 capability.
		HDCP 2.2	The input port reports HDCP 2.2 capability.
		Off	The input port reports non-HDCP compliant.

Example

- ▶ SET /V1/MEDIA/VIDEO/I1/HDCP.AllowedHdcpVersion=HDCP 1.4
- ◀ pw /V1/MEDIA/VIDEO/I1/HDCP.AllowedHdcpVersion=HDCP 1.4

7.5.13. HdcpMode

HDCP capability can be set to Auto/Always on the output ports, thus, non-encrypted content can be transmitted to a non-HDCP compliant display. See more information in the [HDCP Management](#) section.

Command and Response #hdcp

- ▶ SET /V1/MEDIA/VIDEO/<out>.HdcpMode=<hdcp_mode>
- ◀ pw /V1/MEDIA/VIDEO/<out>.HdcpMode=<hdcp_mode>

Parameters

Parameter	Parameter description	Values	Value description
<hdcp_mode>	HDCP encryption setting on the output port	Auto	The encryption is enabled on the output port if the signal on the input port is encrypted.
		Always	The outgoing signal is HDCP-encrypted.

Example

- ▶ SET /V1/MEDIA/VIDEO/O1/HDCP.HdcpMode=Auto
- ◀ pw /V1/MEDIA/VIDEO/O1/HDCP.HdcpMode=Auto

7.5.14. EmbeddedAudioPresent

- ▶ GET /V1/MEDIA/VIDEO/<port>.EmbeddedAudioPresent
- ◀ pr /V1/MEDIA/VIDEO/<port>.EmbeddedAudioPresent=<embedded_state>

Parameters

Parameter	Parameter description	Values	Value description
<embedded_state>	It shows if the video contains audio or not.	true	There is embedded audio in the video signal.
		false	There is no embedded audio in the video signal.

Example

- ▶ GET /V1/MEDIA/VIDEO/I2.EmbeddedAudioPresent
- ◀ pr /V1/MEDIA/VIDEO/I2.EmbeddedAudioPresent=false

7.5.15. EmbeddedAudioMute

- ▶ SET /V1/MEDIA/VIDEO/<port>.EmbeddedAudioMute=<mute_state>
- ◀ pw /V1/MEDIA/VIDEO/<port>.EmbeddedAudioMute=<mute_state>

Parameters

Parameter	Parameter description	Values	Value description
<mute_state>	It shows if the embedded audio is muted or not.	true	The embedded audio is muted.
		false	The embedded audio is unmuted.

Example

- ▶ SET /V1/MEDIA/VIDEO/O1.EmbeddedAudioMute=false
- ◀ pw /V1/MEDIA/VIDEO/O1.EmbeddedAudioMute=false

7.5.16. OutputSignalType

Command and Response #signaltype

- ▶ SET /V1/MEDIA/VIDEO/<out>.OutputSignalType=<signal_type>
- ◀ pw /V1/MEDIA/VIDEO/<out>.OutputSignalType=<signal_type>

Parameters

Parameter	Parameter description	Values	Value description
<signal_type>	Signal type setting	Auto	The outgoing signal type is HDMI.
		DVI	The outgoing signal type is DVI.

Example

- ▶ SET /V1/MEDIA/VIDEO/O1.OutputSignalType=Auto
- ◀ pw /V1/MEDIA/VIDEO/O1.OutputSignalType=Auto

7.5.17. Output5VMode

The 5V power towards the sink can be enabled or disabled as follows:

Command and Response

- ▶ SET /V1/MEDIA/VIDEO/<out>.Output5VMode=<5V_pwr>
- ◀ pw /V1/MEDIA/VIDEO/<out>.Output5VMode=<5V_pwr>

Parameters

Parameter	Parameter description	Value	Value description
<5V_pwr>	5V power towards the sink	On	Enable 5V power on HDMI port
		Off	Disable 5V power on HDMI port

Example

- ▶ SET /V1/MEDIA/VIDEO/O1.Output5VMode=On
- ◀ pw /V1/MEDIA/VIDEO/O1.Output5VMode=On

7.6. Welcome Screen Settings

7.6.1. Display Welcome Screen Image

Command and Response *#welcomescreen*

- ▶ SET /V1/MEDIA/VIDEO/I5/WELCOMESCREEN.ImageEnabled=<image_state>
- ◀ pw /V1/MEDIA/VIDEO/I5/WELCOMESCREEN.ImageEnabled=<image_state>

Parameters

Parameter	Parameter description	Values	Value description
<image_state>		true false	The welcome screen image is displayed. The welcome screen image is not displayed.

Example

- ▶ SET /V1/MEDIA/VIDEO/I5/WELCOMESCREEN.ImageEnabled=true
- ◀ pw /V1/MEDIA/VIDEO/I5/WELCOMESCREEN.ImageEnabled=true

7.6.2. Display Welcome Screen Text

Command and Response

- ▶ SET /V1/MEDIA/VIDEO/I5/WELCOMESCREEN.MessageEnabled=<text_state>
- ◀ pw /V1/MEDIA/VIDEO/I5/WELCOMESCREEN.MessageEnabled=<text_state>

Parameters

Parameter	Parameter description	Values	Value description
<text_state>		true false	The welcome screen text is displayed. The welcome screen text is not displayed.

Example

- ▶ SET /V1/MEDIA/VIDEO/I5/WELCOMESCREEN.MessageEnabled=false
- ◀ pw /V1/MEDIA/VIDEO/I5/WELCOMESCREEN.MessageEnabled=false

7.6.3. Set Welcome Screen Text

Command and Response

- ▶ SET /V1/MEDIA/VIDEO/I5/WELCOMESCREEN.MessageText=<text>
- ◀ pw /V1/MEDIA/VIDEO/I5/WELCOMESCREEN.MessageText=<text>

Parameters

The <text> may consist of letters (A-Z) and (a-z), hyphen (-), underscore (_), numbers (0-9), space () and dot (.). Max length: 63 character. Longer names are truncated.

Example

- ▶ SET /V1/MEDIA/VIDEO/I5/WELCOMESCREEN.MessageText=info
- ◀ pw /V1/MEDIA/VIDEO/I5/WELCOMESCREEN.MessageText=info

7.6.4. Reset Welcome Screen Image

This command restores the original welcome screen image.

Command and Response

- ▶ CALL /V1/MEDIA/VIDEO/I5/WELCOMESCREEN:resetImage()
- ◀ m0 /V1/MEDIA/VIDEO/I5/WELCOMESCREEN:resetImage=

Example

- ▶ CALL /V1/MEDIA/VIDEO/I5/WELCOMESCREEN:resetImage()
- ◀ m0 /V1/MEDIA/VIDEO/I5/WELCOMESCREEN:resetImage=

7.7. Video Port Settings - USB-C Related Commands

7.7.1. Restart Link Training

This method is equal with pulling out and plug in again the USB-C connector.

Command and Response *#linktraining*

- ▶ CALL /V1/MEDIA/VIDEO/<in>/DP:restartLinkTraining()
- ◀ m0 /V1/MEDIA/VIDEO/<in>/DP:restartLinkTraining=

Example

- ▶ CALL /V1/MEDIA/VIDEO/I1/DP:restartLinkTraining()
- ◀ m0 /V1/MEDIA/VIDEO/I1/DP:restartLinkTraining=

7.8. Audio Port Settings

7.8.1. Switch Audio Input

Command and Response

- ▶ CALL /V1/MEDIA/AUDIO/XP:switch(<audio_in>:03)
- ◀ m0 /V1/MEDIA/AUDIO/XP:switch=

Parameters

Parameter	Parameter description	Values	Value description
<audio_in>	Audio input port	I1-I4	Audio input port number

Example

- ▶ CALL /V1/MEDIA/AUDIO/XP:switch(I2:03)
- ◀ m0 /V1/MEDIA/AUDIO/XP:switch=

INFO: When using the '0' value as an input, the input will be disconnected and no signal will appear on the output.

ATTENTION! When I5 is selected for video source, the de-embedded audio of the I1 is not available because the video crosspoint has a limitation: I1 and I5 ports are not available at the same time, only one of them can be selected to any output. For more details about it see the port diagram in [Audio Interface](#) section.

7.8.2. Query the Connected Source

Command and Response

- ▶ GET /V1/MEDIA/AUDIO/XP/O3.ConnectedSource
- ◀ pw /V1/MEDIA/AUDIO/XP/O3.ConnectedSource=<audio_in>

Parameters

Parameter	Parameter description	Values	Value description
<audio_in>	Audio input port	I1-I4	Audio input port number

Example

- ▶ GET /V1/MEDIA/AUDIO/XP/O3.ConnectedSource
- ◀ pw /V1/MEDIA/AUDIO/XP/O3.ConnectedSource=I2

7.8.3. Query the Connected Destinations

Command and Response

- ▶ GET /V1/MEDIA/AUDIO/XP/<audio_in>.ConnectedDestinations
- ◀ pr /V1/MEDIA/AUDIO/XP/<audio_in>.ConnectedDestinations=

Parameters

Parameter	Parameter description	Values	Value description
<audio_in>	Audio input port	I1-I4	Audio input port number

Example

- ▶ GET /V1/MEDIA/AUDIO/XP/I3.ConnectedDestinations
- ◀ pr /V1/MEDIA/AUDIO/XP/I3.ConnectedDestinations=

7.8.4. Set Autoselect Operation Mode

Command and Response

- ▶ SET /V1/MEDIA/AUDIO/AUTOSELECT/O3.Policy=<op_mode>
- ◀ pw /V1/MEDIA/AUDIO/AUTOSELECT/O3.Policy=<op_mode>

Parameters

Parameter	Parameter description	Values	Value description
<op_mode>	Operation mode	Follow video Off	Follows the video crosspoint state automatically. Autoselect function is disabled.

Example

- ▶ SET /V1/MEDIA/AUDIO/AUTOSELECT/O3.Policy=Follow video
- ◀ pw /V1/MEDIA/AUDIO/AUTOSELECT/O3.Policy=Follow video

7.8.5. Set the Followed Video Port to Autoselect

Command and Response

- ▶ SET /V1/MEDIA/AUDIO/AUTOSELECT/O3.VideoFollowPort=<out>
- ▶ pw /V1/MEDIA/AUDIO/AUTOSELECT/O3.VideoFollowPort=<out>

Example

- ▶ SET /V1/MEDIA/AUDIO/AUTOSELECT/O3.VideoFollowPort=O1
- ◀ pw /V1/MEDIA/AUDIO/AUTOSELECT/O3.VideoFollowPort=O1

7.8.6. Lock the Audio Port

Command and Response

- ▶ SET /V1/MEDIA/AUDIO/XP/<audio_port>.Lock=<locked_state>
- ◀ pw /V1/MEDIA/AUDIO/XP/<audio_port>.Lock=<locked_state>

Parameters

Parameter	Parameter description	Values	Value description
<audio_port>	Audio Port	I1-I4 O3	Audio input port number Audio output port number
<locked_state>	Locked state	true false	The port is locked The port is unlocked

Example

- ▶ SET /V1/MEDIA/AUDIO/XP/I2.Lock=false
- ◀ pw /V1/MEDIA/AUDIO/XP/I2.Lock=false

7.8.7. Mute the Audio Port 1.

■ INFO: Suspends the connection of the chosen port (no signal is forwarded).

Command and Response

- ▶ SET /V1/MEDIA/AUDIO/XP/<audio_port>.Mute=<muted_state>
- ◀ pw /V1/MEDIA/AUDIO/XP/<audio_port>.Mute=<muted_state>

Parameters

Parameter	Parameter description	Values	Value description
<audio_port>	Audio Port	I1-I4 O3	Audio input port number Audio output port number
<muted_state>	Muted state	true false	The port is muted. The port is unmuted.

Example

- ▶ SET /V1/MEDIA/AUDIO/XP/I2.Mute=false
- ◀ pw /V1/MEDIA/AUDIO/XP/I2.Mute=false

INFO: All inputs and analog output ports have a mute property in the audio XP (e.g. /V1/MEDIA/AUDIO/XP/I1.Mute). Outputs have a separate mute function within the port node as well:

- /V1/MEDIA/VIDEO/XP/O1.EmbeddedAudioMute
- /V1/MEDIA/VIDEO/XP/O2.EmbeddedAudioMute
- /V1/MEDIA/AUDIO/O3.Mute

7.8.8. Mute the Audio Port 2.

INFO: The volume of the analog audio output is set to low.

Command and Response

- ▶ SET /V1/MEDIA/AUDIO/O3.Mute=<muted_state>
- ◀ pw /V1/MEDIA/AUDIO/O3.Mute=<muted_state>

Parameters

Parameter	Parameter description	Values	Value description
<audio_port>	Audio Port	I1-I4 O3	Audio input port number Audio output port number
<muted_state>	Muted state	true false	The port is muted. The port is unmuted.

Example

- ▶ SET /V1/MEDIA/AUDIO/O3.Mute=true
- ◀ pw /V1/MEDIA/AUDIO/O3.Mute=true

7.8.9. Query the Audio Signal Presence

Command and Response

- ▶ GET /V1/MEDIA/AUDIO/<audio_port>.SignalPresent
- ◀ pr /V1/MEDIA/AUDIO/<audio_port>.SignalPresent=<signal_state>

Parameters

Parameter	Parameter description	Values	Value description
<audio_port>	USB Port	I1-I4 O3	Audio input port number Audio output port number
<signal_state>	Signal presence	true false	The audio signal is present. No audio signal is present.

Example

- ▶ GET /V1/MEDIA/AUDIO/I1.SignalPresent
- ◀ pr /V1/MEDIA/AUDIO/I1.SignalPresent=false

7.8.10. Analog Audio Output Volume (dB) Setting

Command and Response #analogaudio #volume

- ▶ SET /V1/MEDIA/AUDIO/O3.VoluedB=<level>
- ◀ pw /V1/MEDIA/AUDIO/O3.VoluedB=<level>

Parameter

The <level> parameters sets the output volume (attenuation) between -95.62 dB and 0 dB in step of -0.375 dB. The value is rounded up if necessary to match with the step value.

Example

- ▶ SET /V1/MEDIA/AUDIO/O3.VoluedB=-15
- ◀ pw /V1/MEDIA/AUDIO/O3.VoluedB=-15.00

7.8.11. Analog Audio Output Volume Percent Setting

Command and Response

- ▶ SET /V1/MEDIA/AUDIO/O3.VolumePercent=<percent>
- ◀ pw /V1/MEDIA/AUDIO/O3.VolumePercent=<percent>

Parameters

The <percent> parameter sets the output volume (attenuation) between 100% and 0%, in step of 1%. The value is rounded up if necessary to match with the step value.

Example

- ▶ SET /V1/MEDIA/AUDIO/O3.VolumePercent=50
- ◀ pw /V1/MEDIA/AUDIO/O3.VolumePercent=50.00

7.8.12. Setting the Balance

Command and Response #balance

- ▶ SET /V1/MEDIA/AUDIO/O3.Balance=<level>
- ◀ pw /V1/MEDIA/AUDIO/O3.Balance=<level>

Parameters

The <level> parameter sets the balance; -100 means left balance, 100 means right balance, step is 1. Center is 0 (default).

Example

- ▶ SET /V1/MEDIA/AUDIO/O3.Balance=0
- ◀ pw /V1/MEDIA/AUDIO/O3.Balance=0

7.8.13. Analog Audio Output Level Settings by Steps (dB)

Command and Response *#analogaudio #volume*

- ▶ CALL /V1/MEDIA/AUDIO/O3:stepVolumedB(<step>)
- ◀ m0 /V1/MEDIA/AUDIO/O3:stepVolumedB=

Parameters

The volume is increased or decreased with the given <step> value in dB.

Example

- ▶ CALL /V1/MEDIA/AUDIO/O3:stepVolumedB(-1)
- ◀ m0 /V1/MEDIA/AUDIO/O3:stepVolumedB=

The volume is decreased with 1 dB, the current volume is -1.95 dB which means 77.84% in percent.

7.8.14. Analog Audio Output Level Settings by Steps in Percent

Command and Response

- ▶ CALL /V1/MEDIA/AUDIO/O3:stepVolumePercent(<step>)
- ◀ m0 /V1/MEDIA/AUDIO/O3:stepVolumePercent=

Parameters

The volume is increased or decreased by the given <step> value in percent.

Example

- ▶ CALL /V1/MEDIA/AUDIO/O3:stepVolumePercent(5)
- ◀ m0 /V1/MEDIA/AUDIO/O3:stepVolumePercent=

The volume is increased with 5%, the current volume is -1.52 dB which means 82.84% in percent.

7.8.15. Analog Audio Output Balance by Steps

Command and Response

- ▶ CALL /V1/MEDIA/AUDIO/O3:stepBalance(<step>)
- ◀ m0 /V1/MEDIA/AUDIO/O3:stepBalance=

Parameters

The volume is increased or decreased by the given <step> value.

Example

- ▶ CALL /V1/MEDIA/AUDIO/O3:stepBalance(-5)
- ◀ m0 /V1/MEDIA/AUDIO/O3:stepBalance=

7.9. USB Port Settings

7.9.1. Switch USB Input

Command and Response *#usb*

- ▶ CALL /V1/MEDIA/USB/XP:switch(<host>:H1)
- ◀ m0 /V1/MEDIA/USB/XP:switch=

Parameters

Parameter	Parameter description	Values	Value description
<host>	USB Host	U1-U4	USB-C and USB-B port number

Example

- ▶ CALL /V1/MEDIA/USB/XP:switch(U1:H1)
- ◀ m0 /V1/MEDIA/USB/XP:switch=

INFO: When using the '0' value as an input, the input will be disconnected and no signal will appear on the output.

7.9.2. Query the Connected Source

Command and Response

- ▶ GET /V1/MEDIA/USB/XP/H1.ConnectedSource
- ◀ pw /V1/MEDIA/USB/XP/H1.ConnectedSource=<host>

Parameters

Parameter	Parameter description	Values	Value description
<host>	USB Host	U1-U4	USB-C and USB-B port number

Example

- ▶ GET /V1/MEDIA/USB/XP/H1.ConnectedSource
- ◀ pw /V1/MEDIA/USB/XP/H1.ConnectedSource=U4

7.9.3. Query the Connected Destinations

Command and Response *#autoselect*

- ▶ GET /V1/MEDIA/USB/XP/<host>.ConnectedDestinations
- ◀ pr /V1/MEDIA/USB/XP/<host>.ConnectedDestinations=H1

Parameters

Parameter	Parameter description	Values	Value description
<host>	USB Host	U1-U4	USB-C and USB-B port number

Example

- ▶ GET /V1/MEDIA/USB/XP/U3.ConnectedDestinations
- ◀ pr /V1/MEDIA/USB/XP/U3.ConnectedDestinations=H1

7.9.4. Lock the USB Port

Command and Response *#lock*

- ▶ SET /V1/MEDIA/USB/XP/<usb_port>.Lock=<locked_state>
- ◀ pw /V1/MEDIA/USB/XP/<usb_port>.Lock=<locked_state>

Parameters

Parameter	Parameter description	Values	Value description
<usb_port>	USB Port	U1-U4 H1	USB-C and USB-B port number USB hub
<locked_state>	Locked state	true false	The port is locked The port is unlocked

Example

- ▶ SET /V1/MEDIA/USB/XP/U2.Lock=false
- ◀ pw /V1/MEDIA/USB/XP/U2.Lock=false

7.9.5. Setting the 5V Sending to the USB Peripherals

The 5V power towards the USB A-type ports can be enabled or disabled as follows:

Command and Response

- ▶ SET /V1/MEDIA/USB/H1/<device_id>.Power5VMode=<device_pwr>
- ◀ pw /V1/MEDIA/USB/H1/<device_id>.Power5VMode=<device_pwr>

Parameters

Parameter	Parameter description	Values	Value description
<device_id>	USB A-type port	D1-D4	Downstream port number
		Auto	The host controls the 5V power sending.
		Off	Disable 5V power on USB downstream port

Example

- ▶ SET /V1/MEDIA/USB/H1/D1.Power5VMode=Auto
- ◀ pw /V1/MEDIA/USB/H1/D1.Power5VMode=Auto

7.9.6. Set the USB Autoselect Policy

DIFFERENCE: Last detect and first detect mode is available only from FW package 1.1.0b7.

Command and Response *#new*

- ▶ SET /V1/MEDIA/USB/AUTOSELECT/H1.Policy=<op_mode>
- ◀ pw /V1/MEDIA/USB/AUTOSELECT/H1.Policy=<op_mode>

Parameters

Parameter	Parameter description	Values	Value description
<op_mode>	Operation mode	Off	The autoselect function is disabled.
		Last Detect	Always the last attached input is switched to the output automatically.
		First Detect	The first active USB input is selected.
		Follow video	Follows the video crosspoint state automatically.

Example

- ▶ SET /V1/MEDIA/USB/AUTOSELECT/H1.Policy=Follow video
- ◀ pw /V1/MEDIA/USB/AUTOSELECT/H1.Policy=Follow video

7.9.7. Set the Followed Video Port to Autoselect

Command and Response

- ▶ SET /V1/MEDIA/USB/AUTOSELECT/H1.VideoFollowPort=<out>
- ◀ pw /V1/MEDIA/USB/AUTOSELECT/H1.VideoFollowPort=<out>

Example

- ▶ SET /V1/MEDIA/USB/AUTOSELECT/H1.VideoFollowPort=01
- ◀ pw /V1/MEDIA/USB/AUTOSELECT/H1.VideoFollowPort=01

7.9.8. Change the Autoselect Included USB Ports

DIFFERENCE: This command is available only from FW package 1.1.0b7.

Command and Response

- ▶ SET /V1/MEDIA/USB/AUTOSELECT/H1/<host>.Included=<state>
- ◀ pw /V1/MEDIA/USB/AUTOSELECT/H1/<host>.Included=<state>

Parameters

Parameter	Parameter description	Values	Value description
<host>	USB Host	U1-U4	USB-C and USB-B port number
<state>	The chosen input is ignored from the autoselect process or not.	true	The port is included in autoselect.
		false	The autoselect function ignores that port.

Example

- ▶ SET /V1/MEDIA/USB/AUTOSELECT/H1/U1.Included=true
- ◀ pw /V1/MEDIA/USB/AUTOSELECT/H1/U1.Included=true

7.9.9. Change the USB Port Priority

DIFFERENCE: This command is available only from FW package 1.1.0b7.

Command and Response

- ▶ SET /V1/MEDIA/USB/AUTOSELECT/H1/<host>.Priority=<prio_num>
- ◀ pw /V1/MEDIA/USB/AUTOSELECT/H1/<host>.Priority=<prio_num>

Parameters

Parameter	Parameter description	Values	Value description
<host>	USB Host	U1-U4	USB-C and USB-B port number
<prio_num>	Priority number from 1 to 100, equal numbers are allowed.	1-100	1: the highest priority 100: the lowest priority

Example

- ▶ SET /V1/MEDIA/USB/AUTOSELECT/H1/U1.Priority=51
- ◀ pw /V1/MEDIA/USB/AUTOSELECT/H1/U1.Priority=51

7.10. USB Port Settings - USB-C Related Commands

7.10.1. Set USB-C Power

Command and Response #power

- ▶ SET /V1/SYS/MB/USBCPOWER.PowerLimit=<power>
- ◀ pw /V1/SYS/MB/USBCPOWER.PowerLimit=<power>

Parameters

Parameter	Parameter description	Values	Value description
<power>	Power limit to the USB-C ports	0 1 2	Equal output power on the two ports (30W each) Port1 maximum, Port2 minimum (60W for U1) Port1 minimum, Port2 maximum (60W for U2)

Example

- ▶ SET /V1/SYS/MB/USBCPOWER.PowerLimit=2
- ◀ pw /V1/SYS/MB/USBCPOWER.PowerLimit=2

7.10.2. Set Displayport Alternate Mode Policy

Command and Response

- ▶ SET /V1/MEDIA/USB/<usb_port>.DpAltModePolicy=<dp_policy>
- ◀ pw /V1/MEDIA/USB/<usb_port>.DpAltModePolicy=<dp_policy>

Parameters

Parameter	Parameter description	Values	Value description
<usb-c_port>	USB-C port number	U1-U2	USB-C port number
<dp_policy>	The preferred video or USB data transmission	Auto Force C Force D	Auto: Taurus offers both operation modes described below. BYOD device can choose between the two. Neither USB3, nor 4 lane DP Alt mode operation (4K@60) is guaranteed. BYOD devices supporting USB3.x usually choose shared mode: USB3.1 and 2 lane DP. Prefer video: all the four lanes reserved for video transmission, USB 3.1 data transmission does not operate. Prefer USB 3.1: 2 lanes are reserved for USB 3.1, 2 lanes for video.

Example

- ▶ SET /V1/MEDIA/USB/U2.DpAltModePolicy=Auto
- ◀ pw /V1/MEDIA/USB/U2.DpAltModePolicy=Auto

ATTENTION! Changing DpAltModePolicy is recommended before connecting a computer to the input.

7.10.3. Query the Host Alternate Mode Support

Command and Response

- ▶ GET /V1/MEDIA/USB/<usb-c_port>.HostSupportsDpAltMode
- ◀ pr /V1/MEDIA/USB/<usb-c_port>.HostSupportsDpAltMode=<altmode_support>

Parameters

Parameter	Parameter description	Value	Value description
<usb-c_port>	USB-C port number	U1-U2	USB-C port number
<altmode_support>		False True	The host does not support the alternate mode. The host supports the alternate mode.

Example

- ▶ GET /V1/MEDIA/USB/U1.HostSupportsDpAltMode
- ◀ pr /V1/MEDIA/USB/U1.HostSupportsDpAltMode=true

7.10.4. Query the Status of the Alternate Mode

Command and Response #dpaltmode #alternatemode #displayportalternatemode

- ▶ GET /V1/MEDIA/USB/<usb-c_port>.ActiveAltMode
- ◀ pr /V1/MEDIA/USB/<usb-c_port>.ActiveAltMode=<altmode_state>

Parameters

Parameter	Parameter description	Value	Value description
<usb-c_port>	USB-C port number	U1-U2	USB-C port number
<altmode_state>		N/A None DP	The host is not connected DP Alt mode is not active DP Alt mode is active.

Example

- ▶ GET /V1/MEDIA/USB/U2.ActiveAltMode
- ◀ pr /V1/MEDIA/USB/U2.ActiveAltMode=DP

7.10.5. Query the Port Data Role

Command and Response

- ▶ GET /V1/MEDIA/USB/<usb_port>.ActivePortDataRole
- ◀ pr /V1/MEDIA/USB/<usb_port>.ActivePortDataRole=<data_role>

Parameters

Parameter	Parameter description	Values	Value description
<usb-c_port>	USB-C port number	U1-U2	USB-C port number
<data_role>		N/A	No
		DFP	Downstream Facing Port (usually a Host / HUB ports) The port data role is configured as USB Host. This is for build-up the connection (USB data transmission operates after the data role swap)
		UFP	Upstream Facing Port (usually a device)

Example

- ▶ GET /V1/MEDIA/USB/U2.ActivePortDataRole
- ◀ pr /V1/MEDIA/USB/U2.ActivePortDataRole=UFP

7.10.6. Query the Port Power Role

Command and Response #power

- ▶ GET /V1/MEDIA/USB/<usb_port>.ActivePortPowerRole
- ◀ pr /V1/MEDIA/USB/<usb_port>.ActivePortPowerRole=<power_role>

Parameters

Parameter	Parameter description	Values	Value description
<usb-c_port>	USB-C port number	U1-U2	USB-C port number
<power_role>		N/A	No information about the power role.
		Sink	The port is configured as a sink.
		Source	The port is configured as a source

Example

- ▶ GET /V1/MEDIA/USB/U2.ActivePortPowerRole
- ◀ pr /V1/MEDIA/USB/U2.ActivePortPowerRole=Source

7.10.7. Set Port Power Role

Command and Response

- ▶ SET /V1/MEDIA/USB/<usb-c_port>.PortPowerRoleSetting=<power_role>
- ◀ pw /V1/MEDIA/USB/<usb_port>.PortPowerRoleSetting=<power_role>

Parameters

Parameter	Parameter description	Values	Value description
<usb-c_port>	USB-C port number	U1-U2	USB-C port number
<power_role>		Sink	The port is configured as a sink.
		Source	The port is configured as a source
		Dual Role	The port is configured Dual Power Role mode.

Example

- ▶ SET /V1/MEDIA/USB/U1.PortPowerRoleSetting=Dual Role
- ◀ pw /V1/MEDIA/USB/U1.PortPowerRoleSetting=Dual Role

7.11. EDID Management

7.11.1. Query the Emulated EDIDs

Command and Response *#edid*

- ▶ GET /V1/EDID.EdidStatus
- ◀ pr /V1/EDID.EdidStatus=<source>:E1;<source>:E2; <source>:E3;<source>:E4

Parameters

Parameter	Parameter description	Values	Value description
<source>	Source EDID memory place	F1-F120 U1-U14 D1-D2	Factory EDIDs User EDIDs Dynamic EDIDs

Example

- ▶ GET /V1/EDID.EdidStatus
- ◀ pr /V1/EDID.EdidStatus=F89:E1;D1:E2;D1:E3;D1:E4

Emulated EDID memory for input port is listed with the EDID number that is currently emulated on the input.

7.11.2. Query the Validity of a Dynamic EDID

Command and Response

- ▶ GET /V1/EDID/D/D1.Validity
- ◀ pr /V1/EDID/D/D1.Validity=<validity>

Parameters

If the <validity> parameter is **true**, the EDID is valid. If the parameter is **false**, the EDID is invalid.

Example

- ▶ GET /V1/EDID/D/D1.Validity
- ◀ pr /V1/EDID/D/D1.Validity=true

The 'Validity' property is true, valid EDID is stored in D1 memory place.

7.11.3. Query the Preferred Resolution of a User EDID

Command and Response

- ▶ GET /V1/EDID/U/<user_edid>.PreferredResolution
- ◀ pr /V1/EDID/U/<user_edid>.PreferredResolution=<preferred_resolution>

Example

- ▶ GET /V1/EDID/U/U2.PreferredResolution
- ◀ pr /V1/EDID/U/U2.PreferredResolution=1920x1080p60.00Hz

■ INFO: Use the **Manufacturer** and **MonitorName** properties to query further information.

7.11.4. Emulating an EDID to an Input Port

Command and Response

- ▶ CALL /V1/EDID:switch(<source>:<destination>)
- ◀ m0 /V1/EDID:switch

Parameters

Parameter	Parameter description	Values	Value description
<source>	Source EDID memory place	F1-F120 U1-U14 D1-D2	Factory EDIDs User EDIDs Dynamic EDIDs
<destination>	The emulated EDID memory of the desired input port	U1-U14	User EDIDs

Example

- ▶ CALL /V1/EDID:switch(F49:E2)
- ◀ m0 /V1/EDID:switch

7.11.5. Emulating an EDID to All Input Ports

Command and Response

- ▶ CALL /V1/EDID:switchAll(<source>)
- ◀ m0 /V1/EDID:switchAll

Parameters

Parameter	Parameter description	Values	Value description
<source>	Source EDID memory place	F1-F148 U1-U100 D1-D2	Factory EDIDs User EDIDs Dynamic EDIDs

Example

- ▶ CALL /V1/EDID:switchAll(F47)
- ◀ m0 /V1/EDID:switchAll

7.11.6. Copy an EDID to User Memory

Command and Response

- ▶ CALL /V1/EDID:copy(<source>:<destination>)
- ◀ m0 /V1/EDID:copy

Parameters

Parameter	Parameter description	Values	Value description
<source>	Source EDID memory place	F1-F148 U1-U100 D1-D2	Factory EDIDs User EDIDs Dynamic EDIDs
<destination>	The emulated EDID memory of the desired input port	U1-U100	User EDIDs

Example

- ▶ CALL /V1/EDID:copy(F1:U2)
- ◀ m0 /V1/EDID:copy

7.11.7. Deleting an EDID from User Memory

Command and Response

- ▶ CALL /V1/EDID:delete(<user_edid>)
- ◀ m0 /V1/EDID:delete

Parameters

Parameter	Parameter description	Values	Value description
<user_edid>	The emulated EDID memory of the desired input port.	U1-U14	User EDIDs

Example

- ▶ CALL /V1/EDID:delete(U2)
- ◀ m0 /V1/EDID:delete

7.11.8. Resetting the Emulated EDIDs

Command and Response

- ▶ CALL /V1/EDID:reset()
- ◀ m0 /V1/EDID:reset

Parameters

Parameter	Parameter description	Values	Value description
<user_edid>	The emulated EDID memory of the desired input port.	U1-U14	User EDIDs

Example

- ▶ CALL /V1/EDID:reset()
- ◀ m0 /V1/EDID:reset

Calling this method switches all emulated EDIDs to factory default one. See the table in the [Factory EDID List](#) section.

7.12. Ethernet Port Configuration

7.12.1. Set the DHCP State

ATTENTION! When you change a network property the new value is stored but the **applySettings** method must be called always to apply the new settings. When two or more network parameters are changed the **applySettings** method is enough to call once as a final step; it results the device to reboot.

Command and Response *#dhcp #network #ipaddress*

- ▶ SET /V1/MANAGEMENT/NETWORK.DhcpEnabled=<dhcp_status>
- ◀ pw /V1/MANAGEMENT/NETWORK.DhcpEnabled=<dhcp_status>

Parameters

If the <dhcp_status> parameter is **true**, the current IP address setting is DHCP, if the parameter is **false** the current IP address is static.

Example

- ▶ SET /V1/MANAGEMENT/NETWORK.DhcpEnabled=true
- ◀ pw /V1/MANAGEMENT/NETWORK.DhcpEnabled=true
- ▶ CALL /V1/MANAGEMENT/NETWORK:applySettings()
- ◀ m0 /V1/MANAGEMENT/NETWORK:applySettings

INFO: The **applySettings** method will save and apply the new value and results the device to reboot.

INFO: The current setting can be queried by using the [GET command](#).

7.12.2. Change the IP Address (Static)

Command and Response

- ▶ SET /V1/MANAGEMENT/NETWORK.StaticIpAddress=<IP_address>
- ◀ pw /V1/MANAGEMENT/NETWORK.StaticIpAddress=<IP_address>

Example

- ▶ SET /V1/MANAGEMENT/NETWORK.StaticIpAddress=192.168.0.85
- ◀ pw /V1/MANAGEMENT/NETWORK.StaticIpAddress=192.168.0.85
- ▶ CALL /V1/MANAGEMENT/NETWORK:applySettings()
- ◀ m0 /V1/MANAGEMENT/NETWORK:applySettings

INFO: The **applySettings** method will save and apply the new value and results the device to reboot.

INFO: The current setting can be queried by using the [GET command](#).

7.12.3. Change the Subnet Mask (Static)

Command and Response *#ipaddress*

- ▶ SET /V1/MANAGEMENT/NETWORK.StaticNetworkMask=<netmask>
- ◀ pw /V1/MANAGEMENT/NETWORK.StaticNetworkMask=<netmask>

Example

- ▶ SET /V1/MANAGEMENT/NETWORK.StaticNetworkMask=255.255.255.0
- ◀ pw /V1/MANAGEMENT/NETWORK.StaticNetworkMask=255.255.255.0
- ▶ CALL /V1/MANAGEMENT/NETWORK:applySettings()
- ◀ m0 /V1/MANAGEMENT/NETWORK:applySettings

INFO: The **applySettings** method will save and apply the new value and results the device to reboot.

INFO: The current setting can be queried by using the [GET command](#).

7.12.4. Change the Gateway Address (Static)

Command and Response

- ▶ SET /V1/MANAGEMENT/NETWORK.StaticGatewayAddress=<gw_address>
- ◀ pw /V1/MANAGEMENT/NETWORK.StaticGatewayAddress=<gw_address>

Example

- ▶ SET /V1/MANAGEMENT/NETWORK.StaticGatewayAddress=192.168.0.5
- ◀ pw /V1/MANAGEMENT/NETWORK.StaticGatewayAddress=192.168.0.5
- ▶ CALL /V1/MANAGEMENT/NETWORK:applySettings()
- ◀ m0 /V1/MANAGEMENT/NETWORK:applySettings

INFO: The **applySettings** method will save and apply the new value and results the extender to reboot.

INFO: The current setting can be queried by using the [GET command](#).

7.12.5. Apply Network Settings

Command and Response

- ▶ CALL /V1/MANAGEMENT/NETWORK:applySettings()
- ◀ m0 /V1/MANAGEMENT/NETWORK:applySettings

Example

- ▶ CALL /V1/MANAGEMENT/NETWORK:applySettings()
- ◀ m0 /V1/MANAGEMENT/NETWORK:applySettings

All network settings which are changed have been applied and network interface restarts.

7.13. GPIO Port Configuration

DIFFERENCE: GPIO-related commands are available only from FW package 1.1.0b7.

7.13.1. Querying the Direction of a GPIO Pin

Command and Response `#gpio #new`

- ▶ GET /V1/MEDIA/GPIO/<port>.Direction
- ◀ pw /V1/MEDIA/GPIO/<port>.Direction(<dir>)

Parameters

Parameter	Parameter description	Value	Value description
<dir>	The direction of the GPIO pin.	Input	input
		Output	output

Example

- ▶ GET /V1/MEDIA/GPIO/P1.Direction
- ◀ pw /V1/MEDIA/GPIO/P1.Direction=Input

7.13.2. Setting the Direction of a GPIO Pin

Command and Response

- ▶ SET /V1/MEDIA/GPIO/<port>.Direction(<dir>)
- ◀ pw /V1/MEDIA/GPIO/<port>.Direction(<dir>)

Parameters

See the previous section.

Example

- ▶ SET /V1/MEDIA/GPIO/P1.Direction=Input
- ◀ pw /V1/MEDIA/GPIO/P1.Direction=Input

7.13.3. Querying the Output Level of a GPIO Pin

Command and Response

- ▶ GET /V1/MEDIA/GPIO/<port>.Output
- ◀ pw /V1/MEDIA/GPIO/<port>.Output(<value>)

Parameters

Parameter	Parameter description	Value	Value description
<value>	The output value of the GPIO pin.	High	high level
		Low	low level

Example

- ▶ GET /V1/MEDIA/GPIO/P1.Output
- ◀ pw /V1/MEDIA/GPIO/P1.Output=Low

7.13.4. Setting the Output Level of a GPIO Pin

Command and Response

- ▶ SET /V1/MEDIA/GPIO/<port>.Output(<value>)
- ◀ pw /V1/MEDIA/GPIO/<port>.Output(<value>)

Parameters

See the previous section.

Example

- ▶ SET /V1/MEDIA/GPIO/P1.Output=High
- ◀ pw /V1/MEDIA/GPIO/P1.Output=High

7.13.5. Setting the Output Level for a Specified Time

Command and Response

- ▶ CALL /V1/MEDIA/GPIO/<port>.interval(<value>;<time>)
- ◀ m0 /V1/MEDIA/GPIO/<port>.interval=

Parameters

Parameter	Parameter description	Value	Value description
<value>	The output value of the GPIO pin.	High	high level
		Low	low level
<time>	Duration of the desired value in seconds.	1-120	second

Example

- ▶ CALL /V1/MEDIA/GPIO/P1.interval(Low;1)
- ◀ m0 /V1/MEDIA/GPIO/P1.interval=

7.13.6. Toggling the Level of a GPIO Pin

The output level can be changed from high to low and low to high by the command below.

Command and Response

- ▶ CALL /V1/MEDIA/GPIO/<port>.toggle()
- ◀ m0 /V1/MEDIA/GPIO/<port>.toggle

Example

- ▶ CALL /V1/MEDIA/GPIO/P1.toggle()
- ◀ m0 /V1/MEDIA/GPIO/P1.toggle

7.14. OCS Port Configuration

DIFFERENCE: Occupancy sensor-related commands are available only from FW package 1.1.0b7.

7.14.1. Querying the Input Level of an OCS Pin

Command and Response *#ocs #new*

- ▶ GET /V1/MEDIA/OCS/P1.InputLevel
- ◀ pr /V1/MEDIA/OCS/P1.InputLevel=<value>

Parameters

Parameter	Parameter description	Value	Value description
<value>	The input value of the OCS pin.	High	high level
		Low	low level

Example

- ▶ GET /V1/MEDIA/OCS/P1.InputLevel
- ◀ pr /V1/MEDIA/OCS/P1.InputLevel=Low

7.14.2. Set the Sensor Type

Command and Response

- ▶ SET /V1/MEDIA/OCS/P1.SensorType=<sensor_type>
- ◀ pw /V1/MEDIA/OCS/P1.SensorType=<sensor_type>

Parameters

Parameter	Parameter description	Value	Value description
<sensor_type>	It defines that the low or high input level means the occupancy.	Active low	Occupancy status is 'Occupied' when the input level is low.
		Active high	Occupancy status is 'Occupied' when the input level is high (default value).

Example

- ▶ SET /V1/MEDIA/OCS/P1.SensorType=Active low
- ◀ pw /V1/MEDIA/OCS/P1.SensorType=Active low

7.14.3. Querying the Reported OCS State

Command and Response

- ▶ GET /V1/MEDIA/OCS/P1.State
- ◀ pr /V1/MEDIA/OCS/P1.State=<status>

Parameters

Parameter	Parameter description	Value	Value description
<status>	It reports the occupancy state of the room depending on the sensor type.	Free	When the SensorType=Active high and the Inputlevel=Low or when SensorType=Active low and Inputlevel=High
		Occupied	When the SensorType=Active high and the Inputlevel=High or when SensorType=Active low and Inputlevel=Low

Example

- ▶ GET /V1/MEDIA/OCS/P1.State
- ◀ pr /V1/MEDIA/OCS/P1.State=Free

7.15. LW3 Commands - Quick Summary

System Commands

Set the Device Label

- ▶ SET·/V1/MANAGEMENT/LABEL.DeviceLabel=<custom_name>

Reset the Device

- ▶ CALL·/V1/SYS:restart()

Restore the Factory Default Settings

- ▶ CALL·/V1/SYS:factoryDefaults()

Querying the Firmware Package Version

- ▶ GET·/V1/MANAGEMENT/UID/PACKAGE.Version

Control Lock

- ▶ SET·/V1/MANAGEMENT/UI.ControlLock=<lock_status>

Set Current Time

- ▶ CALL·/V1/MANAGEMENT/DATETIME:setTime(<current_time>)

Video Port Settings - General

Switch Video Input

- ▶ CALL·/V1/MEDIA/VIDEO/XP:switch(<in>:<out>)

Switch an Input to All Outputs

- ▶ CALL·/V1/MEDIA/VIDEO/XP:switchAll(<input>)

Lock the Video Port

- ▶ SET·/V1/MEDIA/VIDEO/XP/<port>.Lock=<locked_state>

Mute the Video Port

- ▶ SET·/V1/MEDIA/VIDEO/XP/<port>.Mute=<muted_state>

Set the Autoselect Policy

- ▶ SET·/V1/MEDIA/VIDEO/AUTOSELECT/<out>.Policy=<autoselect_mode>

Change the Autoselect Included Input Ports

- ▶ SET·/V1/MEDIA/VIDEO/AUTOSELECT/<out>/<in>.Included=<state>

Change the Input Port Priority

- ▶ SET·/V1/MEDIA/VIDEO/AUTOSELECT/<out>/<in>.Priority=<prio_num>

Query the Connected Source

- ▶ GET·/V1/MEDIA/VIDEO/XP/<out>.ConnectedSource

Query the Connected Destinations

- ▶ GET·/V1/MEDIA/VIDEO/XP/<n>.ConnectedDestinations

Query the Input Switchable Ability

- ▶ GET·/V1/MEDIA/VIDEO/XP/<out>/SWITCHABLE.<in>

SignalPresent

- ▶ GET·/V1/MEDIA/VIDEO/<port>.SignalPresent

HDCP Setting (Input Port)

- ▶ SET·/V1/MEDIA/VIDEO/<in>/HDCP.AllowedHdcpVersion=<allowed_hdcp>

HdcpMode

- ▶ SET·/V1/MEDIA/VIDEO/<out>.HdcpMode=<hdcp_mode>

EmbeddedAudioPresent

- ▶ GET·/V1/MEDIA/VIDEO/<port>.EmbeddedAudioPresent

EmbeddedAudioMute

- ▶ SET·/V1/MEDIA/VIDEO/<port>.EmbeddedAudioMute=<mute_state>

OutputSignalType

- ▶ SET·/V1/MEDIA/VIDEO/<out>.OutputSignalType=<signal_type>

Output5VMode

- ▶ SET·/V1/MEDIA/VIDEO/<out>.Output5VMode=<5V_pwr>

Welcome Screen Settings

Display Welcome Screen Image

- ▶ SET·/V1/SYS/MB/INTERNALVIDEOSRC.ShowSplashImage=<image_state>

Display Welcome Screen Text

- ▶ SET·/V1/SYS/MB/INTERNALVIDEOSRC.ShowInfoMessage=<text_state>

Set Welcome Screen Text

- ▶ SET·/V1/SYS/MB/INTERNALVIDEOSRC.InfoMessage =<text>

Video Port Settings - USB-C Related Commands

Restart Link Training

- ▶ CALL /V1/MEDIA/VIDEO/I1/DP:restartLinkTraining()

Audio Port Settings**Switch Audio Input**

- ▶ `CALL·/V1/MEDIA/AUDIO/XP:switch(<audio_in>:O3)`

Query the Connected Source

- ▶ `GET·/V1/MEDIA/AUDIO/XP/O3.ConnectedSource`

Query the Connected Destinations

- ▶ `GET·/V1/MEDIA/AUDIO/XP/<audio_in>.ConnectedDestinations`

Set Autoselect Operation Mode

- ▶ `SET·/V1/MEDIA/AUDIO/AUTOSELECT/O3.Policy=<op_mode>`

Set the Followed Video Port to Autoselect

- ▶ `SET·/V1/MEDIA/AUDIO/AUTOSELECT/O3.VideoFollowPort=<out>`

Lock the Audio Port

- ▶ `SET·/V1/MEDIA/AUDIO/XP/<audio_port>.Lock=<locked_state>`

Mute the Audio Port 1.

- ▶ `SET·/V1/MEDIA/AUDIO/XP/<audio_port>.Mute=<muted_state>`

Mute the Audio Port 2.

- ▶ `SET·/V1/MEDIA/AUDIO/O3.Mute=<muted_state>`

Query the Audio Signal Presence

- ▶ `GET·/V1/MEDIA/AUDIO/<audio_port>.SignalPresent`

Analog Audio Output Volume (dB) Setting

- ▶ `SET·/V1/MEDIA/AUDIO/O3.VolumedB=<level>`

Analog Audio Output Volume Percent Setting

- ▶ `SET·/V1/MEDIA/AUDIO/O3.VolumePercent=<percent>`

Setting the Balance

- ▶ `SET·/V1/MEDIA/AUDIO/O3.Balance=<level>`

Analog Audio Output Level Settings by Steps (dB)

- ▶ `CALL·/V1/MEDIA/AUDIO/O3:stepVolumedB(<step>)`

Analog Audio Output Level Settings by Steps in Percent

- ▶ `CALL·/V1/MEDIA/AUDIO/O3:stepVolumePercent(<step>)`

Analog Audio Output Balance by Steps

- ▶ `CALL·/V1/MEDIA/AUDIO/O3:stepBalance(<step>)`

USB Port Settings**Switch USB Input**

- ▶ `CALL·/V1/MEDIA/USB/XP:switch(<host>:H1)`

Query the Connected Source

- ▶ `GET·/V1/MEDIA/USB/XP/H1.ConnectedSource`

Query the Connected Destinations

- ▶ `GET·/V1/MEDIA/USB/XP/<host>.ConnectedDestinations`

Lock the USB Port

- ▶ `SET·/V1/MEDIA/USB/XP/<usb_port>.Lock=<locked_state>`

Setting the 5V Sending to the USB Peripherals

- ▶ `SET·/V1/MEDIA/USB/H1/<device_id>.Power5VMode=<device_pwr>`

Set the USB Autoselect Policy

- ▶ `SET·/V1/MEDIA/USB/AUTOSELECT/H1.Policy=<op_mode>`

Set the Followed Video Port to Autoselect

- ▶ `SET·/V1/MEDIA/USB/AUTOSELECT/H1.VideoFollowPort=<out>`

Change the Autoselect Included USB Ports

- ▶ `SET·/V1/MEDIA/USB/AUTOSELECT/H1/<host>.Included=<state>`

Change the USB Port Priority

- ▶ `SET·/V1/MEDIA/USB/AUTOSELECT/H1/<host>.Priority=<prio_num>`

USB Port Settings - USB-C Related Commands**Set USB-C Power**

- ▶ `SET·/V1/SYS/MB/USBCPOWER.PowerLimit=<power>`

Set Displayport Alternate Mode Policy

- ▶ `SET·/V1/MEDIA/USB/<usb_port>.DpAltModePolicy=<dp_policy>`

Query the Host Alternate Mode Support

- ▶ `GET·/V1/MEDIA/USB/<usb-c_port>.HostSupportsDpAltMode`

Query the Status of the Alternate Mode

- ▶ `GET·/V1/MEDIA/USB/<usb-c_port>.ActiveAltMode`

Query the Port Data Role

- ▶ `GET·/V1/MEDIA/USB/<usb_port>.ActivePortDataRole`

Query the Port Power Role

- ▶ `GET·/V1/MEDIA/USB/<usb_port>.ActivePortPowerRole`

Set Port Power Role

- ▶ SET:/V1/MEDIA/USB/<usb-c_port>.PortPowerRoleSetting=<power_role>

EDID Management**Query the Emulated EDIDs**

- ▶ GET:/V1/EDID.EdidStatus

Query the Validity of a Dynamic EDID

- ▶ GET:/V1/EDID/D/D1.Validity

Query the Preferred Resolution of a User EDID

- ▶ GET:/V1/EDID/U/<user_edid>.PreferredResolution

Emulating an EDID to an Input Port

- ▶ CALL:/V1/EDID:switch(<source>:<destination>)

Emulating an EDID to All Input Ports

- ▶ CALL:/V1/EDID:switchAll(<source>)

Copy an EDID to User Memory

- ▶ CALL:/V1/EDID:copy(<source>:<destination>)

Deleting an EDID from User Memory

- ▶ CALL:/V1/EDID:delete(<user_edid>)

Resetting the Emulated EDIDs

- ▶ CALL:/V1/EDID:reset()

Ethernet Port Configuration**Set the DHCP State**

- ▶ SET:/V1/MANAGEMENT/NETWORK.DhcpEnabled=<dhcp_status>

Change the IP Address (Static)

- ▶ SET:/V1/MANAGEMENT/NETWORK.StaticIpAddress=<IP_address>

Change the Subnet Mask (Static)

- ▶ SET:/V1/MANAGEMENT/NETWORK.StaticNetworkMask=<netmask>

Change the Gateway Address (Static)

- ▶ SET:/V1/MANAGEMENT/NETWORK.StaticGatewayAddress=<gw_address>

Apply Network Settings

- ▶ CALL:/V1/MANAGEMENT/NETWORK:applySettings()

GPIO Port Configuration**Querying the Direction of a GPIO Pin**

- ▶ GET:/V1/MEDIA/GPIO/<port>.Direction

Setting the Direction of a GPIO Pin

- ▶ SET:/V1/MEDIA/GPIO/<port>.Direction(<dir>)

Querying the Output Level of a GPIO Pin

- ▶ GET:/V1/MEDIA/GPIO/<port>.Output

Setting the Output Level of a GPIO Pin

- ▶ SET:/V1/MEDIA/GPIO/<port>.Output(<value>)

Setting the Output Level for a Specified Time

- ▶ CALL:/V1/MEDIA/GPIO/<port>:interval(<value>;<time>)

Toggleing the Level of a GPIO Pin

- ▶ CALL:/V1/MEDIA/GPIO/<port>:toggle()

OCS Port Configuration**Querying the Input Level of a OCS Pin**

- ▶ GET:/V1/MEDIA/OCS/P1.Inputlevel

Set the Sensor Type

- ▶ SET:/V1/MEDIA/OCS/P1.SensorType=<sensor_type>

Querying the Reported OCS State

- ▶ GET:/V1/MEDIA/OCS/P1.State

8

Firmware Upgrade

This chapter is meant to help customers perform firmware upgrades on our products by giving a few tips on how to start and by explaining the features of the Lightware Device Updater v2 (LDU2) software. To get the latest software and firmware pack can be downloaded from www.lightware.com.

- ▶ INTRODUCTION
- ▶ PREPARATION
- ▶ RUNNING THE SOFTWARE
- ▶ THE UPGRADING STEPS
- ▶ IF THE UPGRADE IS NOT SUCCESSFUL

ATTENTION! While the firmware is being upgraded, the normal operation mode is suspended as the transmitter is switched to bootload mode. Signal processing is not performed. Do not interrupt the firmware upgrade. If any problem occurs, reboot the device and restart the process.

8.1. Introduction

Lightware Device Updater v2 (LDU2) software is the second generation of the LFP-based (Lightware Firmware Package) firmware upgrade process.

DIFFERENCE: The software can be used for uploading the packages with LFP2 extension only. LDU2 is not suitable for using LFP files, please use the LDU software for that firmware upgrade.

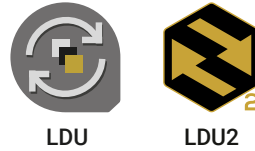

8.2. Preparation

Most Lightware devices can be controlled over more interfaces (e.g. Ethernet, USB, RS-232). But the firmware can be upgraded usually over one dedicated interface, which is the Ethernet in most cases.

If you want to upgrade the firmware of one or more devices you need the following:

- LFP2 file,
- LDU2 software installed on your PC or Mac.

Both can be downloaded from www.lightware.com/downloads.

Optionally, you can download the **release notes** file in HTML format.

8.2.1. About the Firmware Package (LFP2 File)

All the necessary tools and binary files are packed into the LFP2 package file. You need only this file to do the upgrade on your device.

- This allows the use of the same LFP2 package for different devices.
- The package contains all the necessary components, binary, and other files.
- The release notes is included in the LFP2 file which is displayed in the window where you select the firmware package file in LDU2.

8.2.2. LDU2 Installation

ATTENTION! Minimum system requirement: 2 GB RAM.

INFO: The Windows and the Mac application has the same look and functionality.

Download the software from www.lightware.com/downloads.

Installation in case of Windows OS

Run the installer. If the User Account Control displays a pop-up message click **Yes**.

Installation Modes

Normal install	Snapshot install
Available for Windows and macOS	Available for Windows
The installer can update only this instance	Cannot be updated
One updateable instance may exist for all users	Many different versions can be installed for all users

ATTENTION! Using the default Normal install is highly recommended.

INFO: If you have a previously installed version you will be prompted to remove the old version before installing the new one.

Installation in case of macOS X

Mount the DMG file with double clicking on it and drag the LDU2 icon over the Applications icon to copy the program into the Applications folder. If you want to copy LDU2 into another location just drag the icon over the desired folder.

INFO: This type of installer is equal with the **Normal install** of Windows.

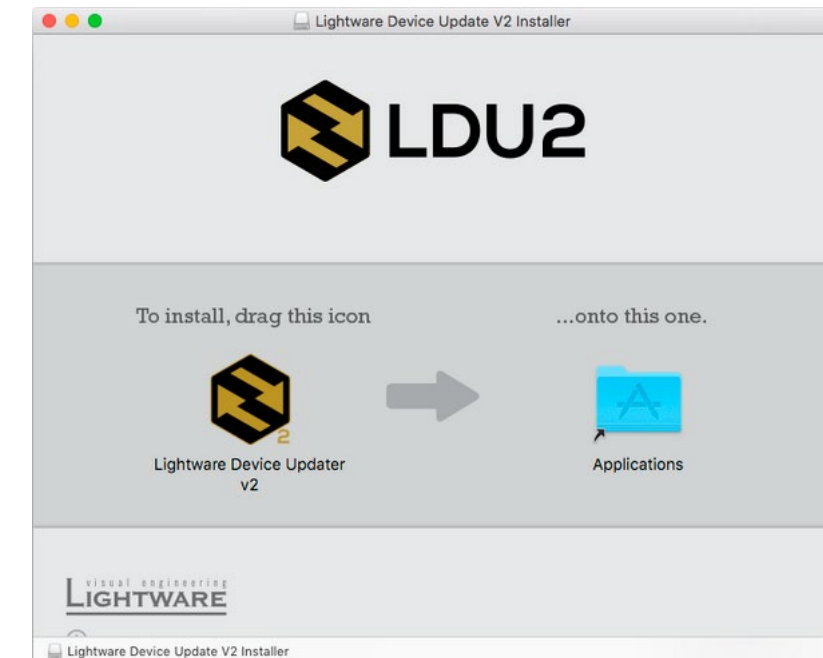

8.3. Running the Software

You have two options:

- **Starting the LDU2** by double-clicking on the shortcut/program file, or
- Double-clicking on an **LFP2 file**.

LDU2 Auto-Update

At startup, the software checks if a newer version is available on the web.

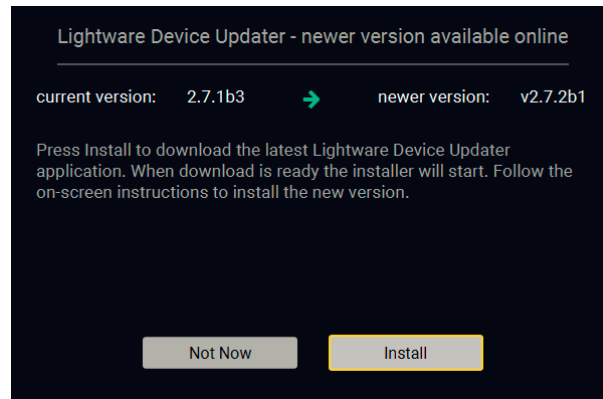

Main Screen

When the software is started by the shortcut, the device discovery screen appears. Press the **Search for devices** button to start finding the Lightware devices:

SEARCH FOR DEVICES

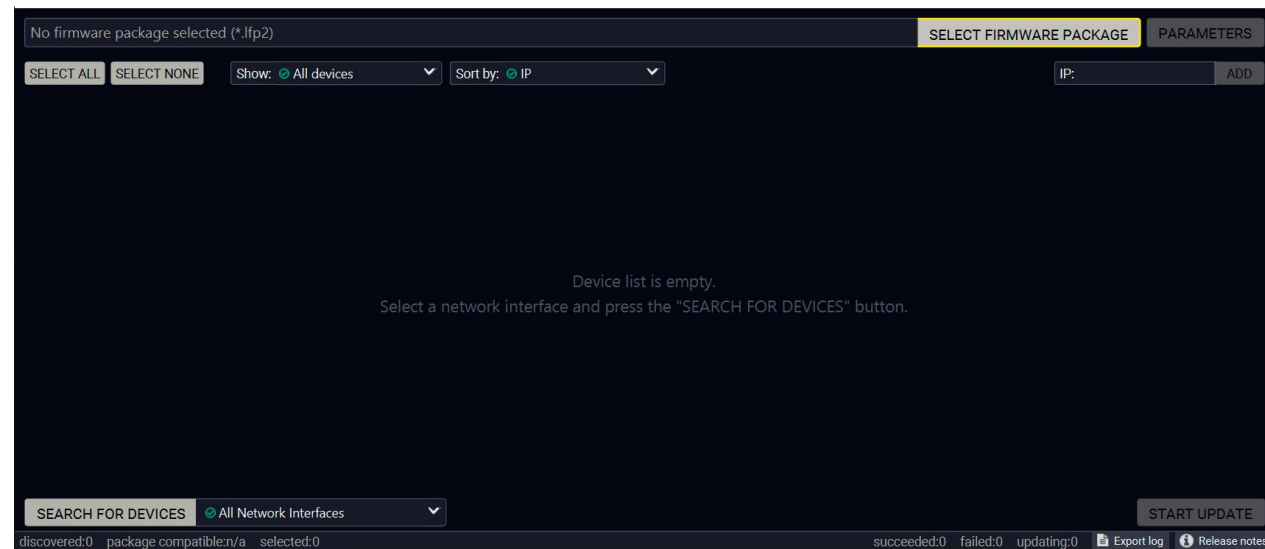

If you start the software by double-clicking on the LFP2 file, the firmware will be loaded. Press the **Search for devices** button; all the devices will be listed which are compatible with the selected firmware pack.

INFO: If you press the **Select firmware package** button, the release notes of the LFP2 file will be displayed in the right panel; see the [Step 1. Select the Firmware Package](#) section.

Device List

When the discovery has completed, the devices available on the network are listed in the application.

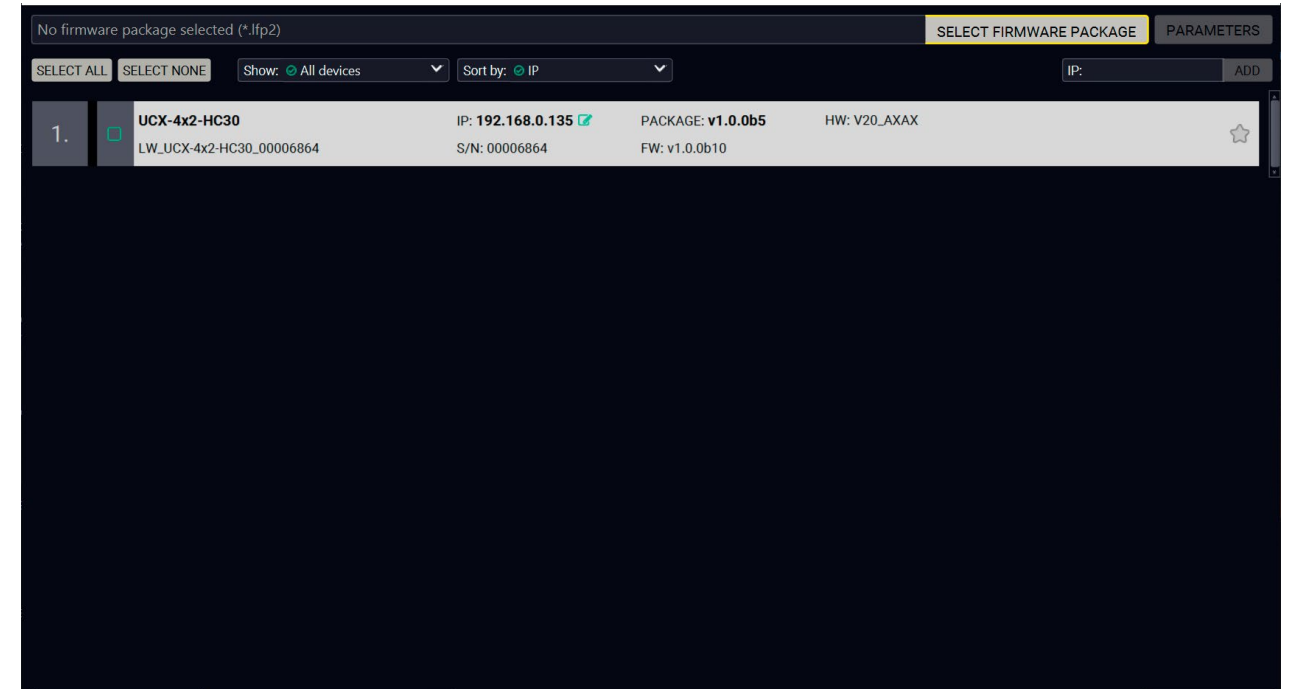

Legend of the Icons

- IP address editor** The IP address of the device can be changed in the pop-up window.
- Favorite device** The device has been marked, thus the IP address is stored. When a device is connected with that IP address, the star will highlighted in that line.
- Further information available** Device is unreachable. Change the IP address using the front panel LCD menu or the IP address editor of the LDU2.

8.4. The Upgrading Steps

ATTENTION! While the firmware is being upgraded, the normal operation mode is suspended as the device is switched to bootload mode. Signal processing is not performed. Do not interrupt the firmware upgrade. If any problem occurs, reboot the unit and restart the process.

Step 1. Select the Firmware Package.

Click on the **Select Firmware Package** button and navigate to the location where the LFP2 file was saved. When you click on the name of package, the preview of the release notes are displayed in the right panel.

SELECT FIRMWARE PACKAGE

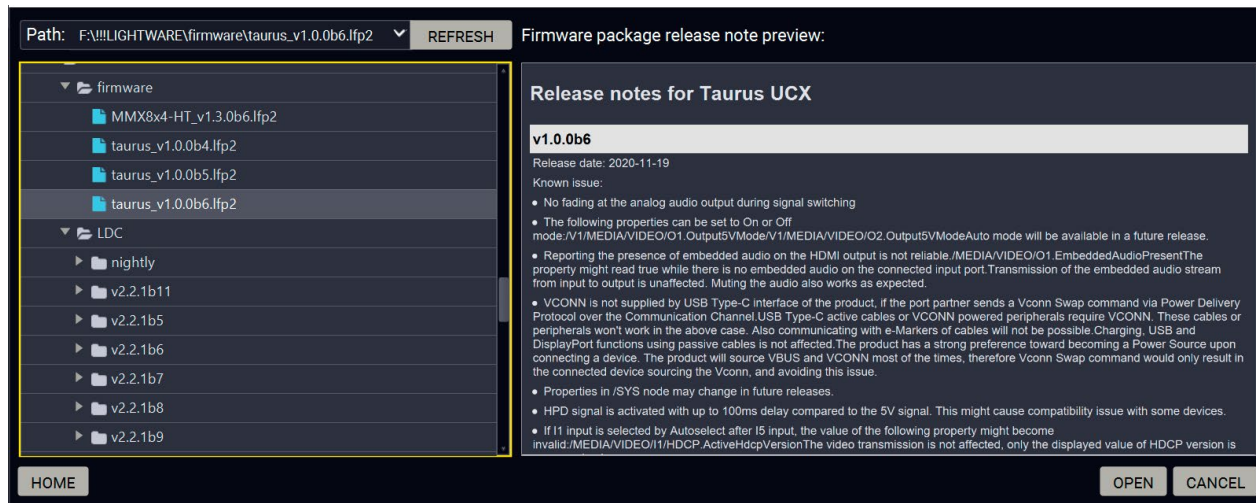

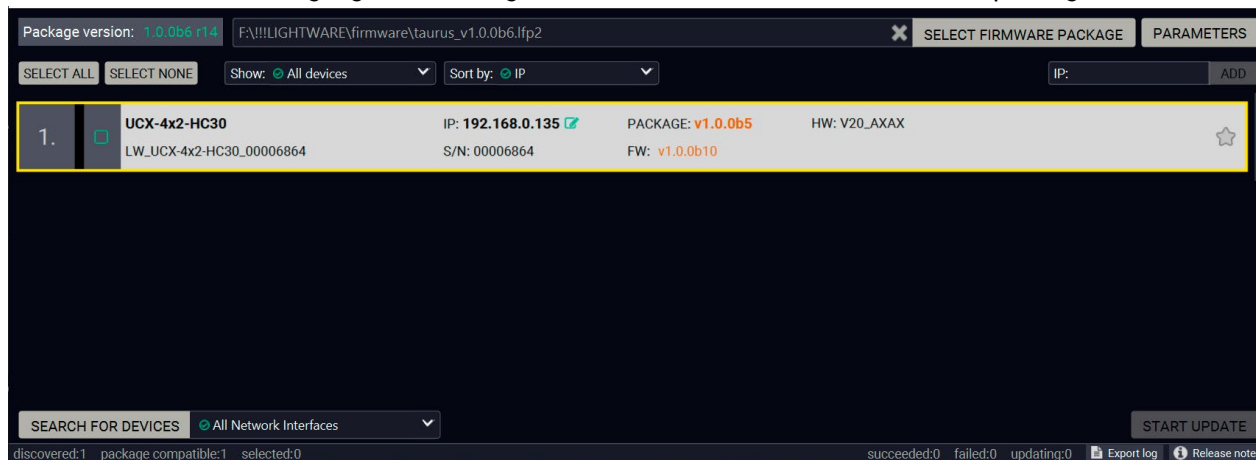

After the package file is loaded, the list is filtered to show the compatible devices only. The current firmware version of the device is highlighted in orange if it is different from the version of the package loaded.



DIFFERENCE: UCX-4x2-HC30D model is supported above v1.1.0 firmware package.

INFO: If you start the upgrade by double-clicking on the LFP file, above screen will be loaded right away.

The Meaning of the Symbols

-  Show details: The log about the upgrading process of the device can be displayed in a new window.
-  Service mode: The device is in bootload mode. Backup and restore cannot be performed in this case.

Step 2. Select the desired devices for upgrading.

Select the devices for upgrading; the selected line will be highlighted in green.

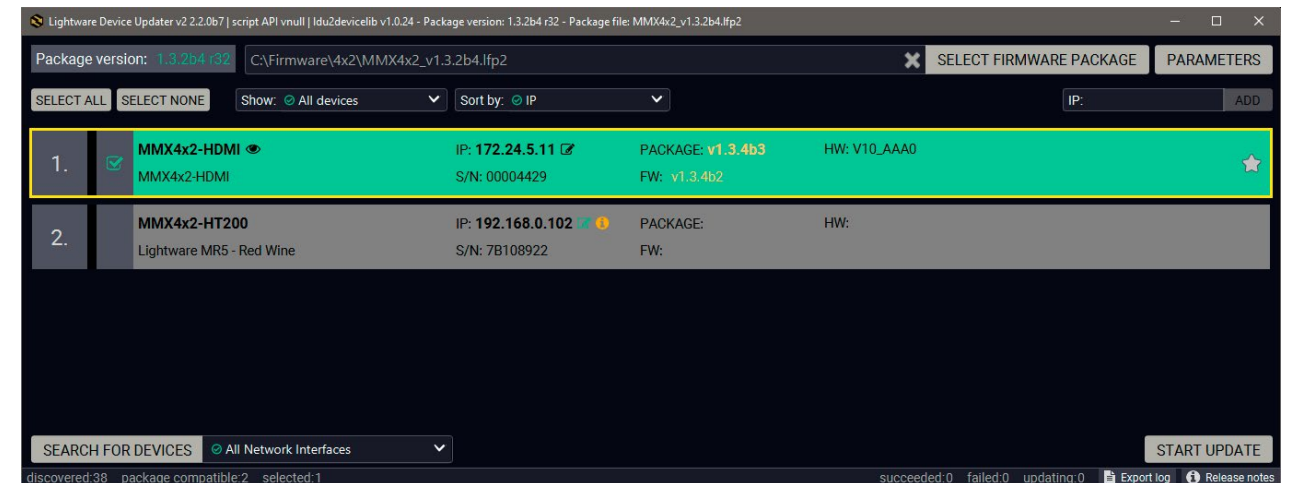

Step 3. Start the update and wait until it is finished.

Click on the **Start Update** button to start the procedure. The status is shown in percent in the right side of the device line and the overall process in the bottom progress bar.

START UPDATE

The device might reboot during the firmware upgrade procedure.

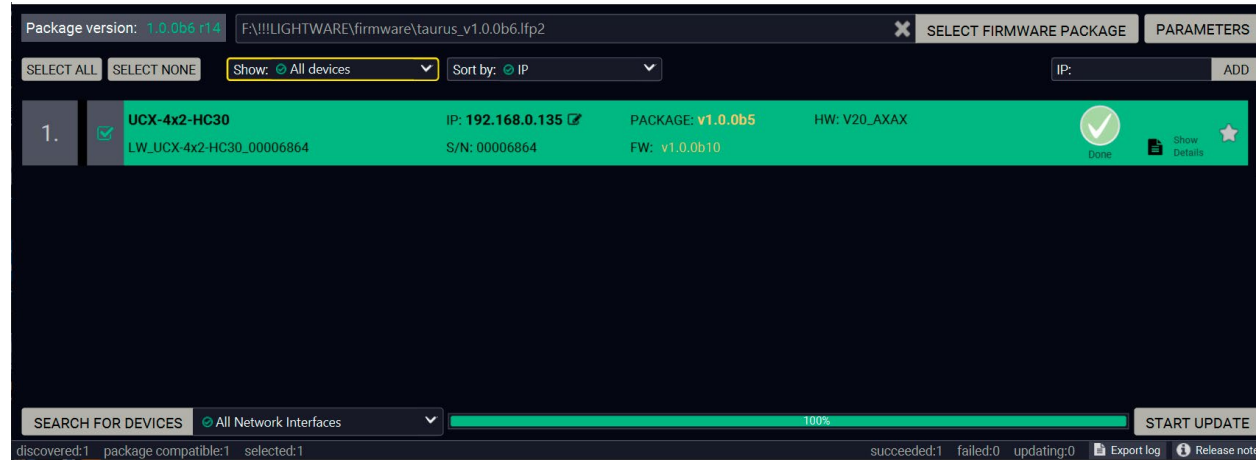

When the progress bar reaches 100% (Done is displayed at all devices), the upgrade of all devices are finished successfully and a message appears; you can close the software.

Step 5. Wait until the unit reboots with the new firmware.

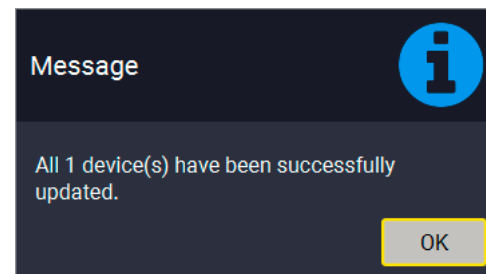
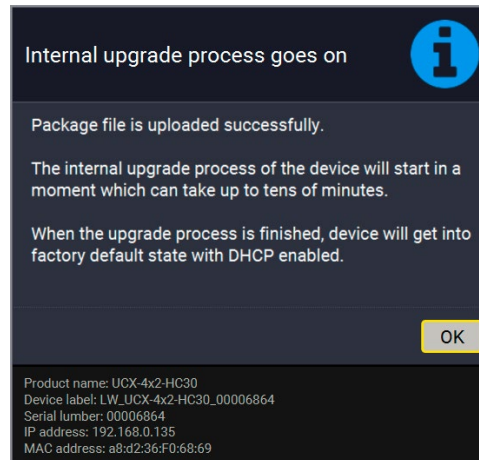

Once the firmware upgrade procedure is completed, the device is rebooted with the new firmware. Shutting down and restarting the device is recommended.

8.5. If the Upgrade is not successful

- Restart the process and try the upgrade again.
- If the device cannot be switched to bootload (firmware upgrade) mode, you can do that manually as written in the User's manual of the device. Please note that backup and restore cannot be performed in this case.
- If the backup cannot be created for some reason, you will get a message to continue the process without backup or stop the upgrade. A root cause can be that the desired device is already in bootload (firmware upgrade) mode, thus, the normal operation mode is suspended and backup cannot be made.
- If an upgrade is not successful, the **Export log** button becomes red. If you press the button, you can download the log file as a ZIP package which can be sent to Lightware Support if needed. The log files contain useful information about the circumstances to find the root cause. *#bootload*





9

Troubleshooting













Usually, if the system seems not to transport the signal as expected, the best strategy for troubleshooting is to check signal integrity through the whole signal chain starting from source side and moving forward to receiver end.





At first, check front panel LEDs and take the necessary steps according to their states. For more information about front panel LEDs of the switcher see [Front Panel Control](#) section.









Pictogram Legend

-  Section to connections/cabling.
-  Section to front panel operation.
-  Section to LDC software.
-  Section to LW3 protocol commands.

9.1. Use Case Studies

Symptom	Root cause	Action	Refer to	
Video layer				
No picture on the video output	Device(s) not powered properly	Check the switcher and the other devices if they are properly powered; try to unplug and reconnect them.		4.6
	Cable connection problem	Cables must fit very well, check all the connectors.		4.6
	No incoming signal	No video signal is present on the HDMI input ports. Check the source device and the HDMI cables.		4.6
	Not the proper video port is the active one	Check the video crosspoint settings.		3.1.1
				7.5.1
	Not the proper interface is the active one	If the source/display has more connectors, check if the proper interface is selected.		
	Output port is muted	Check the mute state of output ports.	 	7.5.4
	Display is not able to receive the video format	Check the emulated EDID and select another (e.g. emulate the display's EDID on the input port).		6.8.1
			7.11.4	
HDCP is disabled	Enable HDCP on input port(s) of the switcher.		6.6	
			7.5.12	
No picture on the video output + signal error rate is high, HDMI2.0 scrambling is disabled, clock rate is set 1:10	The source sends 4K signals, but the emulated EDID is not supported this resolution.		6.8.1	
			7.11.4	

Symptom	Root cause	Action	Refer to	
No 4K60 video signal on the USB-C input	The source is not able to send 4K60Hz	Check the documentation of the source, and the ability of the connected port. Certain USB-C ports are only for power and not for video transmission. The icons beside the port can help.		
	The source PC or BYOD resolution is not 4K60Hz	Check the source resolution and modify it, if it is necessary. Certain sources require restart.		
	The USB-C cable is not appropriate	The USB-C standard allows two cable types: the Full-Featured Type-C Cable Assembly or 2.0 Type-C Cable Assembly. The latter one will not operate with 4K60Hz.		4.5
				4.5
	Always use high-quality cable. The noname USB 3.1 Gen1-compatible cables could use only 2 SS channel instead of 4. The minimum cable requirement is USB 3.1 Gen1-compatibility and supporting Displayport HBR2.	The active Thunderbolt3 cable is not appropriate because it is not compatible backwards (with USB 3.x or DP). The passive TBT3 (20Gbps) cable could be proper when it supports USB3 Gen1 or Gen2 and Displayport.		4.5
				6.7.1
	Not proper Displayport alternate mode setting	Check if the DP Altmode Policy is set to Prefer video (Force C).		7.10.2

Symptom	Root cause	Action	Refer to	
USB layer				
The USB 3.x data transmission does not operate	The USB-C cable is not appropriate	The USB-C standard allows two cable types: the Full-Featured Type-C Cable Assembly or 2.0 Type-C Cable Assembly. The latter one will not operate for USB3 Gen1.		4.5
		Always use a high-quality cable. Noname cables not guaranteed the USB 3.x support.		4.5
		The active Thunderbolt3 cable is not appropriate because it is not compatible backwards (with USB 3.x). The passive TBT3 (20Gbps) cable could be proper when it supports USB3 Gen1 or Gen2.		4.5
	Not proper Displayport alternate mode setting	Check if the DPAltmode Policy is set to Prefer USB3 (Force D) or Auto.		6.7.1
				7.10.2
The USB 2.0 data transmission does not operate	IR drop level of the USB Type-C cable is low.	It can cause communication problems. Always use high quality cables.		4.5
The USB 2.0 data transmission or Power delivery do not operate or	If the resistor of the conductor in USB-C cable is too high, the voltage difference could be more, than 0.25V which can cause USB 2.0 or Power Delivery communication problems.	Always use high quality cables.		4.5
Power via USB-C				
BYOD charges slowly	The BYOD needs more than 60W	The error message will appear, because the UCX series maximum power capacity is 60W.		4.2.5
	Not proper the power setting of the USB-C port	Check the output power setting the connected port.		6.7.1

9.2. How to Speed Up the Troubleshooting Process?

Lightware’s technical support team is always working hard to provide the fastest support possible. Our team’s response time is one of the best in the industry and in the toughest of cases we can directly consult with the hardware or software engineer who designed the product to get the information from the most reliable source.

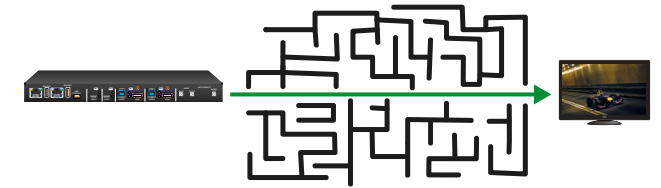

However, the troubleshooting process can be even faster... with your help.

There are certain pieces of information that push us in the right direction to finding the root cause of the problem. If we receive most of this information in the first e-mail or it is gathered at the time when you call us, then there is a pretty high chance that we will be able to respond with the final solution right away.

This information is the following:

- Schematic (a pdf version is preferred, but a hand drawing is sufficient).
- Serial number(s) of the device(s) (it is either printed somewhere on the box or you can query it in the Device Controller software or on the built-in website).
- Firmware versions of the devices (please note that there may be multiple CPUs or controllers in the device and we need to know all of their firmware versions, a screenshot is the best option).
- Cable lengths and types (in our experience, it’s usually the cable).
- Patch panels, gender changers or anything else in the signal path that can affect the transmission.
- Signal type (resolution, refresh rate, color space, deep color).
- Emulated EDID(s) (please save them as file and send them to us).
- Actions to take in order to re-create the problem (if we cannot reproduce the problem, it is hard for us to find the cause).
- Photo or video about the problem (‘image noise’ can mean many different things, it’s better if we see it too).
- Error logs from the Device Controller software.
- In the case of Event Manager issue the event file and/or backup file from the Device Controller software.

The more of the above information you can give us the better. Please send these information to the Lightware Support Team (support@lightware.com) to speed up the troubleshooting process.

10

Technologies

The following sections contain descriptions and useful technical information how the devices work in the background. The content is based on experiences and cases we met in the practice. These sections help to understand features and technical standards like the followings:

- ▶ [EDID MANAGEMENT](#)
- ▶ [HDCP MANAGEMENT](#)
- ▶ [PIXEL ACCURATE RECLOCKING](#)

10.1. EDID Management

10.1.1. Understanding the EDID

The Extended Display Identification Data (EDID) is the passport of display devices (monitors, TV sets, projectors). It contains information about the capabilities of the display, such as supported resolutions, refresh rates (these are called Detailed Timings), the type and manufacturer of the display device, etc.

After connecting a source to a display (DVI, HDMI, DP), the source reads out the EDID to determine the resolution and refresh rate of the image to be transmitted.

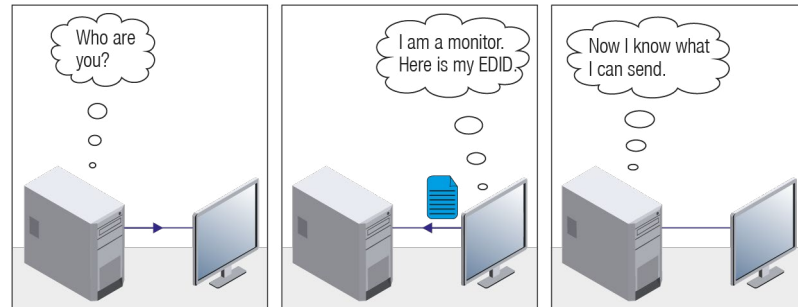

EDID Communication

Most DVI computer displays have 128-byte long EDID structure. However, Digital Televisions and HDMI capable displays may have another 128 bytes, which is called E-EDID and defined by CEA (Consumer Electronics Association). This extension contains information about additional Detailed Timings, audio capabilities, speaker allocation and HDMI capabilities. It is important to know that all HDMI capable devices must have CEA extension, but not all devices with CEA extension are HDMI capable.

Common Problems Related to EDID

Problem: “My system consists of the following: a computer, a Lightware device, a WUXGA (1920x1200) LCD monitor, and an SXGA (1280x1024) projector. I would like to see the same image on the monitor and the projector. What EDID should I choose on the Lightware device?”

Solution: If you want to see the image on both displays, you need to select the resolution of the smaller display (in this case SXGA), otherwise the smaller display may not show the higher resolution image.

Problem: “I have changed to a different EDID on an input port of the Lightware device to have a different resolution but nothing happens.”

Solution: Some graphics cards and video sources read out the EDID only after power-up and later they do not sense that EDID has been changed. You need to restart your source to make it read out the EDID again.

10.1.2. Advanced EDID Management

Each DVI sink (e.g. monitors, projectors, plasma displays, etc...) must support the EDID data structure. Source BIOS and operating systems are likely to query the sink using DDC2B protocol to determine what pixel formats and interface are supported. DVI standard uses EDID data structure to identify the monitor type and capabilities. Most DVI sources (VGA cards, set top boxes, etc.) will output DVI signal after accepting the connected sink's EDID information. In the case of EDID readout failure or missing EDID, the source will not output DVI video signal.

Lightware devices provide the Advanced EDID Management function that helps system integration. The built-in EDID Router can store and emulate factory pre-programmed- and User programmable EDIDs. The EDID of the attached monitors or projectors for each output are stored in a non-volatile memory. This way the EDID of a monitor is available when the monitor is unplugged or switched off.

Any EDID can be emulated on any input. An emulated EDID can be copied from the EDID router's memory (static EDID emulation), or from the last attached monitor's memory (dynamic EDID emulation). For example, the Lightware device can be set up to emulate a sink device, which is connected to one of the outputs. In this case, the EDID automatically changes, if the monitor is replaced with another display device (as long as it has a valid EDID).

EDID is independently programmable for all inputs without affecting each other. All inputs have their own EDID circuit.

INFO: The user is not required to disconnect the video cable to change an EDID as opposed to other manufacturer's products. EDID can be changed even if a source is connected to the input and powered ON.

INFO: When EDID has been changed, the router toggles the HOTPLUG signal for 2 seconds. Some sources do not sense this signal. In such cases, the source device must be restarted or powered OFF and ON again.

10.2. HDCP Management

Lightware Visual Engineering is a legal HDCP adopter. Several functions have been developed which helps to solve HDCP related problems. Complex AV systems often have both HDCP and non-HDCP components. The switcher allows transmitting HDCP encrypted and unencrypted signals. The devices will be still HDCP compliant as they will never output an encrypted signal to a non-HDCP compliant display device. If an encrypted signal is switched to a non-compliant output, a red screen alert or muted screen will appear.

10.2.1. Protected and Unprotected Content

Many video sources send HDCP protected signal if they detect that the sink is HDCP capable – even if the content is not copyrighted. This can cause trouble if an HDCP capable device is connected between the source and the display. In this case, the content cannot be viewed on non-HDCP capable displays and interfaces like event controllers. Rental and staging technicians often complain about certain laptops, which are always sending HDCP encrypted signals if the receiver device (display, matrix router, etc.) reports HDCP compliancy. However, HDCP encryption is not required all the time e.g. computer desktop image, certain laptops still do that.

To avoid unnecessary HDCP encryption, Lightware introduced the HDCP enabling/disabling function: the HDCP capability can be disabled in the Lightware device. If HDCP is disabled, the connected source will detect that the sink is not HDCP capable, and turn off authentication.

10.2.2. Disable Unnecessary Encryption

HDCP Compliant Sink

All the devices are HDCP-compliant, no manual setting is required, both protected and unprotected contents are transmitted and displayed on the sink.



Not HDCP-compliant Sink 1.

Not-HDCP compliant sink is connected to the switcher. Some sources (e.g. computers) always send HDCP encrypted signals if the receiver device reports HDCP compliancy, however, HDCP encryption is not required all the time (e.g. computer desktop image). If HDCP is enabled in the switcher, the image will not be displayed on the sink.



Setting the HDCP parameter to Auto on the output port and disable HDCP on the input port, the transmitted signal will not be encrypted if the content is not protected. Thus, non-HDCP compliant sinks will display non-encrypted signal.

Not HDCP-compliant Sink 2.

The layout is the same as in the previous case: non-HDCP compliant display device is connected to the switcher but the source would send protected content with encryption. If HDCP is enabled on the input port of the switcher, the source will send encrypted signal.



The sink is not HDCP compliant, thus, it will not display the video signal (but blank/red/muted/etc. screen). If HDCP is disabled on the input port of the switcher, the source will not send the signal. The solution is to replace the display device to an HDCP-capable one.

10.2.3. HDCP v2.2

HDCP v2.2 is the latest evolution of copy protection. It is designed to create a secure connection between a source and a display. The 2.x version of HDCP is not a continuation of HDCPv1, and is rather a completely different link protection. One of the main differences is the number of the allowed devices within a closed A/V system: HDCP v2.2 allows 32 devices (HDCP v1.4 allows 128 devices). Further limit is that up to four level is allowed which means the protected signal can be transmitted over at most four repeater/matrix/switcher device. HDCP content protection is activated only if an active video stream is transmitted from the source to the display. The encryption is not activated without a video signal.

HDCP v2.2 standard allows to apply a previous version of HDCP (e.g. HDCP v1.4) between the source and the display if the source device allows it. According to the standard if the image content is protected with HDCP, the highest supported content protection level has to be applied. However, if the highest level of protection is not justified by the source content the level may be decreased to avoid compatibility problems; this case is determined by the source.

HDCP v2.2 Source and HDCP v1.4 Sink

In this case the signal of an HDCP v2.2 compliant source is switched to an HDCP v1.4 compliant sink device. The signal is encrypted with HDCP v2.2 on the input and encrypted with HDCP v1.4 on the output of the Lightware device. A lower level of encryption may be applied only if the source device/content allows it - according to the HDCP standard. In this case the HDCP setting on the input port has to be set to HDCP 1.4 and Depends on input on the output port.



HDCP v1.4 Source and HDCP v2.2 Sink

The below example is the reversal of the previous case. An HDCP v1.4 compliant source sends a signal with HDCP v1.4 encryption. The signal is switched to an HDCP v2.2 compliant sink device. In this case the outgoing signal has to be encrypted with the highest supported encryption level towards the sink, as the Lightware device and the sink are both HDCP v2.2 compliant. The HDCP v2.2 standard does not allow keeping the original HDCP v1.4 encryption level on the output.



What Kind of Signal Will be on the Output of the Lightware Device?

See below table that summarizes the possible cases:

Incoming Signal	HDCP v1.4 Compatible Sink on the Output	HDCP v2.2. Compatible Sink on the Output
HDCP v1.4	HDCP v1.4	HDCP v2.2
HDCP v2.2 (convertable)*	HDCP v1.4	HDCP v2.2
HDCP v2.2 (not convertable)*	Red screen	HDCP v2.2

* Stream type 0: the video stream allows to convert the signal to apply a lower level of encryption.

** Stream type 1: the video stream does not allow to convert the signal.

10.3. Pixel Accurate Reclocking

Signal reclocking is an essential important procedure in digital signal transmission. After passing the reclocking circuit, the signal becomes stable, jitter-free, and can be transmitted over more equipment like processors, or event controllers. Without reclocking, sparkles, noise, and jaggies appear on the image.

Lightware's sophisticated Pixel Accurate Reclocking technology fixes more problems than general TMDS reclocking. It removes not only intra-pair skew but inter-pair skew as well. The Pixel Accurate Reclocking circuit eliminates the following errors:

Intra-pair skew

Skew between the + and - wires within a differential wire pair (e.g. Data2- and Data2+). It's caused by different wire lengths or slightly different wire construction (impedance mismatch) in DVI cable. It results in jitter.

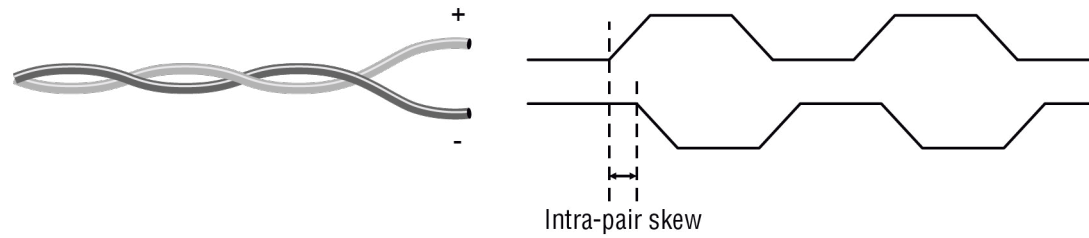

Inter-pair skew

Skew between two differential wire pairs in a cable. It is caused by different wire pair lengths or different number of twists in the DVI cable. Too much inter-pair skew results color shift in the picture or sync loss.

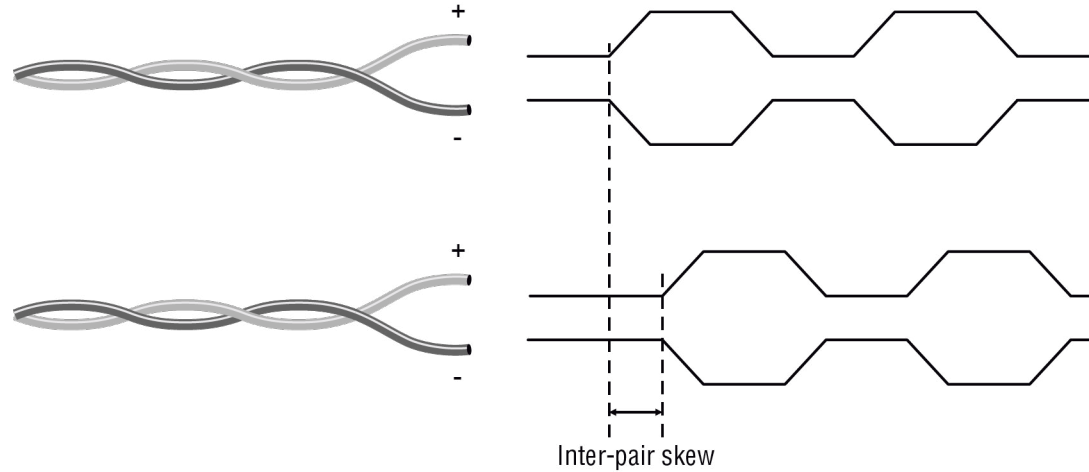

Jitter

Signal instability in the time domain. The time difference between two signal transitions should be a fixed value, but noise and other effects cause variations.

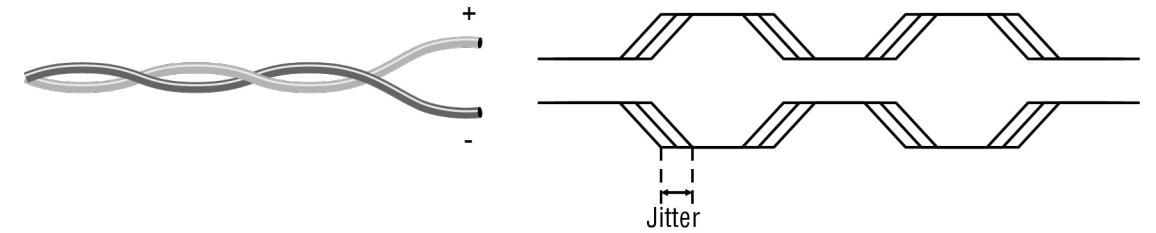

Noise

Electromagnetic interference between other electronic devices such as mobile phones, motors, etc. and the DVI cable are coupled onto the signal. Too much noise results in increased jitter.

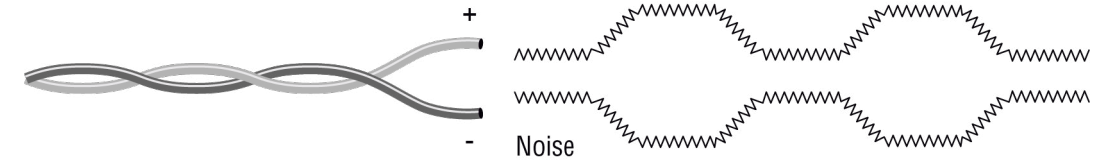

11

Appendix

Tables, drawings, guides, technical details and hashtag keyword list as follows:

- ▶ [SPECIFICATIONS](#)
- ▶ [FACTORY EDID LIST](#)
- ▶ [CABLE WIRING GUIDE](#)
- ▶ [MECHANICAL DRAWINGS](#)
- ▶ [FACTORY DEFAULT SETTINGS](#)
- ▶ [PORT NUMBERING](#)
- ▶ [HASHTAG KEYWORD LIST](#)
- ▶ [FURTHER INFORMATION](#)

11.1. Specifications

General

Compliance	CE
Electrical safety.....	IEC 61000-3-3:2013+AMD1:2017
EMC (emission).....	IEC/EN 55032:2015
EMC (immunity).....	IEC/EN 55035:2017
RoHS.....	EN 63000:2018
Warranty	3 years
Operating temperature	0° to +50°C (+32° to +122°F)
Operating humidity	10% to 90%, non-condensing
Cooling.....	Cooling fan

Power

Power supply option	External 120W Power Supply
Supported power source	100-240 V AC; 50/60 Hz
Power consumption (max).....	120W
Power consumption (min).....	10W
Heat dissipation.....	36 BTU/h (max)
Supplied power	24V DC, 5A
AC power plug.....	Interchangeable (EU, UK, JP/US, AUS/NZ)

Enclosure

Enclosure material	1 mm steel
Dimensions in mm.....	246 W x 140,3 D x 26 H
Dimensions in inch	9.59 W x 5.57 D x 1.01 H
Weight.....	700 g

Video Inputs

USB-C input

Connector type.....	24-pole USB type C receptacle
A/V standard.....	DP 1.2a
HDCP compliance.....	HDCP 1.4, HDCP 2.2
Color space	RGB, YCbCr

Video delay.....	0 frame
Max. video resolution	4096x2160@60Hz RGB 4:4:4 (up to 600MHz pixel clock)
.....	1920x1080@120 Hz, 36 bit
Audio formats	all formats in line with HDMI 2.0 standard
3D support.....	yes

HDMI input

Connector type.....	19-pole HDMI Type A receptacle
.....	(with screw locking option)
A/V standard.....	DVI 1.0, HDMI 1.4, HDMI 2.0
Maximum data rate.....	18Gbps
Maximum pixel clock.....	597MHz
HDCP compliance.....	HDCP 1.4, HDCP 2.2
Color space	RGB, YCbCr
Video delay.....	0 frame
Max. video resolution	4096x2160@60Hz RGB 4:4:4 (up to 600MHz pixel clock)
.....	1920x1080@120 Hz, 36 bit
Max. input HDMI cable length (with premium certified cable) at	
3840x2160@60Hz 4:4:4.....	5m
Reclocking.....	Pixel Accurate Reclocking
3D support.....	yes
Audio mode	
.....	Simultaneous pass-through and de-embedding to the Audio layer
Supported audio formats for pass-through	All HDMI2.0 audio formats
Supported audio formats for de-embedding	Uncompressed
.....	LPCM (up to 8 channels, 192 kHz, 24 bits per sample)
Compressed.....	Dolby Digital, DTS
.....	Compressed HBR
.....	Dolby TrueHD, DTS-HD

Video Outputs

HDMI output

Connector type.....	19-pole HDMI Type A receptacle
A/V standard.....	DVI 1.0, HDMI 1.4, HDMI 2.0
HDCP compliance.....	HDCP 1.4, HDCP 2.2
Color space	RGB, YCbCr
Supported resolutions at 8 bits/color *	
.....	up to 4096x2048@30Hz (4:4:4) or 4096x2048@60Hz (4:2:0)
.....	up to 3840x2160@30Hz (4:4:4) or 3840x2160@60Hz (4:2:0)
.....	1920x1080@60Hz (4:4:4) up to 12 bits/color
Audio formats	8 channel PCM, Dolby TrueHD
.....	DTS-HD Master Audio 7.1

* All standard VESA and CEA resolutions up to 300MHz (HDMI1.4) and other custom resolutions up to 300Mhz are supported.

Audio Ports

Analog audio output

Connector type.....	5-pole Phoenix connector
Audio formats	2-ch PCM
Sampling frequency	48 kHz
Volume.....	-95.62 dB - 0 dB
Balance.....	-100 - +100 (0 = center)

Dante® Audio Output Port *#new*

Connector type.....	RJ45 female connector
Signal transmission	Dante® or AES67
Supported channels.....	2-channel stereo
Sampling rates	44.1, 48, 88,2, 96 kHz

Control Ports

Ethernet port

Connector type.....	RJ45 female connector
Ethernet data rate	10/100Base-T, full duplex with autodetect
Power over Ethernet (PoE)	Not supported

GPIO port #new

Connector type..... 8-pole Phoenix
 Function (pin 1-6)..... Configurable (input/output)
 Function (pin 7)..... 5V output
 Function (pin 8)..... Ground

OCS port #new

Connector type..... 3-pole Reversed Gender Plug Phoenix connector
 Number of configurable pins 1
 Port direction..... Input

USB port

Connector type..... C-type receptacle
 USB compliance..... USB 3.1 Gen1
 Connector type..... A-type receptacle
 USB compliance..... USB 2.0, USB 3.1 Gen1
 Connector type..... B-type receptacle
 USB compliance..... USB 3.0
 Connector type..... mini-B type
 USB compliance..... USB 2.0

11.2. Port Numbering

Audio/Video Ports

Port name		Video port nr. (LW3)	Audio port nr. (LW3)
Inputs	USB-C in 1	I1	I1
	USB-C in 2	I2	I2
	HDMI in 3	I3	I3
	HDMI in 4	I4	I4
	Welcome Screen	I5	-
Outputs	HDMI out 1	O1	O1
	HDMI out 2	O2	O2
	Analog audio out	-	O3

USB Ports

Port name		USB port nr. (LW3)
Upstream Facing Ports	USB-C Host 1	U1
	USB-C Host 2	U2
	USB-B Host 3	U3
	USB-B Host 4	U4
USB Hub/ Downstream Port	USB hub	H1
	USB Device 1	D1
	USB Device 2	D2
	USB Device 3	D3
	USB Device 4	D4

Ethernet Ports

Port name	USB port nr. (LW3)
Secure Eth 1	P1
Utility Eth 2	P2
Utility Eth 3	P3
USB-C in1 (Eth)	P4
USB-C in2 (Eth)	P5

11.3. Factory EDID List

Mem.	Resolution			Type
F1	640 x	480	@ 60.00 Hz	D
F2	848 x	480	@ 60.00 Hz	D
F3	800 x	600	@ 60.32 Hz	D
F4	1024 x	768	@ 60.00 Hz	D
F5	1280 x	768	@ 50.00 Hz	D
F6	1280 x	768	@ 59.94 Hz	D
F7	1280 x	768	@ 75.00 Hz	D
F8	1360 x	768	@ 60.02 Hz	D
F9	1280 x	1024	@ 50.00 Hz	D
F10	1280 x	1024	@ 60.02 Hz	D
F11	1280 x	1024	@ 75.02 Hz	D
F12	1400 x	1050	@ 50.00 Hz	D
F13	1400 x	1050	@ 60.00 Hz	D
F14	1400 x	1050	@ 75.00 Hz	D
F15	1680 x	1050	@ 60.00 Hz	D
F16	1920 x	1080	@ 50.00 Hz	D
F17	1920 x	1080	@ 60.00 Hz	D
F18	2048 x	1080	@ 50.00 Hz	D
F19	2048 x	1080	@ 60.00 Hz	D
F20	1600 x	1200	@ 50.00 Hz	D
F21	1600 x	1200	@ 60.00 Hz	D
F22	1920 x	1200	@ 50.00 Hz	D
F23	1920 x	1200	@ 59.56 Hz	D
F24	2048 x	1200	@ 59.96 Hz	D
F29	Universal DVI			
F30	1440 x	480	@ 60.05 Hz	H
F31	1440 x	576	@ 50.08 Hz	H
F32	640 x	480	@ 59.95 Hz	H
F33	720 x	480	@ 59.94 Hz	H
F34	720 x	576	@ 50.00 Hz	H

Mem.	Resolution			Type
F35	1280 x	720	@ 50.00 Hz	H
F36	1280 x	720	@ 60.00 Hz	H
F37	1920 x	1080	@ 50.04 Hz	H
F38	1920 x	1080	@ 50.00 Hz	H
F39	1920 x	1080	@ 60.05 Hz	H
F40	1920 x	1080	@ 60.05 Hz	H
F41	1920 x	1080	@ 24.00 Hz	H
F42	1920 x	1080	@ 25.00 Hz	H
F43	1920 x	1080	@ 30.00 Hz	H
F44	1920 x	1080	@ 50.00 Hz	H
F45	1920 x	1080	@ 60.00 Hz	H
F46	1920 x	1080	@ 60.00 Hz	H
F47	Universal HDMI with PCM audio			
F48	Universal HDMI with All audio			
F49	Universal HDMI, all audio, deep color			
F91	1024 x	2400	@ 60.01 Hz	H
F98	1280 x	720	@ 60.00 Hz	H
F99	1920 x	1080	@ 60.00 Hz	H
F100	1024 x	768	@ 60.00 Hz	H
F101	1280 x	1024	@ 50.00 Hz	H
F102	1280 x	1024	@ 60.02 Hz	H
F103	1280 x	1024	@ 75.02 Hz	H
F104	1600 x	1200	@ 50.00 Hz	H
F105	1600 x	1200	@ 60.00 Hz	H
F106	1920 x	1200	@ 59.56 Hz	H
F107	2560 x	1440	@ 59.95 Hz	H
F108	2560 x	1600	@ 59.86 Hz	H
F109	3840 x	2400	@ 24.00 Hz	H
F110	3840 x	2160	@ 24.00 Hz	H
F111	3840 x	2160	@ 25.00 Hz	H

Mem.	Resolution			Type
F112	3840 x	2160	@ 30.00 Hz	H
F118	Universal HDMI, 4K, PCM audio			
F119	Universal HDMI, 4K, all audio			
F120	3840 x	2160	@ 60.00 Hz	H
F121	1440 x	1080	@ 59.91 Hz	H
F122	2560 x	2048	@ 59.98 Hz	H
F123	1280 x	800	@ 59.91 Hz	H
F124	1440 x	900	@ 59.90 Hz	H
F125	1366 x	768	@ 60.00 Hz	H
F126	1600 x	900	@ 59.98 Hz	H
F127	2048 x	1080	@ 60.00 Hz	H
F128	2560 x	1080	@ 60.00 Hz	H
F129	3440 x	1440	@ 24.99 Hz	H
F130	3440 x	1440	@ 29.99 Hz	H
F131	4096 x	2160	@ 25.00 Hz	H
F132	4096 x	2160	@ 30.00 Hz	H
F133	4096 x	2160	@ 60.00 Hz	4:2:0
F134	3440 x	1440	@ 23.99 Hz	H
F135	4096 x	2160	@ 24.00 Hz	H
F136	3840 x	2400	@ 29.99 Hz	H
F137	3840 x	2160	@ 60.00 Hz	H2
F138	3840 x	2160	@ 50.00 Hz	H2
F139	Universal HDMI 2.0, UHD, PCM audio			
F140	Universal HDMI 2.0, UHD, all audio			
F141	4096 x	2160	@ 60.00 Hz	4:4:4
F142	4096 x	2160	@ 50.00 Hz	4:4:4
F143	Universal HDMI 2.0, 4K, PCM audio			
F144	Universal HDMI 2.0, 4K, all audio			
F146	3840 x	2160	@ 60.00 Hz	HDR
F147	3840 x	2160	@ 60.00 Hz	RB, PCM

Mem.	Resolution			Type
F148	3840 x	2160	@ 60.00 Hz	RB, ALL

U: Universal EDID, supporting many standard resolutions:

- F29: Universal EDID for DVI signals (no audio support).
- F47: HDMI EDID supporting PCM audio.
- F48: HDMI EDID supporting all type of audio.
- F49: HDMI EDID supporting all type of audio and deep color.
- F89: Universal EDID for analog signals (no audio support).
- F118: HDMI EDID supporting PCM audio and 4K@30 Hz signals.
- F119: HDMI EDID supporting all type of audio and 4K@30 Hz signals.

Please note that minor changes in the factory EDID list may be applied in farther firmware versions.

11.4. Cable Wiring Guide

Inputs and outputs of audio devices are symmetric or asymmetric. The main advantage of the symmetric lines is the better protection against the noise therefore, they are widely used in the professional audio industry. Symmetric audio is most often referred to as balanced audio, as opposed to asymmetric, which is referred to as unbalanced audio. Lightware products are usually built with 5-pole Phoenix connectors so we would like to help users assembling their own audio cables. See the most common cases below.

ATTENTION! Symmetric and asymmetric lines can be linked with passive accessories (e.g. special cables), but in this case half of the line level is lost.

ATTENTION! There are numerous types of regularly used connector and cable types to connect audio devices. Please always make sure that a connector or cable fits your system before use.

ATTENTION! Never join the phase-inverted (negative, cold or -) poles (either right and left) to the ground or to each other on the output side, as this can damage the unit.

INFO: Use a galvanic isolation in case of a ground loop.

11.4.1. Audio Ports

The Pinout of the 5-pole Phoenix Connector

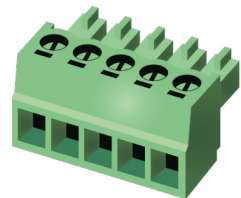

Pin nr.	Signal
1	Left+
2	Left-
3	Ground
4	Right-
5	Right+

Compatible Plug Type: Phoenix® Combicon series (3.5mm pitch, 5-pole), type: MC 1.5/5-ST-3.5.

From Balanced Output to Unbalanced Input

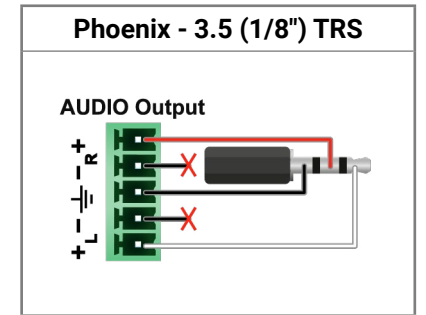
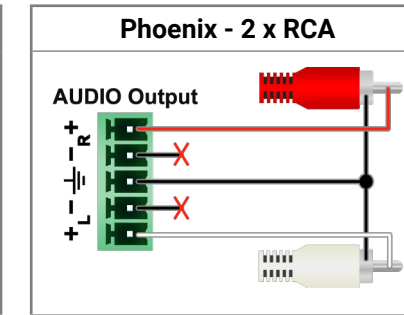
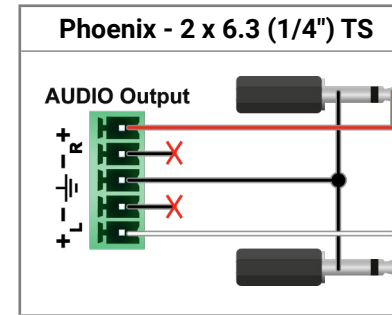

From Balanced Output to Balanced Input

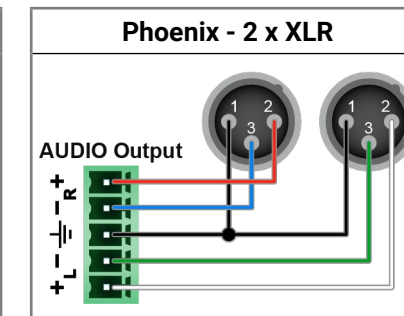
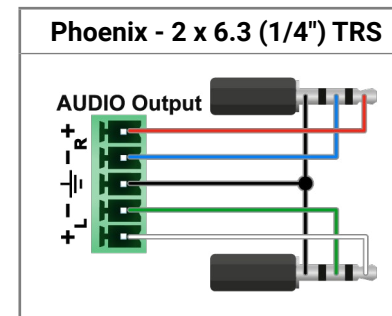

11.5. Mechanical Drawings

Dimensions are in mm.

UCX-4x2-HC30 model

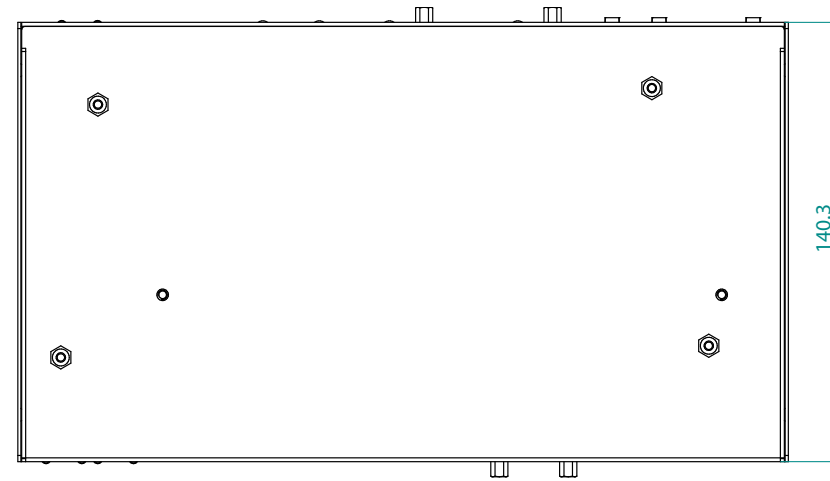

Power supply

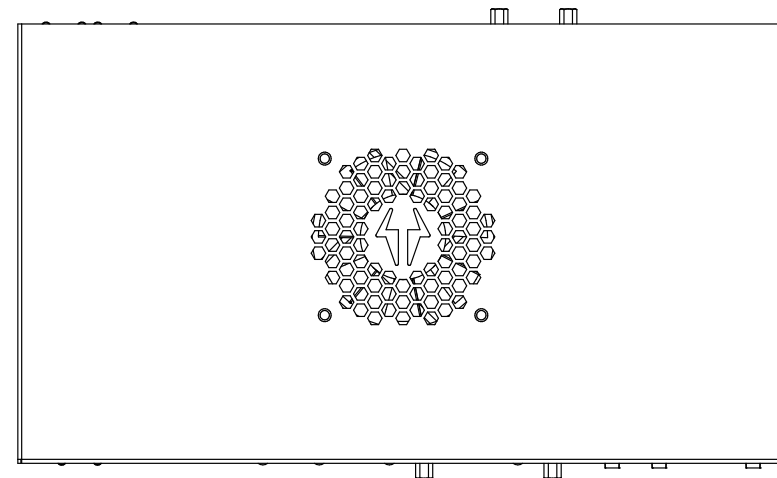
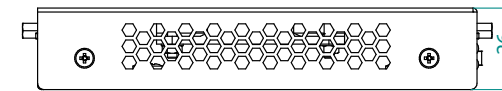
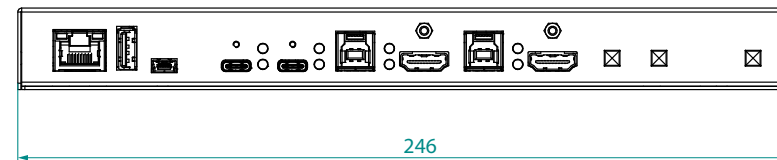
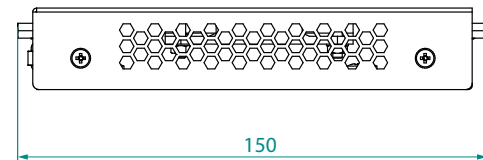
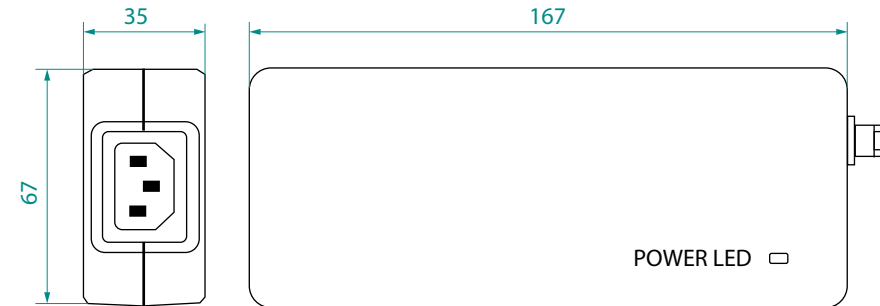

UCX-4x2-HC30D model

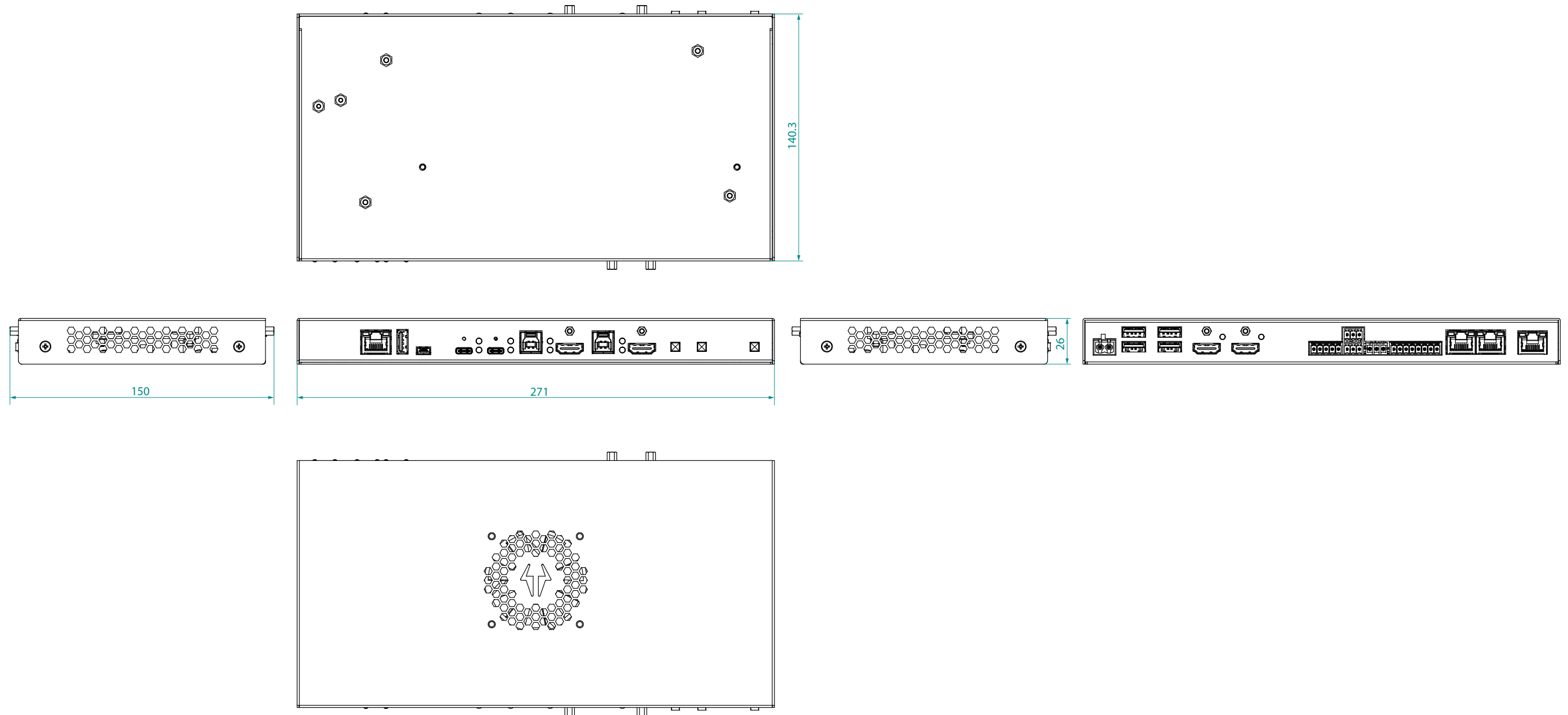

11.6. Factory Default Settings

Parameter	Setting/Value
Network settings	
Factory default IP	DHCP
Video crosspoint settings	
O1 (HDMI out 1)	I1
O2 (HDMI out 2)	I3
Audio crosspoint settings	
O3 (Analog out)	I1
USB crosspoint settings	
H1 (USB hub)	U1 (USB-C Host 1)
Video port settings	
Display Welcome Screen Image	true
Display Welcome Screen Message	false
Allowed HDCP Version	I1, I2: HDCP 1.4; I3,I4: HDCP 2.2
DP Alternate Mode Policy	Auto
Autoselect operation policy	Disable autoselect
Signal type	Auto
HDCP mode	Auto
Power 5V Enable	On
Emulated EDID on all four inputs	Factory #47: Universal HDMI PCM
Analog audio output port settings	
Volume	0.00 dB (100%)
Balance	0 (center)
Autoselect	Follow video O1
USB port settings	
USB-C Power Limit	Equal output power
DP Alternate Mode Policy	Auto
Port Power Role	Dual Role
Autoselect	Follow video O1
D1-D4 Power 5V Mode	Auto
GPIO port settings	
Output level	High
Direction	Input

Occupancy sensor	
Sensor type	Active high
Miscellaneous	
Unique port names	Cleared
Unique device label	Cleared
User EDIDs	Cleared

11.7. Applied Ports (Network Settings)

The following ports are necessary to pass via a network switch/ firewall for a proper working between the device and the softwares:

Purpose/function	Protocol	Port nr.
Firmware upgrade TFTP	UDP	69
	UDP	49990
	UDP	49995
Device Discovery	UDP	224.0.0.251:5353
Remote IP	UDP	230.76.87.82:37421

11.8. Firmware Release Notes

Below list shows the released firmware packages with important notes

v1.1.0b7

Release date: 2021-03-04

New feature:

- Welcome Screen, OCS and GPIO properties now available in LW3
- Autoselect functionalities added to USB layer
- UCX-4x2-HC30D variant is supported
- Configuration cloning
- New port properties

Bugfix:

- The following properties can be set to On or Off mode: /V1/MEDIA/VIDEO/O1.Output5VMode /V1/MEDIA/VIDEO/O2.Output5VMode Auto mode will be available in a future release.
- Ethernet port P5 is counting TX Ethernet packets even if there is no connection. /MEDIA/ETHERNET/P5/COUNTERS.TxCounter Ethernet packet transmission on P5 is not affected by this issue. This Ethernet port works as expected other than the incorrect TX counter value.
- If a USB Host without DisplayPort Alterante mode support is connected to one of the USB Type-C connectors, then the ActiveAltMode property erroneously reads as DP. /V1/MEDIA/USB/U1.ActiveAltMode=DP This issue causes Lightware Device Controller to erroneously display a yellow "DP" indicator on the port panel, which means the connection successfully entered DisplayPort Alterante mode. The following property describing the DisplayPort Alterante mode capability of the connected Host works as expected. /V1/MEDIA/USB/U1.HostSupportsDpAltMode=false USB and Displayport Data transmission is not affected.
- An external control system using LW3 protocol subscribed to an HDMI output node OPEN /V1/MEDIA/VIDEO/O1 might not receive all CHG messages related to the presence of embedded audio on the output. For example if the video crosspoint switches between two sources: one with- and one without embedded audio, then the following CHG messages might be missing: CHG /V1/MEDIA/VIDEO/O1.EmbeddedAudioPresent=false CHG /V1/MEDIA/VIDEO/O1.EmbeddedAudioPresent=true Transmission of the embedded audio stream from input to output is unaffected. Muting the audio also works as expected.
- No fading at the analog audio output during signal switching
- VCONN is not supplied by USB Type-C interface of the product, if the port partner sends a Vconn Swap command via Power Delivery Protocol over the Communication Channel. USB Type-C active cables or VCONN powered peripherals require VCONN. These cables or peripherals won't work in the above case. Also communicating with e-Markers of cables will not be possible. Charging, USB and DisplayPort functions using passive cables is not affected. The product has a strong preference toward becoming a Power Source upon connecting a device. The product will source VBUS and VCONN most of the times, therefore Vconn Swap command would only result in the connected device sourcing the Vconn, and avoiding this issue.
- Properties in /SYS node may change in future releases.
- HPD signal is activated with up to 100ms delay compared to the 5V signal. This might cause compatibility issue with some devices.

- If I1 input is selected by Autoselect after I5 input, the value of the following property might become invalid: /MEDIA/VIDEO/I1/HDCP.ActiveHdcpVersion The video transmission is not affected, only the displayed value of HDCP version is compromised.
- Reporting the presence of embedded audio on the HDMI output is not reliable./MEDIA/VIDEO/O1.EmbeddedAudioPresent The property might read true while there is no embedded audio on the connected input port. Transmission of the embedded audio stream from input to output is unaffected. Muting the audio also works as expected.
- Known issue:
- Properties of Audio XP do not reflect the limitations of the video XP. If I5 is in use on the video layer, neither the video nor the audio content of I1 cannot be used.
- Locked audio or video ports can be muted or unmuted.
- 192kHz multichannel audio is only delivered as stereo to the outputs. Lower sampling rates are not affected.
- SwitchAll method cannot be used to disconnect all outputs. Switch method can be used instead. switchAll(0) method does not work. switch(0:01;0:02) works as expected.

Known issue:

- No fading at the analog audio output during signal switching

v1.0.1b1

Release date: 2020-12-09

Bugfix:

- Improved ZIP file upload

v1.0.0b6

Release date: 2020-11-19

Known issue:

- No fading at the analog audio output during signal switching
- The following properties can be set to On or Off mode: /V1/MEDIA/VIDEO/O1.Output5VMode /V1/MEDIA/VIDEO/O2.Output5VMode Auto mode will be available in a future release.
- Reporting the presence of embedded audio on the HDMI output is not reliable./MEDIA/VIDEO/O1.EmbeddedAudioPresent The property might read true while there is no embedded audio on the connected input port. Transmission of the embedded audio stream from input to output is unaffected. Muting the audio also works as expected.
- VCONN is not supplied by USB Type-C interface of the product, if the port partner sends a Vconn Swap command via Power Delivery Protocol over the Communication Channel. USB Type-C active cables or VCONN powered peripherals require VCONN. These cables or peripherals won't work in the above case. Also communicating with e-Markers of cables will not be possible. Charging, USB and DisplayPort functions using passive cables is not affected. The product has a strong preference toward becoming a Power Source upon connecting a device. The product will source VBUS and VCONN most of the times, therefore Vconn Swap command would only result in the connected device sourcing the Vconn, and avoiding this issue.
- Properties in /SYS node may change in future releases.

- HPD signal is activated with up to 100ms delay compared to the 5V signal. This might cause compatibility issue with some devices.
- If I1 input is selected by Autoselect after I5 input, the value of the following property might become invalid: /MEDIA/VIDEO/I1/HDCP.ActiveHdcpVersion The video transmission is not affected, only the displayed value of HDCP version is compromised.
- Properties of Audio XP do not reflect the limitations of the video XP. If I5 is in use on the video layer, neither the video nor the audio content of I1 cannot be used.
- Ethernet port P5 is counting TX Ethernet packets even if there is no connection. /MEDIA/ETHERNET/P5/COUNTERS.TxCounter Ethernet packet transmission on P5 is not affected by this issue. This Ethernet port works as expected other than the incorrect TX counter value.
- If a USB Host without DisplayPort Alterante mode support is connected to one of the USB Type-C connectors, then the ActiveAltMode property erroneously reads as DP. /V1/MEDIA/USB/U1.ActiveAltMode=DP This issue causes Lightware Device Controller to erroneously display a yellow "DP" indicator on the port panel, which means the connection successfully entered DisplayPort Alterante mode. The following property describing the DisplayPort Alterante mode capability of the connected Host works as expected. /V1/MEDIA/USB/U1.HostSupportsDpAltMode=false USB and Displayport Data transmission is not affected.
- An external control system using LW3 protocol subscribed to an HDMI output node OPEN /V1/MEDIA/VIDEO/O1 might not receive all CHG messages related to the presence of embedded audio on the output. For example if the video crosspoint switches beteen two sources: one with- and one without embedded audio, then the following CHG messages might be missing: CHG /V1/MEDIA/VIDEO/O1.EmbeddedAudioPresent=false CHG /V1/MEDIA/VIDEO/O1.EmbeddedAudioPresent=true Transmission of the embedded audio stream from input to output is unaffected. Muting the audio also works as expected.
- 192kHz multichannel audio is only delivered as stereo to the outputs. Lower sampling rates are not affected.

11.9. Hashtag Keyword List

This user's manual contains keywords with hashtag (#) to help you to find the relevant information as quick as possible.

The format of the keywords is the following:

#<keyword>

The usage of the keywords: use the **Search** function (Ctrl+F / Cmd+F) of your PDF reader application, type the # (hashtag) character and the wished keyword.

The special keyword indicates a new feature/function that has just appeared in the latest firmware or software version.

Example

#dhcp

This keyword is placed at the DHCP (dynamic IP address) setting in the front panel operation, the Lightware Device Controller (LDC) and the LW3 programmer's reference section.

The following list contains all hashtag keywords placed in the document with a short description belonging to them. The list is in **alphabetical order** by the hashtag keywords.

Hashtag Keyword ↓↑	Description
<i>#advancedview</i>	Advanced view / Terminal window
<i>#analogaudio</i>	Analog audio related settings
<i>#autoselect</i>	Autoselect feature settings
<i>#balance</i>	Balance (for analog audio) setting
<i>#buttonlock</i>	Front panel button lock setting
<i>#cablediagnostics</i>	Cable diagnostics tool in LDC
<i>#crosspoint</i>	Crosspoint switch setting
<i>#devicelabel</i>	Device label
<i>#dhcp</i>	Dynamic IP address (DHCP) setting
<i>#diagnostic</i>	Failure diagnostic related tool/information
<i>#dpaltmode</i>	Displayport Alternate mode settings
<i>#alternatemode</i>	Displayport Alternate mode settings
<i>#displayportalternatemode</i>	Displayport Alternate mode settings
<i>#edid</i>	EDID related settings
<i>#factory</i>	Factory default settings
<i>#firmwareversion</i>	Firmware version query
<i>#framedetector</i>	Frame detector in LDC
<i>#gpio</i>	GPIO related settings
<i>#hdc</i>	HDCP-encryption related setting

Hashtag Keyword ↓↑	Description
<i>#ipaddress</i>	IP address related settings
<i>#label</i>	Device label
<i>#lock</i>	Port lock setting
<i>#lockbutton</i>	Front panel button lock setting
<i>#log</i>	System log
<i>#mute</i>	Port mute setting
<i>#network</i>	Network (IP address) related settings
<i>#portstatus</i>	Source/destination port status query
<i>#producttype</i>	Product type query
<i>#power</i>	Power sending settings
<i>#reboot</i>	Restarting the device
<i>#restart</i>	Restarting the device
<i>#serialnumber</i>	Serial number query
<i>#signaltype</i>	HDMI/DVI signal type setting
<i>#status</i>	Status query
<i>#switch</i>	Crosspoint switch setting
<i>#systemlog</i>	System log
<i>#terminal</i>	Advanced view / Terminal window
<i>#testpattern</i>	Test pattern (no sync screen) settings
<i>#ocs</i>	OCS related settings
<i>#unlock</i>	Port unlock setting
<i>#unmute</i>	Port unmute setting
<i>#usb</i>	USB 2.0 interface-related settings
<i>#usbc</i>	USB-C interface-related settings
<i>#volume</i>	Volume (for analog audio) setting
<i>#welcomescreen</i>	Welcome screen settings

11.10. Further Information

Limited Warranty Statement

1. Lightware Visual Engineering LLC (Lightware) warrants to all trade and end user customers that any Lightware product purchased will be free from manufacturing defects in both material and workmanship for three (3) years from purchase unless stated otherwise below. The warranty period will begin on the latest possible date where proof of purchase/delivery can be provided by the customer. In the event that no proof can be provided (empty 'Date of purchase' field or a copy of invoice), the warranty period will begin from the point of delivery from Lightware.

1.1. 25G and MODEX product series will be subject to a seven (7) year warranty period under the same terms as outlined in this document.

1.2. If during the first three (3) months of purchase, the customer is unhappy with any aspect of a Lightware product, Lightware will accept a return for full credit.

1.3. Any product that fails in the first six (6) months of the warranty period will automatically be eligible for replacement and advanced replacement where available. Any replacements provided will be warranted for the remainder of the original unit's warranty period.

1.4. Product failures from six (6) months to the end of the warranty period will either be repaired or replaced at the discretion of Lightware. If Lightware chooses to replace the product then the replacement will be warranted for the remainder of the original unit's warranty period.

2. The above-stated warranty and procedures will not apply to any product that has been:

2.1. Modified, repaired or altered by anyone other than a certified Lightware engineer unless expressly agreed beforehand.

2.2. Used in any application other than that for which it was intended.

2.3. Subjected to any mechanical or electrical abuse or accidental damage.

2.4. Any costs incurred for repair/replacement of goods that fall into the above categories (2.1., 2.2., 2.3.) will be borne by the customer at a pre-agreed figure.

3. All products to be returned to Lightware require a return material authorization number (RMA) prior to shipment and this number must be clearly marked on the box. If an RMA number is not obtained or is not clearly marked on the box, Lightware will refuse the shipment.

3.1. The customer will be responsible for in-bound and Lightware will be responsible for out-bound shipping costs.

3.2. Newly repaired or replaced products will be warranted to the end of the originally purchased products warranty period.

Document Revision History

Rev.	Release date	Changes	Editor
1.0	19.11.2020	Initial version	Judit Barsony
1.1	25.11.2020	Minor corrections, add firmware upgrade chapter	Judit Barsony
1.2	21.12.2020	LED description modifying, add script management section to LDC chapter, complete troubleshooting chapter, add examples to autoselect description, add hashtags	Judit Barsony
1.3	05.03.2021	Add UCX-4x2-HC30D model info, add OCS and GPIO descriptions, LW3 progref extended; update screenshots in LDC chapter	Judit Barsony
1.4	04.05.2021	Correct factory default restore description	Judit Barsony

Contact Us

sales@lightware.com

+36 1 255 3800

support@lightware.com

+36 1 255 3810

Lightware Visual Engineering LLC.
Peterdy 15, Budapest H-1071, Hungary

www.lightware.com

visual engineering
LIGHTWARE

